



# Teaching Finite Elements Using the Kolb Learning Cycle

**Prof. Ashland O. Brown**

School of Engineering and Computer Science

MSC Software Virtual Product Development Conference

Huntington Beach, California October 18-20, 2004



## Outline of Presentation

Abstract

Introduction and Background

Goals and Objectives

Example of using the Kolb Learning Cycle

MSC.Nastran Tutorials

Student Assessment of Tutorials

Example of Student Projects

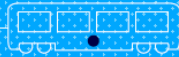

# Abstract

The Kolb model describes an entire learning cycle where students are provided four learning experiences as is shown in Figure 1

Finite Element (FE) method is a numerical procedure used to analyze engineering problems

The Kolb model of learning has been used for the past three years at Pacific to instruct undergraduates in an introductory course of FE

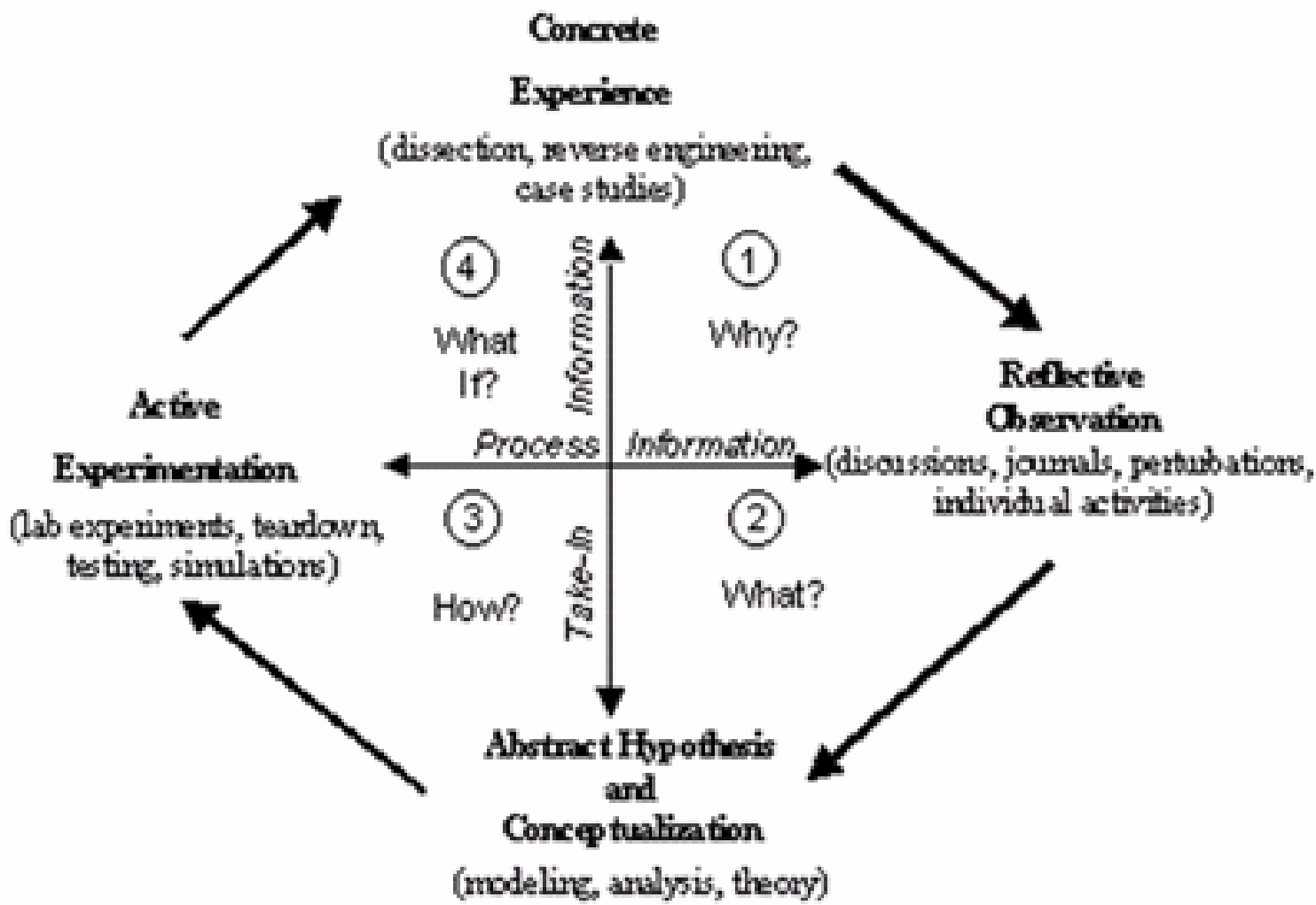
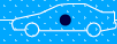

**FIGURE 1: Kolb Cycle**



# Introduction and Background

Teaching of FE historically resided in Graduate Programs

Today FE method is widely used in Industry

The FE method has been used to reduce product design time and costs

We currently teach FE as an elective in ME/CE

Future Plans are to offer FE modules for required courses in all engineering curricula

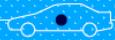

# Goals and Objectives

## Course Learning objectives

- Instruct students in mathematical theory of FE
- Formulation and solving engineering problems using Analytical formulation of FE method
- Instruction of various finite element topologies
- Instruction in using MSC.Nastran to model and analyze structures and thermal problems
- Instruction in error analysis of FE models using experimental test data

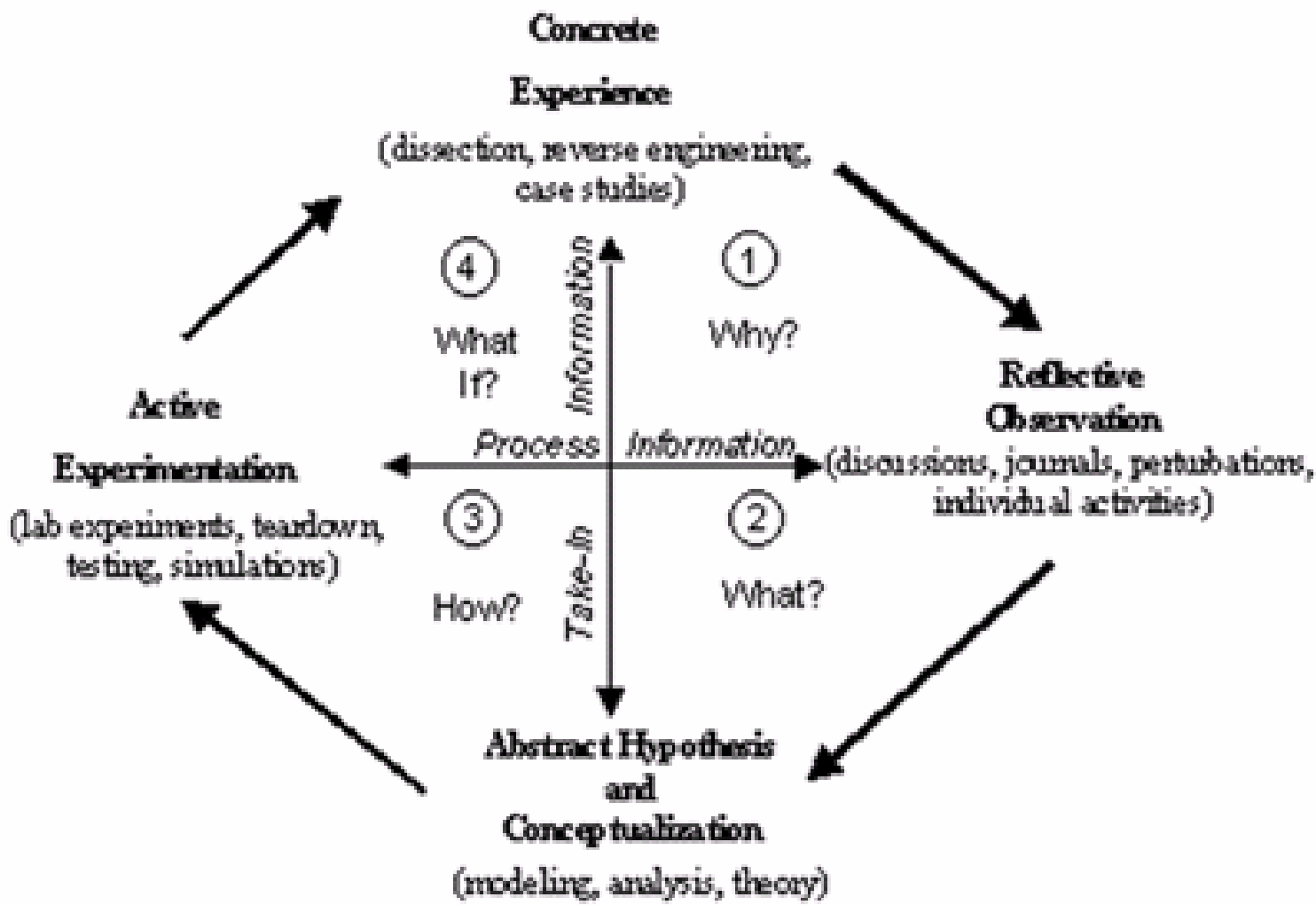
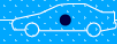

**FIGURE 1: Kolb Cycle**



# Teaching FE using the Kolb Learning Cycle

Introduction of Basic Direct Stiffness-Analysis Method for Trusses

( *Abstract Hypothesis - Conceptualization* )

Build a Truss Problem using MSC.Nastran Tutorial  
( *Concrete Experience* with software model )

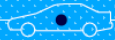

# Teaching FE using the Kolb Learning Cycle

Run the Truss Example Problem in the computer  
(***Active Experimentation-simulations***)

Respond to Questions at the end of Tutorial Exercise  
(***Reflective Observation***)



# Teaching FE using the Kolb Learning Cycle (Abstract Conceptual Topics)

- Review of matrix math, solution of linear simultaneous equations
- Stiffness Matrices, Springs and Bar Elements
- Truss Structures: The Direct Stiffness Method
- Mathematic Basics of FE (Min Pot Energy, Nodal Loads, Singularity, Weighted Residual Method, Shape Functions)
- Topology of FE ( 1D, 2D, 3D Elements and their uses )



# MSC.Nastran FE Tutorials

| <u>MSC Tutorial</u> | <u>Concepts</u>  | <u>Engr. Problem</u> |
|---------------------|------------------|----------------------|
| 1. 1-D Element      | Spar Theory      | Bar                  |
| 2. 1-D Element      | Truss Theory     | Truss                |
| 3. 2-D Element      | 2D Spar Theory   | Frame                |
| 4. 3-D Element      | 3D Solid         | Bearing Fix          |
| 5. 3-D Element      | 3D Solid with HT | Cooling fin          |

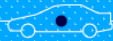

# WORKSHOP 1

## Bar

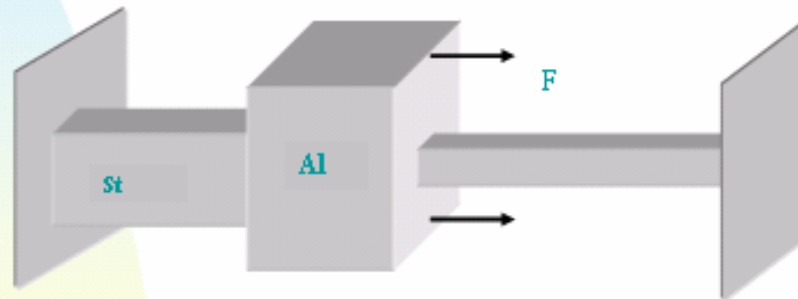

WS1-1

MSC SOFTWARE  
VIRTUAL REALITY

## ■ Table of Contents

- ◆ Background Information
  - ◆ General
  - ◆ Finite Element Theory
- ◆ Problem Description
  - ◆ Model Definition
  - ◆ Educational Objectives
  - ◆ Analysis Objectives
  - ◆ Assumptions
  - ◆ Expectations and/or Analytical Comparison
- ◆ Suggested Steps
- ◆ Step by Step Process
  - ◆ Create New Database
  - ◆ Geometry
  - ◆ Finite Elements
  - ◆ Loads / BCs
  - ◆ Materials
  - ◆ Properties
  - ◆ Analysis
  - ◆ Results
- ◆ Summary

## ■ Problem Description

### ◆ Expectations

The analytic solution for stresses and displacements for this problem is readily available. Any Mechanics of Materials text will provide equations for the displacements and stresses throughout the bar. The problem is indeterminate because there are two reactions (one at each wall) and only one relevant equilibrium equation ( $\sum F_x = 0$ ). Therefore, it is necessary to use the Mechanics of materials (stress and or displacement) equations as well as the force equilibrium equations to solve the problem.

The normal stress due to axial loading is given by:  $\sigma = \frac{PL}{AE}$ , where P is the internal force in the axial direction and A is the cross sectional area of the bar. The displacements are computed from  $\delta = \frac{PL}{EA}$  here L is the bar's length and E is the Elastic (Young's) modulus.

Some basic questions to consider before creating the computational model are:

- Where will the stresses be tensile and where will they be compressive?
- What will be the magnitude and direction of the reaction forces?
- Where will the displacements be greatest?
- How do the displacements vary along the length (linear, quadratic etc.)?
- What will the local effect of the concentrated load be on the stresses?
- Is the model fully constrained from rigid body rotations and displacements?

Answering these questions qualitatively, along with the quantitative analytical solutions for the stresses and displacements, will provide reinforcement that your computational model is correctly constructed.

# CREATE NEW DATABASE

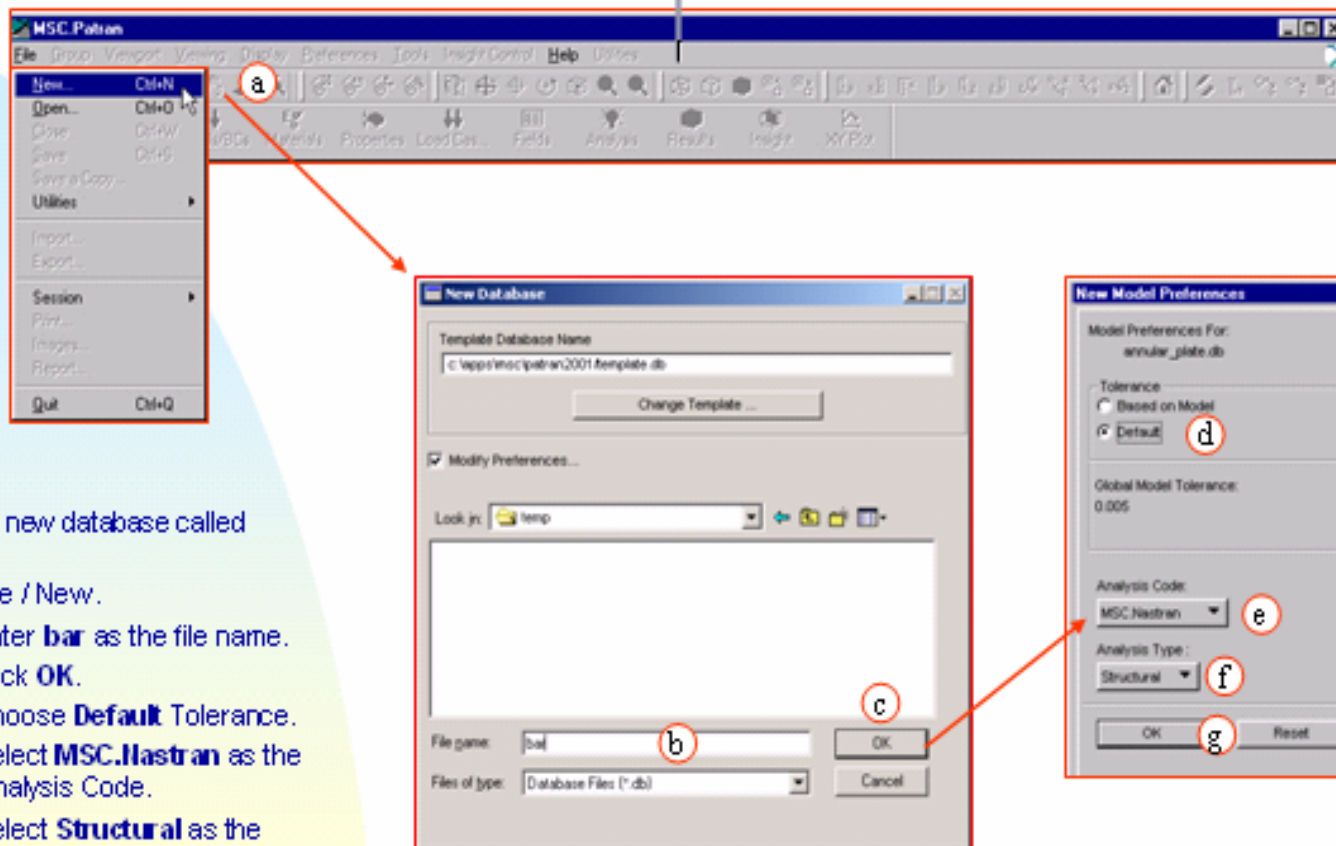

Create a new database called bar.db.

- a. File / New.
- b. Enter **bar** as the file name.
- c. Click **OK**.
- d. Choose **Default** Tolerance.
- e. Select **MSC.Nastran** as the Analysis Code.
- f. Select **Structural** as the Analysis Type.
- g. Click **OK**.

## Step 7. Results: Create / Marker / Vector

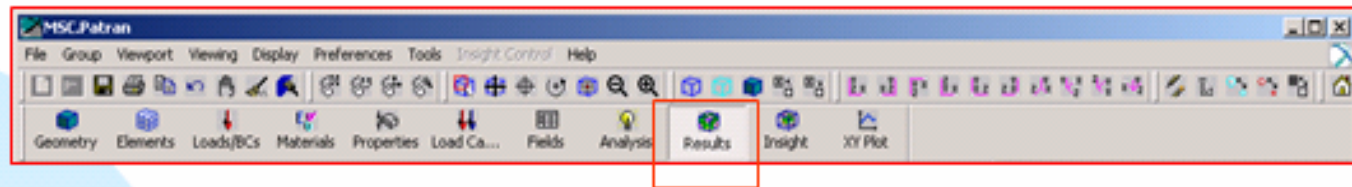

Plotting results (Reaction Forces)

- Results: Create / Marker / Vector
- Select Results Cases: Default, Static Sub case
- Select Vector Result: Constraint Forces, Transnational
- Shown As: Resultant
- Apply

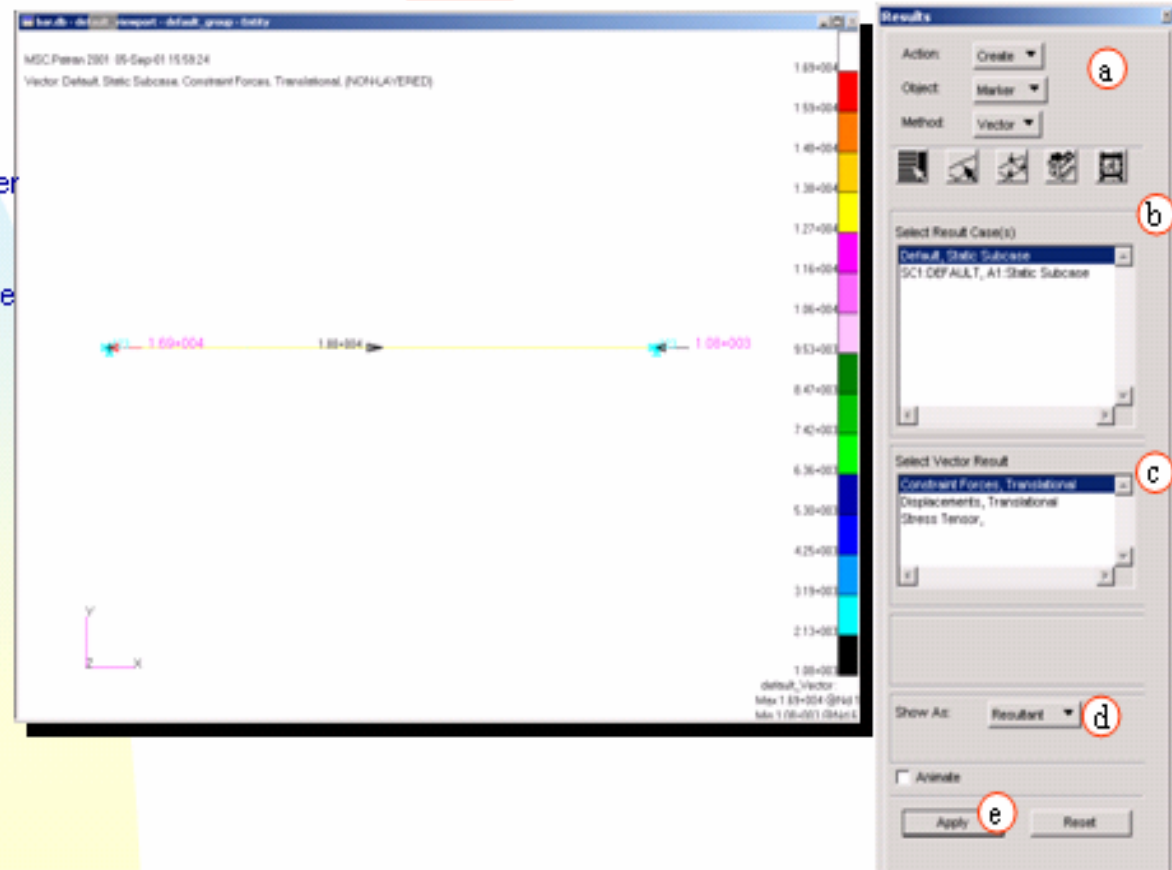

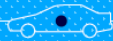

# WORKSHOP 2

## Truss

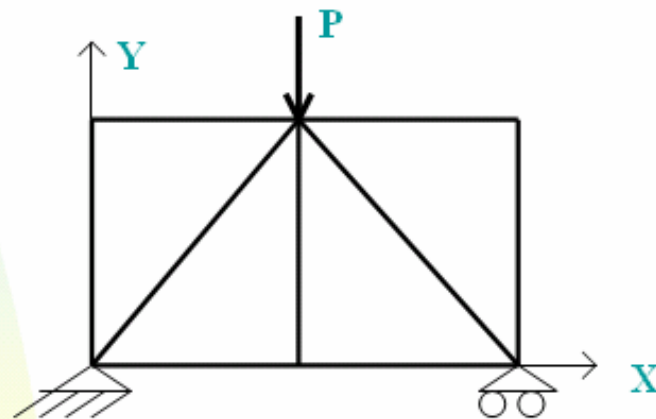

WS2-1

MSC SOFTWARE  
SIMULATING REALITY

- **Background Information (Continued)**
  - **Finite Element Theory**

- The finite elements used to model two and three dimensional truss structures are actually just the simple 2-node bar elements spatially extrapolated to function in two or three dimensional space. This spatial extrapolation is in the form of a transformation of the axial direction of the arbitrarily oriented bar into the global (fixed) coordinate system. The results of the transformation is found in the following stiffness matrix for the two dimensional case.

$$K = \frac{A E}{L} \begin{bmatrix} c^2 & cs & -c^2 & -cs \\ cs & s^2 & -cs & -s^2 \\ -c^2 & -cs & c^2 & cs \\ -cs & -s^2 & cs & s^2 \end{bmatrix}$$

- where the order of the degrees of freedom is . The A, E, and L are the cross sectional area, Young's (elastic) modulus and axial length respectively. The c and s in the matrix stand for Cos () and Sin () respectively. The orientation of the bar and the angle are shown below.

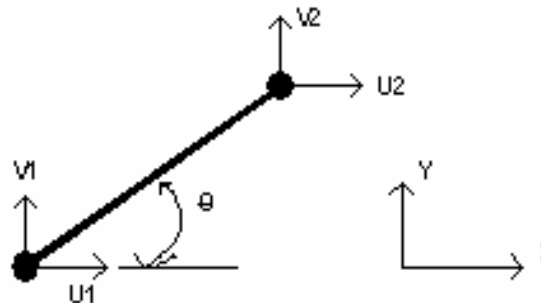



## ■ Problem Description

### ◆ Model Definition

- ◆ The truss structure shown below has nine members. Each of the members is made of aluminum and each has the same cross sectional area. The lower left corner of the structure is constrained in all three directions. The lower right hand corner is constrained in the Y and Z directions, but is free to roll in the X direction. A vertical load of 100 Newtons is applied at the midpoint of the top of the truss. The loading is directed downward. The truss geometry is symmetric about the vertical line through the point at which the force is applied. Material properties, as well as physical dimensions, are given below.

- ◆ For the truss:
- ◆ Young's modulus = (Aluminum)
- ◆ Poisson's ratio = 0.3
- ◆ Truss members are (3 cm X 3 cm) square

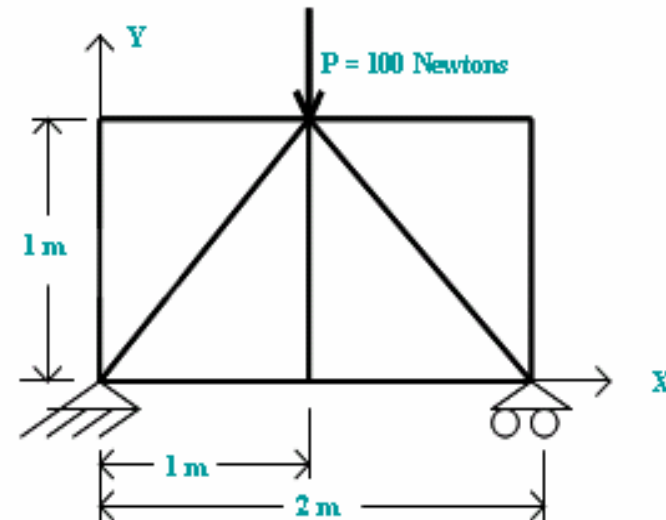

## Step 7. Results: Create / Quick Plot

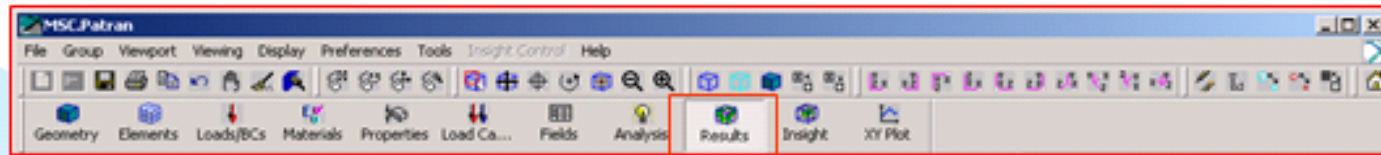

### Plotting results (Stresses)

- Results: Create / Quick Plot
- Select Results Cases: Default, Static Sub case
- Select Fringe Result: Stress Tensor
- Quantity: X Component
- Select Deformation Results: Displacement, Translational
- Apply

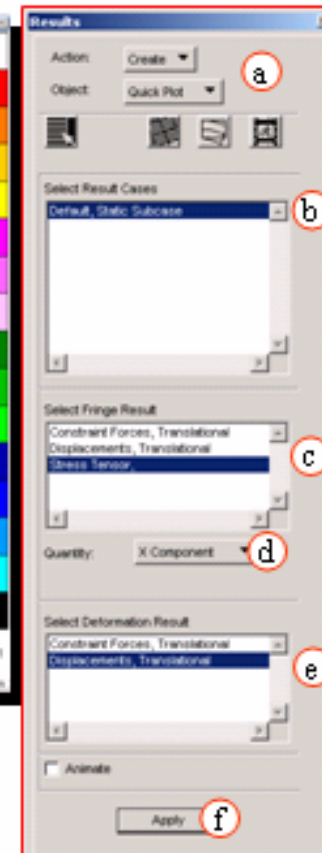
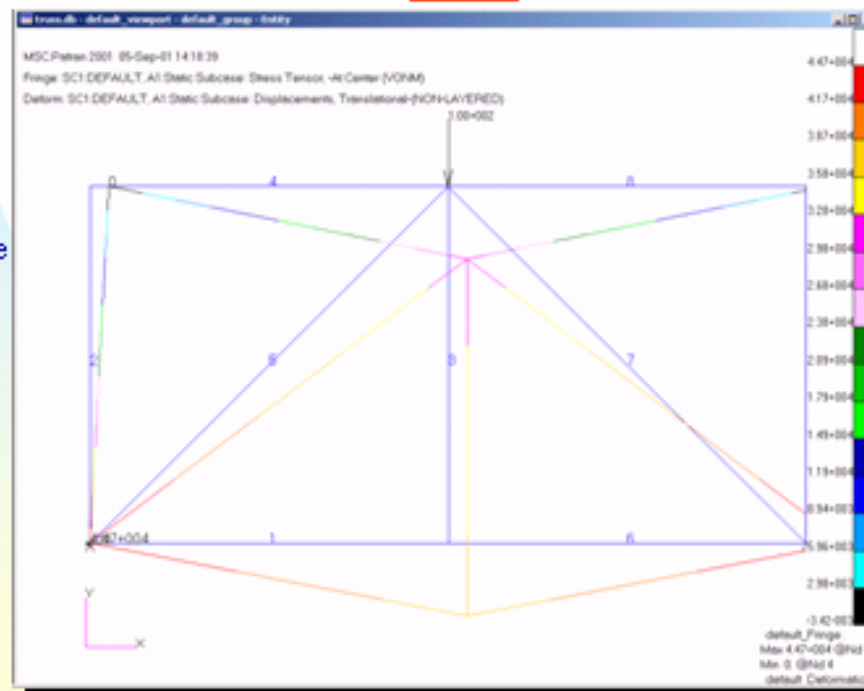

## ◆ Exercises

The questions below refer to the truss model described at the beginning of this tutorial. Also, information from the output file truss.f06 will be needed in order to answer many of these questions. As used below, the term "**member**" refers to the portion of a truss structure between two joints. For example, the top of this structure has two horizontal members which are connected by the joint at which the load is applied.

- 1a. What is the maximum displacement for the structure ?
- 1b. Is this displacement consistent in location, magnitude and direction with your physical intuition ?
- 2a. What is the maximum stress in the structure ?
- 2b. Is this stress consistent in location, magnitude and direction with your physical intuition ?
3. Are there any members with very low stresses? Does this make physical sense?
4. How many equations are solved in order to determine the displacements for this structure ?
5. What assumptions are involved in using this specific element as opposed to using a 2 node beam element with 6 degrees of freedom (3 displacements and 3 rotations) per node ?
6. The present model uses a single 2-node bar element for each truss member. Would the accuracy of the model increase if two bar elements were used to model each truss member ? Justify your answer.

# Workshop 5

## Fixture

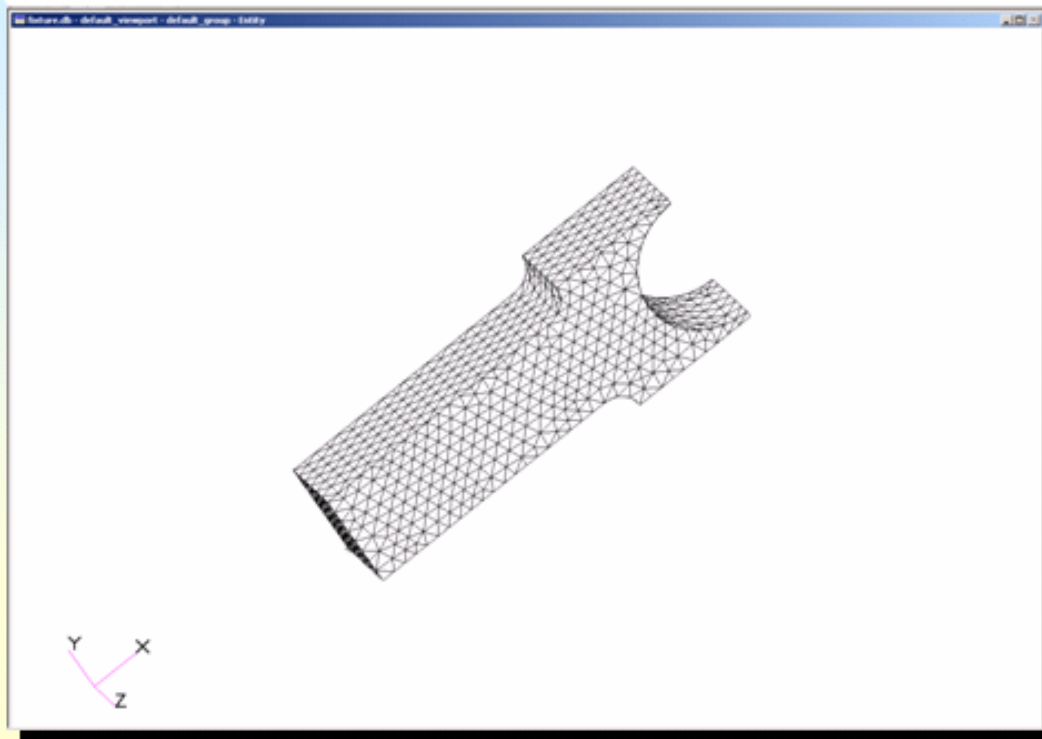

WS5-1

MSC SOFTWARE  
SIMULATOR READY

## Step 7. Results: Create / Quick Plot

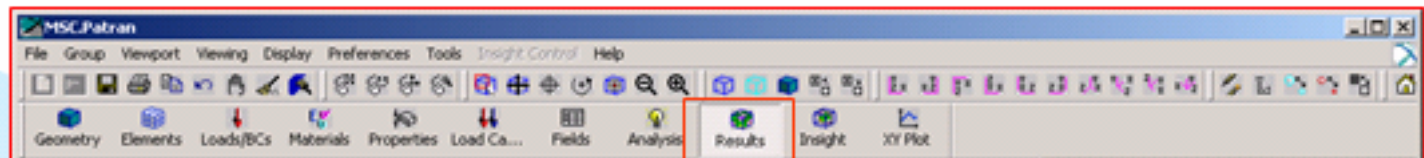

### Plotting results (Stresses)

- Results: Create / Quick Plot
- Select Results Cases: Default, Static Sub case
- Select Fringe Result: Stress Tensor
- Quantity: X Component
- Select Deformation Results: Displacement, Translational
- Apply

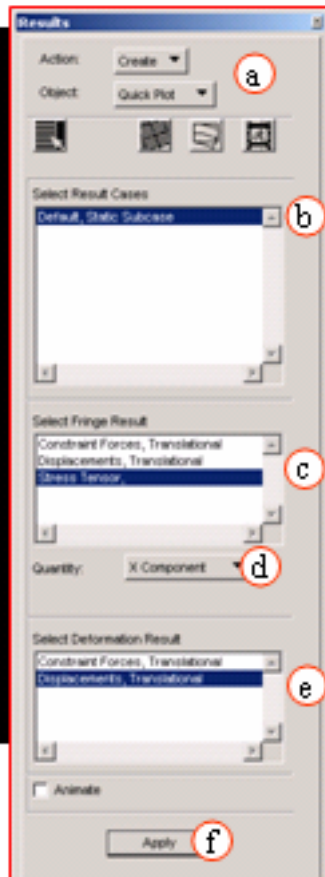
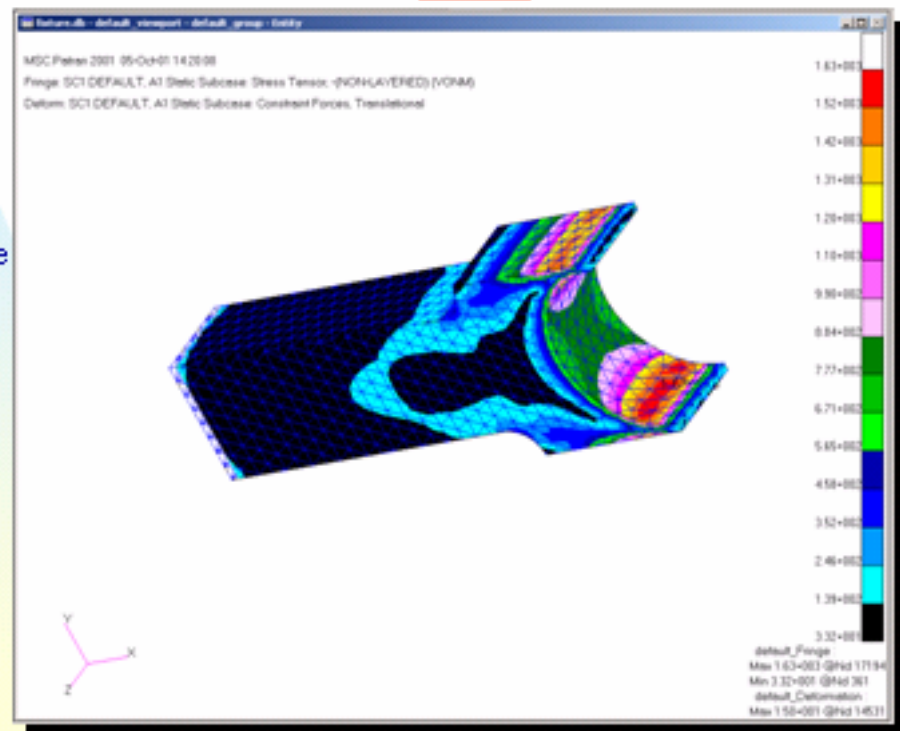

# Step 7. Results: Create / Quick Plot

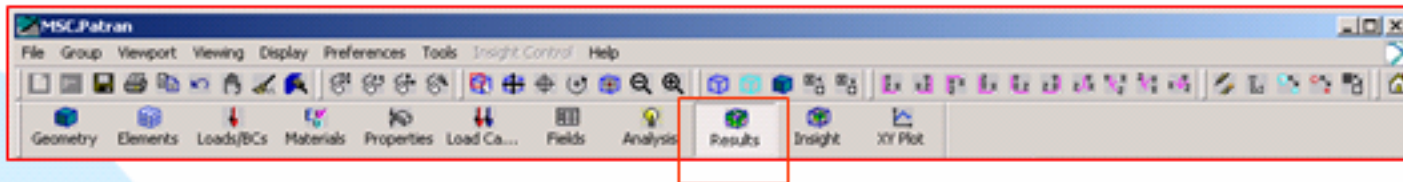

## Plotting results

(Displacements)

- a. Results: Create / Quick Plot
- b. Select Results Cases: Default, Static Sub case
- c. Select Fringe Result: Displacement, Transational
- d. Quantity: Magnitude
- e. Select Deformation Results: Displacement, Transational
- f. Apply

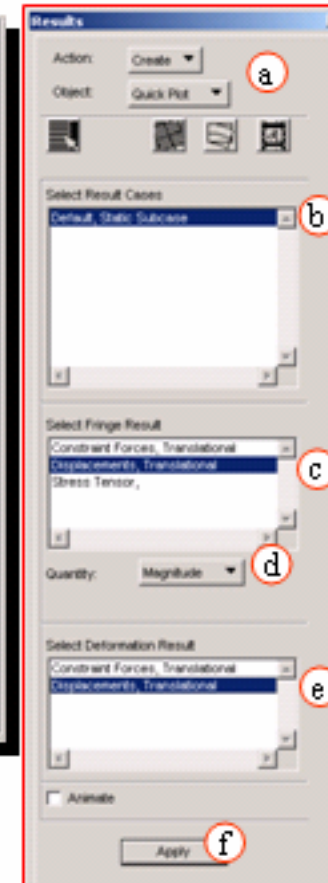
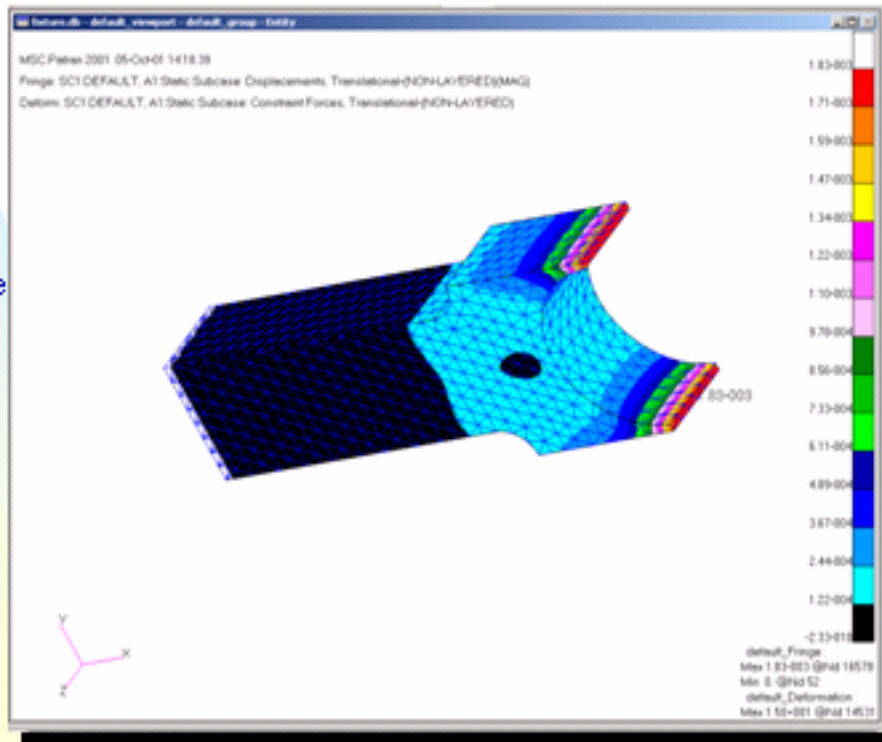



# Student Assessment of the MSC.Nastran Tutorials

## 1. What was most helpful about Tutorials?

Student responses: tutorials provided procedure for analysis step by step process

## 2. What can be done to improve Tutorials?

Student responses: covered what we needed to learn, clean up inconsistent directions, explain in detail why decisions were made in tutorials



# Student Assessment of the MSC.Nastran Tutorials

## 3. Were tutorials easy or hard to use?

Student responses: details were good, fairly easy, took about 2 hours per tutorial, moderately difficult

## 4. Was level of detail in the TEXT appropriate?

Student responses: yes, tutorials told you exactly what to do, details excellent

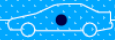

# Student Assessment of the MSC.Nastran Tutorials

## 5. Were the **GRAPHICS** in the tutorials helpful?

Student responses: yes clearly illustrated, easy to follow, they were helpful most of the time, needed some color for pictures

## 6. Did answering the questions at the end help you understand FE?

Student responses: yes, sometimes needless work, made you think about what was accomplished in the tutorial



# Student Assessment of the MSC.Nastran Tutorials

## 7. What do you see as the advantages/disadvantages to learning to use commercial FE software?

Student responses: prepare you to enter the competitive job market with computer engineering experience, advantage fast results to complex problems, disadvantage you could rely on it too much if unsure of analytical FE knowledge.



# Teaching FE using the Kolb Learning Cycle

Students are required to complete a project during this course

Learning Objectives of Project:

- Develop engineering designs for “Real-World Problem”
- Model the problem using MSC.Nastran FE and perform computer analysis of the “best” engineering design
- Verify computer FE analysis using hand FE calculations
- Create prototype model (metal or plastic ) of the problem
- Authenticate FE computer predictions for prototype model’s performance with experimental measurements of the model’s performance under similar constraints and loadings

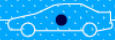

# Student Project MECH 178

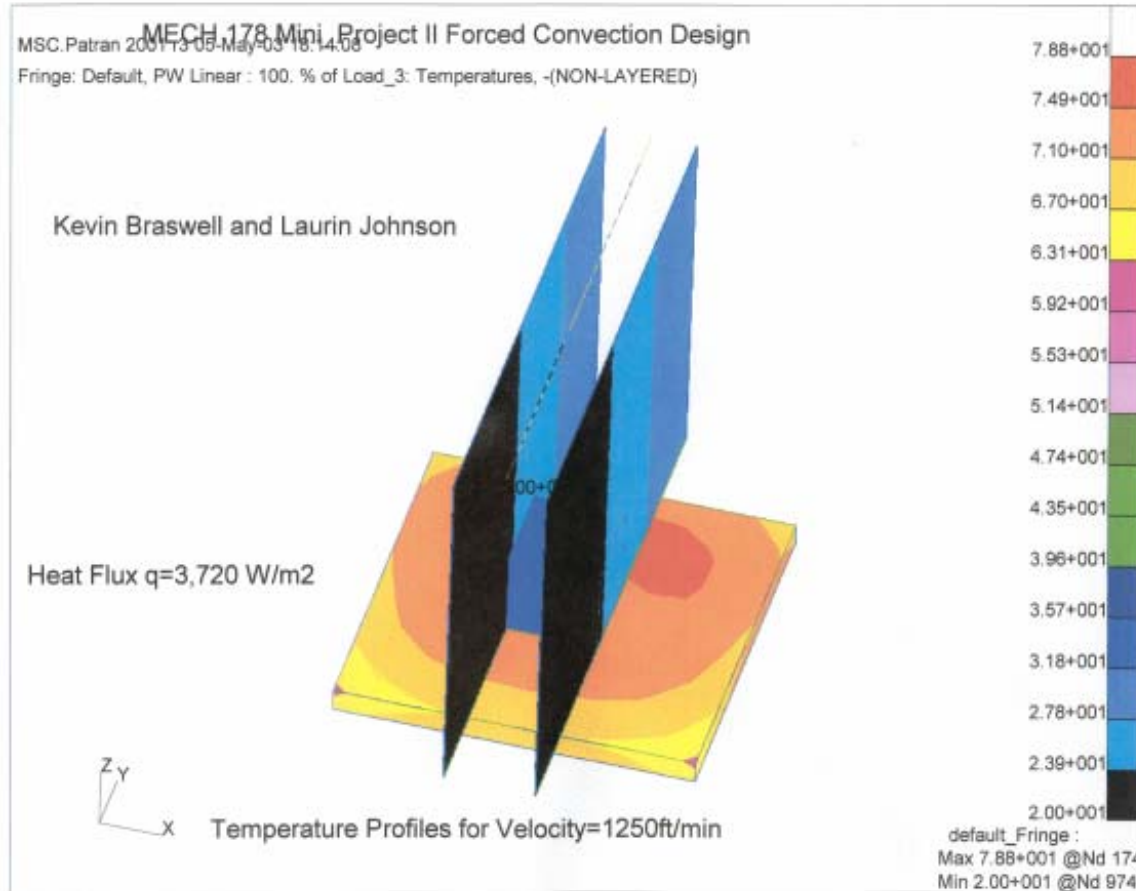

REFERENCE

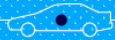

# Student Project MECH 178

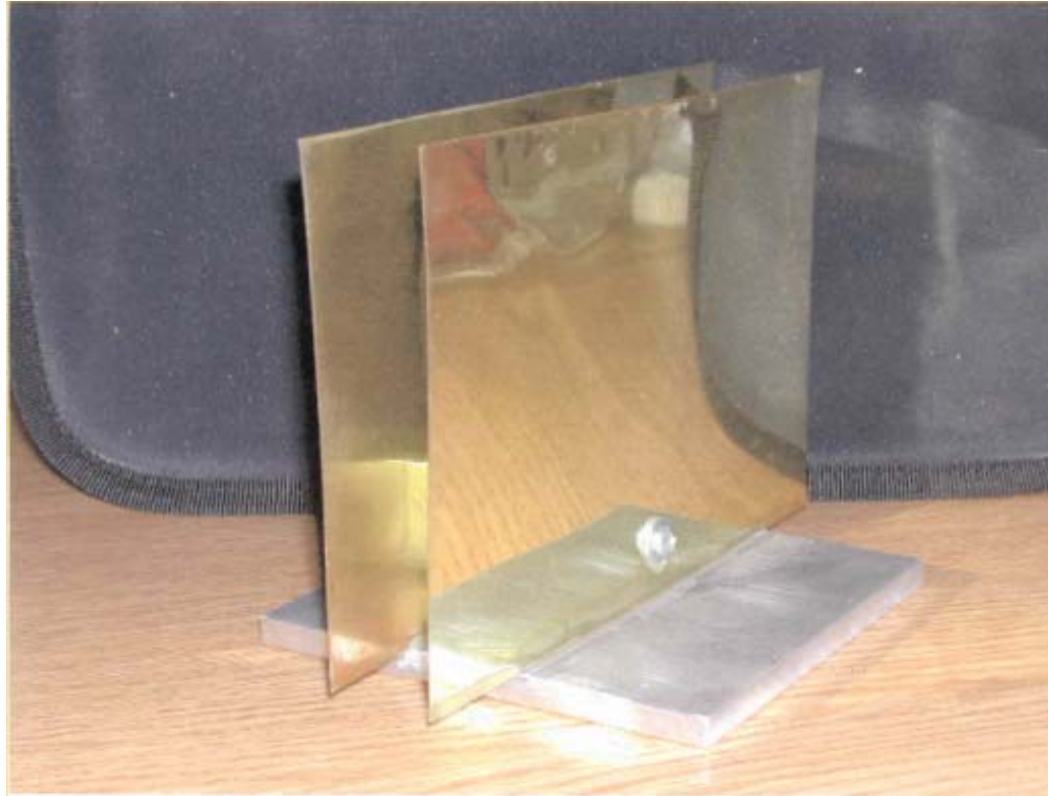



# Student Project for MECH 178

MSC.Patran 2001 13:05 May 03 18:20:27  
 MECH 178 Mini Project II Forced Convection Design

Fringe: Default, PW Linear : 100, % of Load\_2: Temperatures, -(NON-LAYERED)

Jon Frame, Jasem Dhanhani and Jose Solano

Heat Flux  $q = 3,720 \text{ W/m}^2$

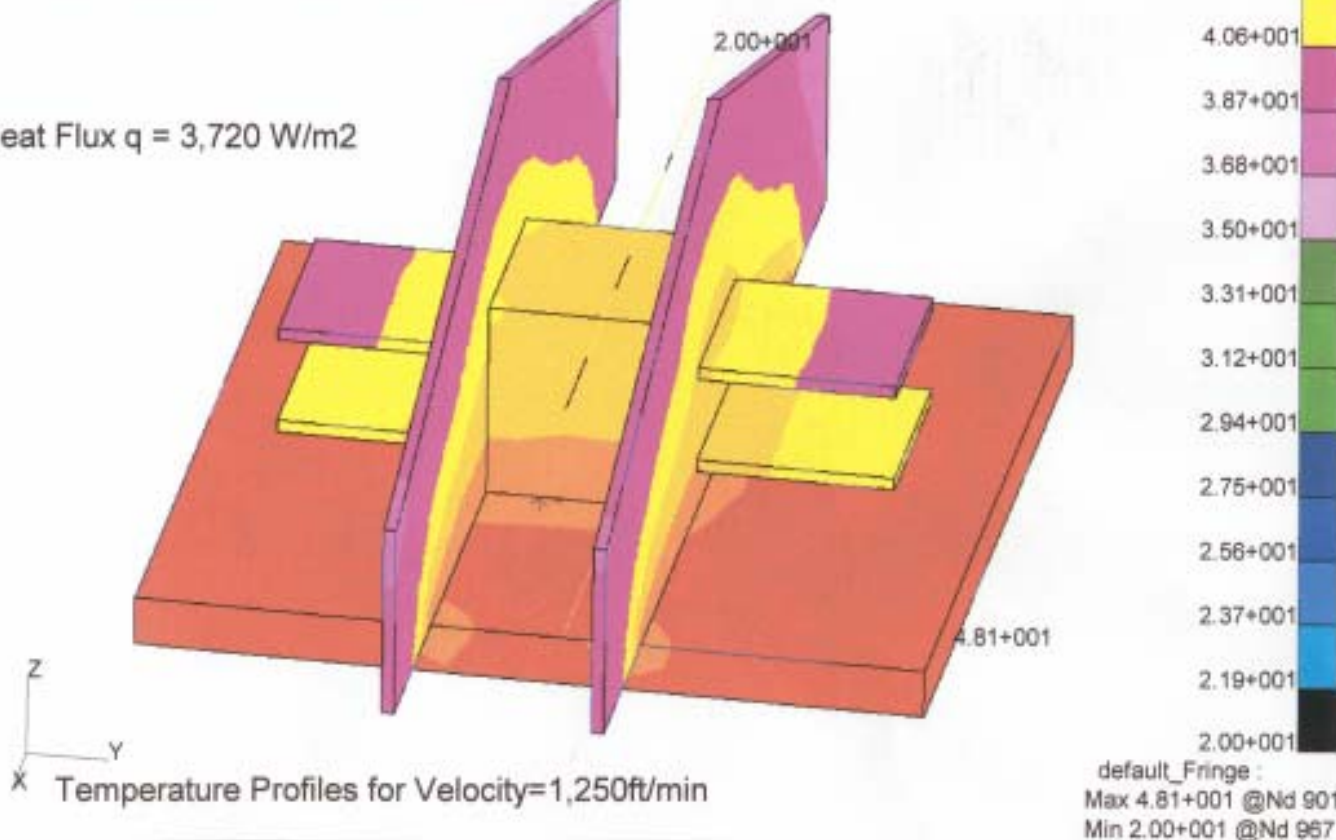



# Student Project MECH 178

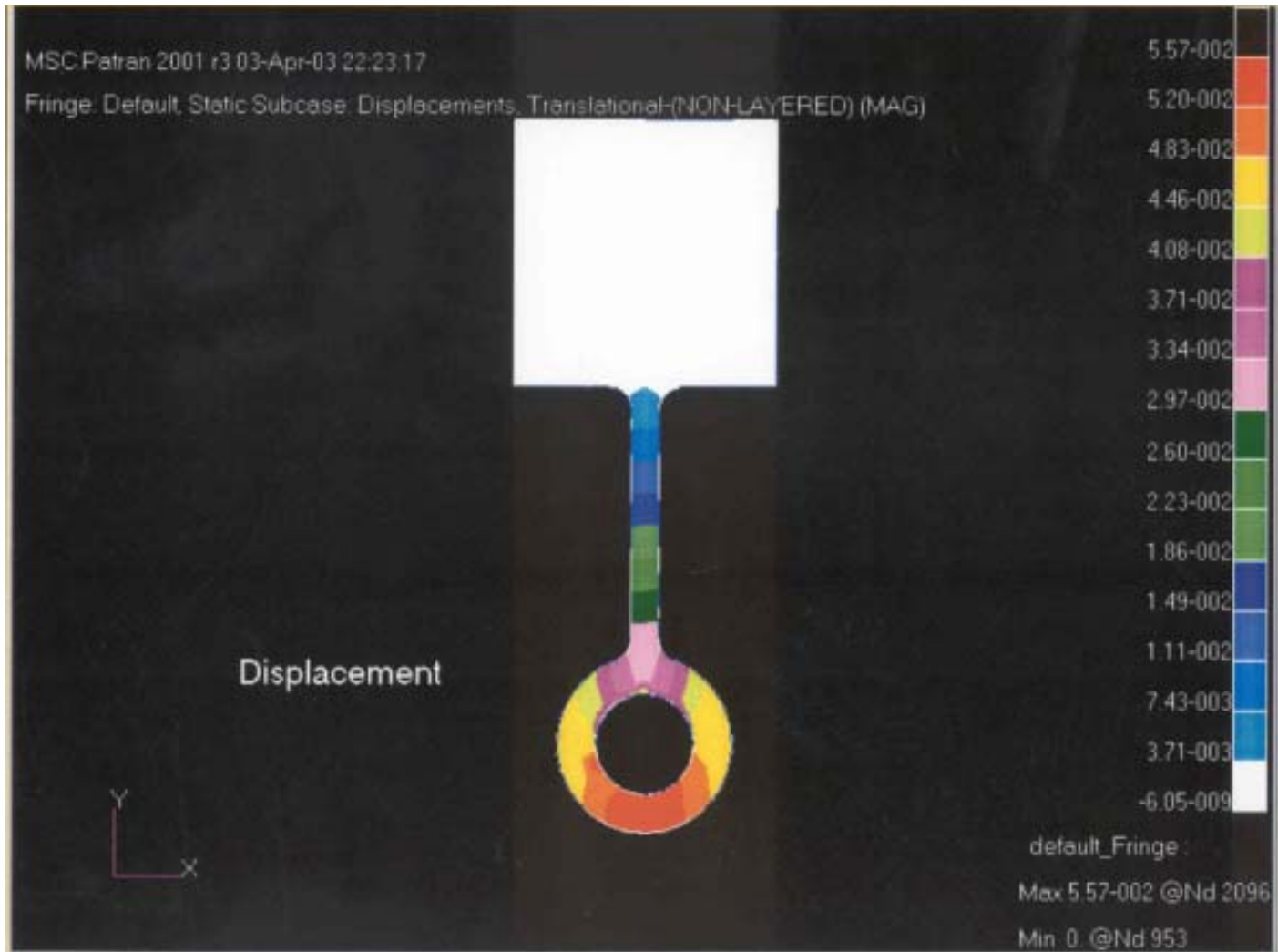

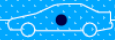

# Student Project MECH 178

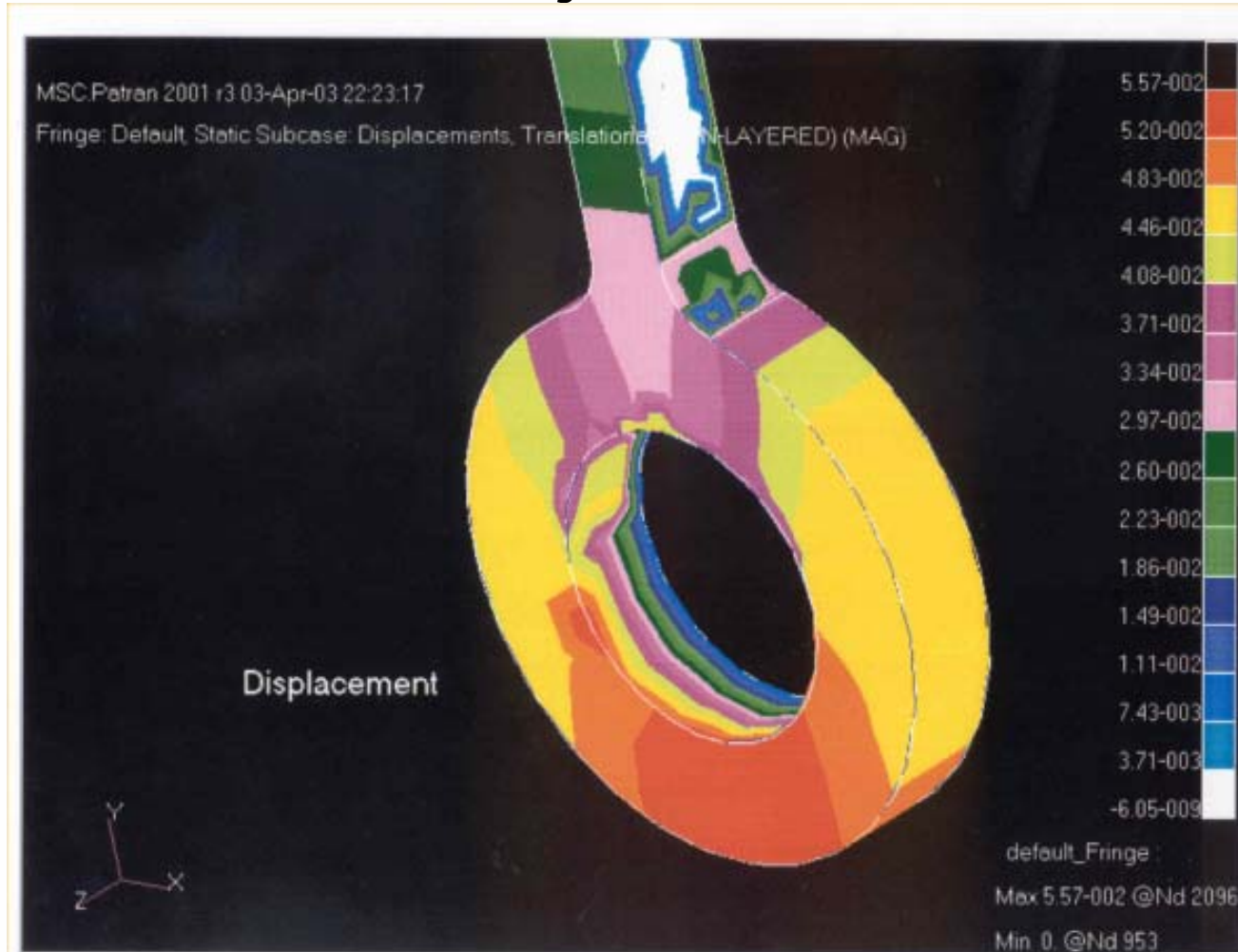

Jon Frame  
Jasmine Noriega



# Teaching Finite Elements Using the Kolb Learning Cycle

**Prof. Ashland O. Brown**

School of Engineering and Computer Science

MSC Software Virtual Product Development Conference

Huntington Beach, California October 18-20, 2004