



An FE Approach to Optimizing Damage Tolerance of Airframe Panels

Raphael Muzzolini, Technical Development Engineer
Alcan Aerospace, Seattle

Sjoerd Van der Veen, Technical Development
Engineer
Alcan Aerospace, Issoire, France

Sylvie Arsene, Numerical Modeling Engineer
Alcan – Pechiney CRV, Voreppe, France



Outline



Design in Aerospace

- Overview
- Damage Tolerance

Alcan's approach

Description of PAnel

Example: Crack Retardation

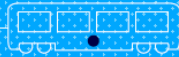

Outline



Design in Aerospace

- Overview
- **Damage Tolerance**

Alcan's approach

Description of PAnel

Example: Crack Retardation

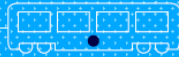

Design: Loading

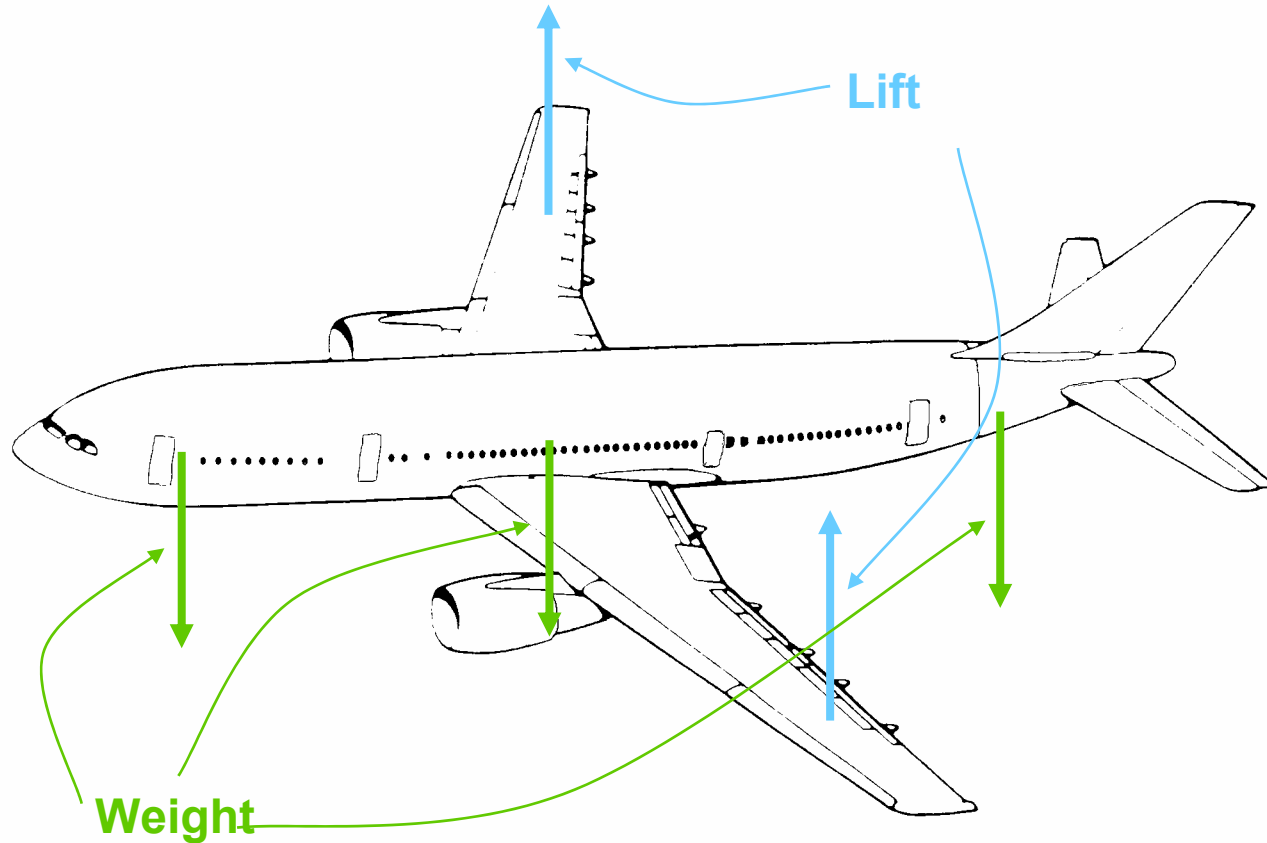

PRODUCT DEVELOPMENT CONFERENCE



Design: Loading

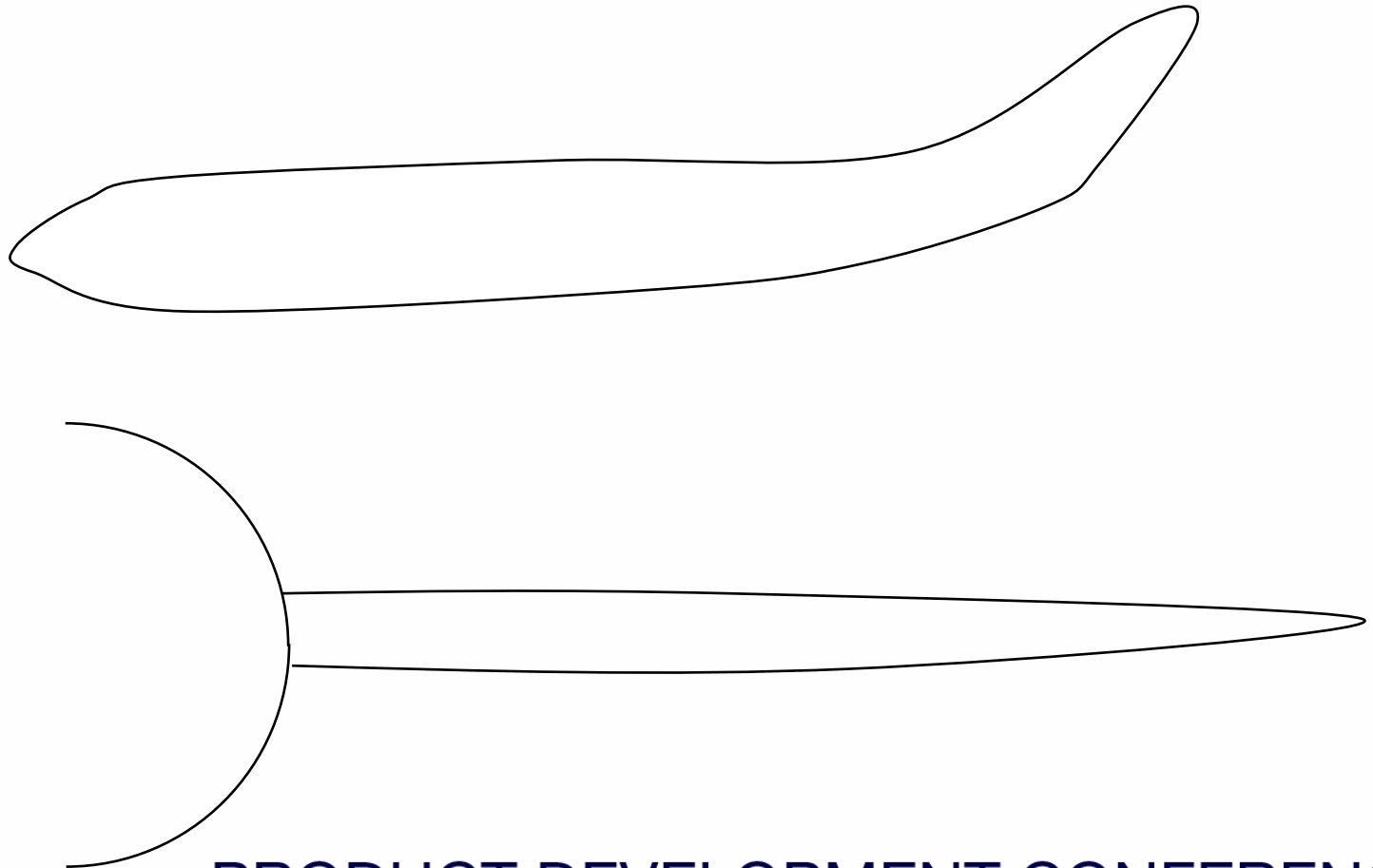

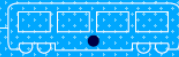
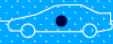

Design: Loading

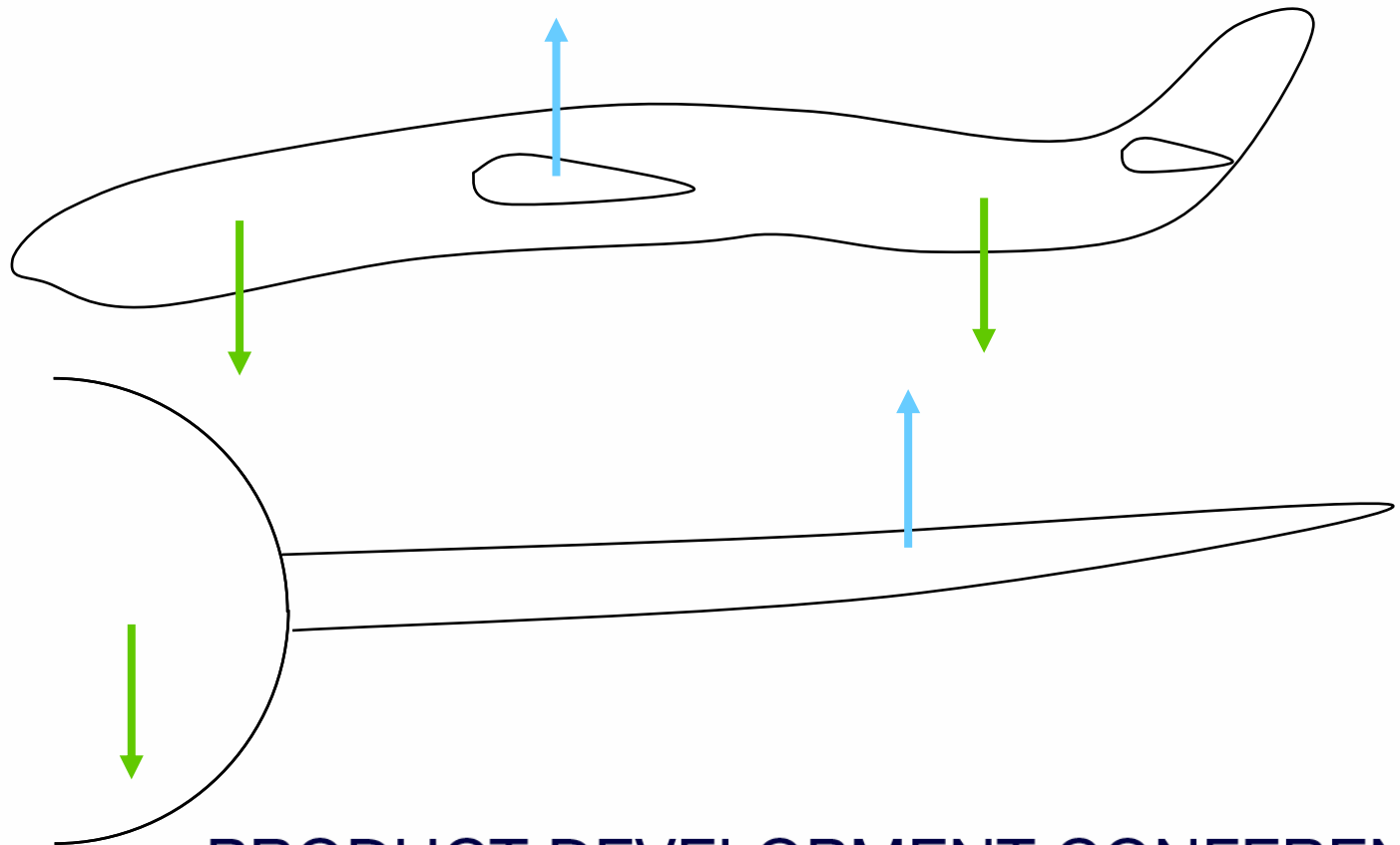

PRODUCT DEVELOPMENT CONFERENCE



Design: Loading

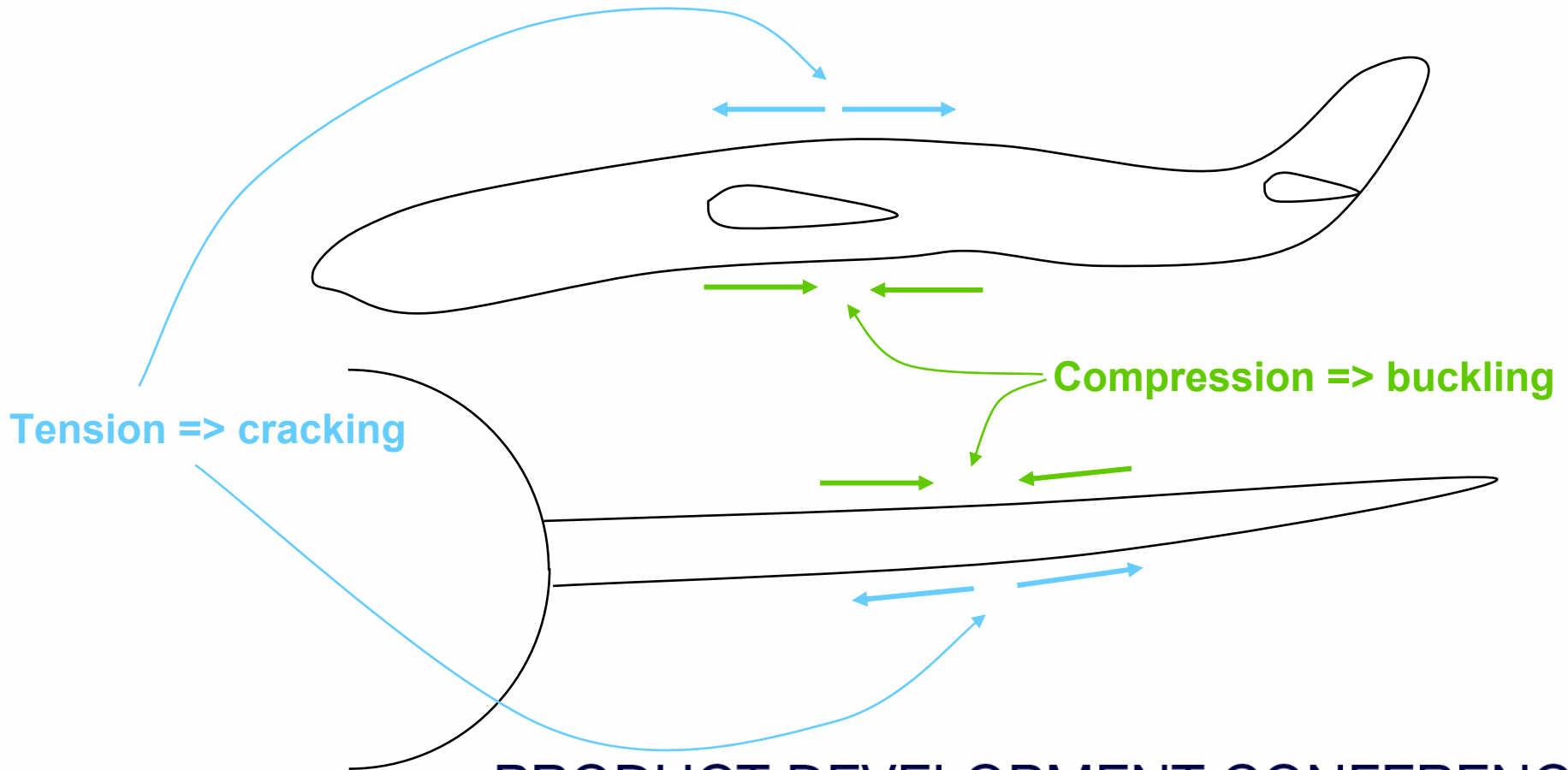

Tension => cracking

Compression => buckling



Design: Structures



Most efficient weight/resistance => stiffened panel

- Skin (curved or flat)
- Stringers in longitudinal direction
- Frames in transverse direction

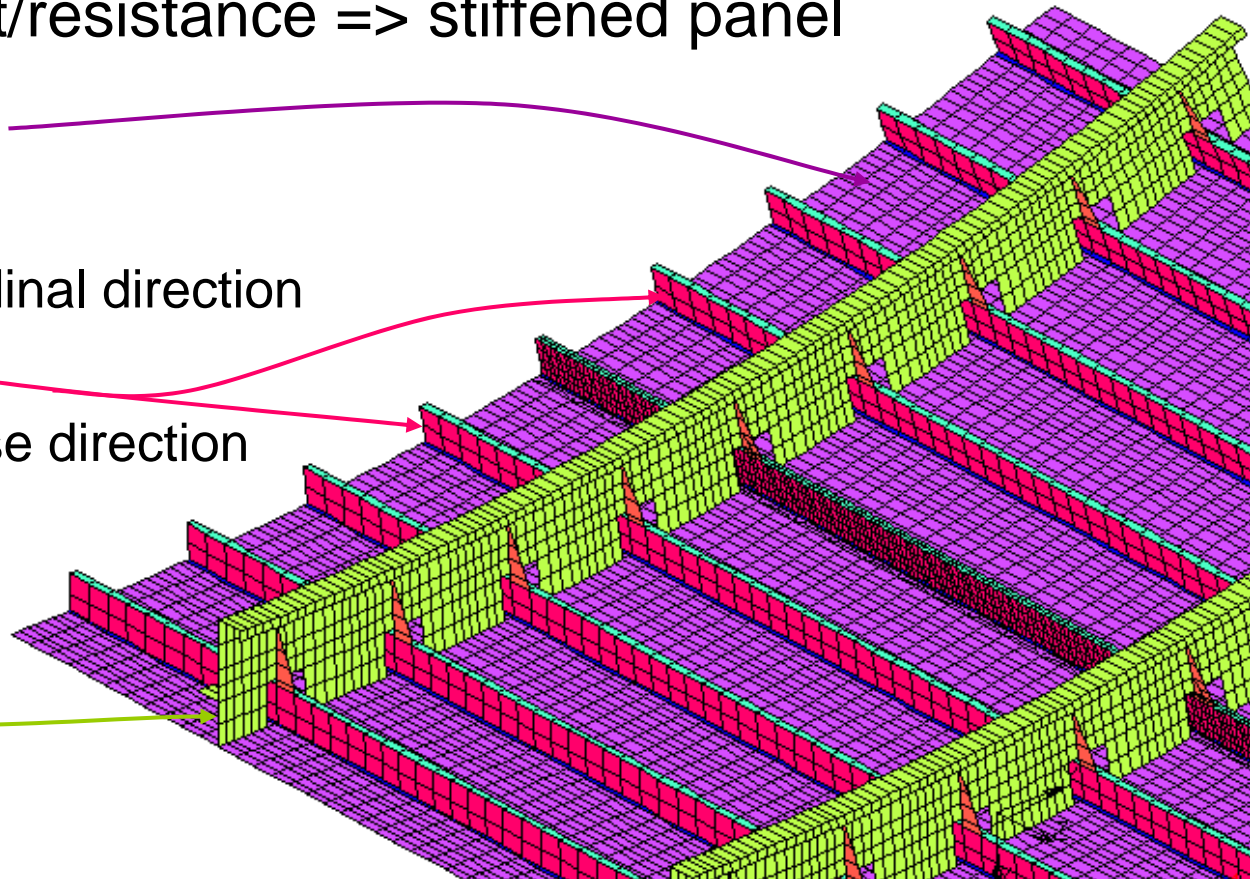

PRODUCT DEVELOPMENT CONFERENCE

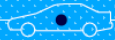

Design: **Damage Tolerance**



DT & Fail-safe approach:

- Slow stable damage growth allowed
- Large damage sustained
- Multiple load path

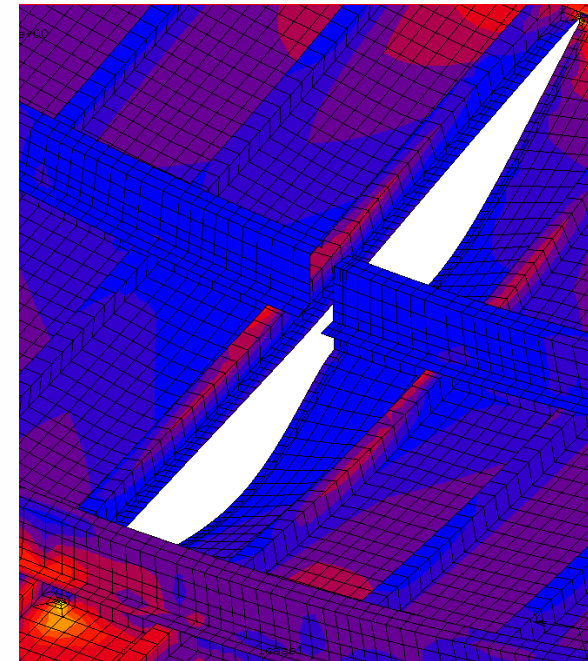

2 frame bay crack

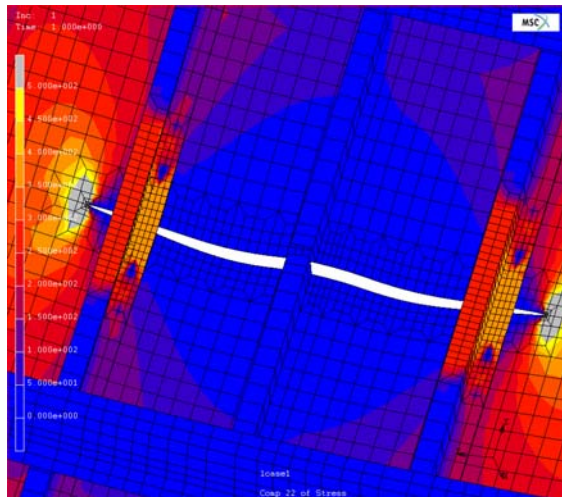

2 stringer bay crack

PRODUCT DEVELOPMENT CONFERENCE



Design: **Damage Tolerance**



Crack initiation

- Number of load cycles generating crack

Testing

Crack propagation

- Initial crack = detectability limit
- Final crack = 2 bay crack
- Propagation time must be > 2 inspection intervals

Testing

SIF

calculation

Residual strength

- Panel with 2 bay crack must sustain ultimate load



Design: Stress Intensity Factor K

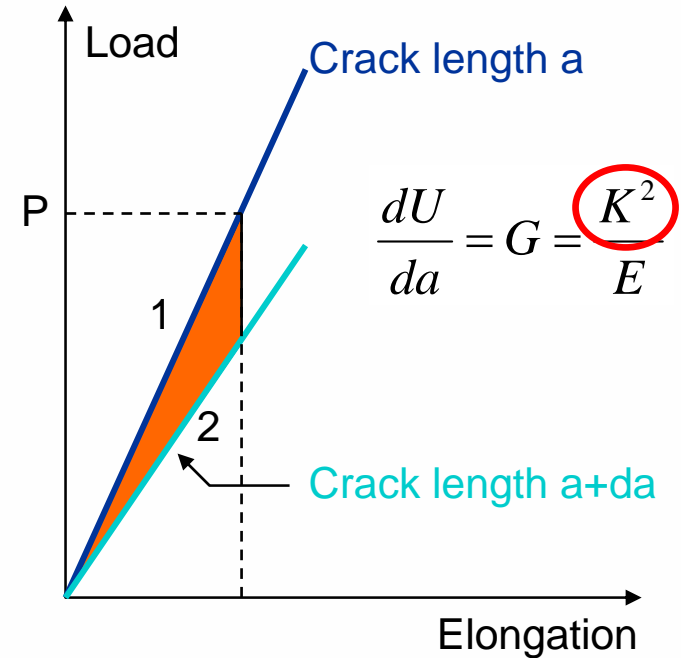
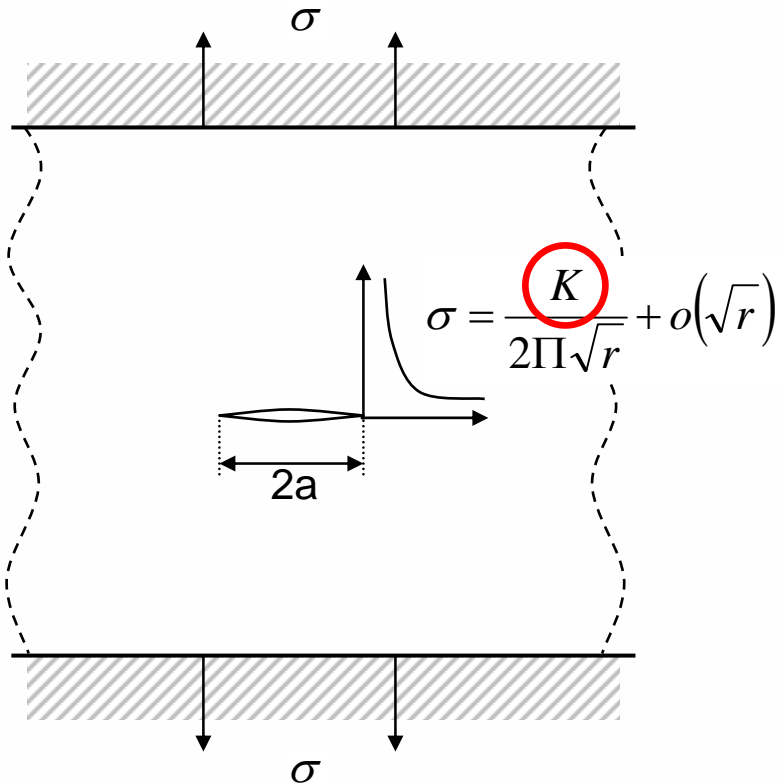

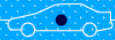

Outline



Design in Aerospace

- Overview
- Damage Tolerance

Alcan's approach

Description of PAnel

Example: Crack Retardation



Alcan's approach



Alcan's core business = metallurgy

- Focus on advanced alloy development

Recent involvement in design

- Understand customer's needs
- Evaluate innovative ideas

Numerical modeling against trials

- Low cost
- Rapidity
- Virtual material

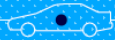

Alcan's approach: FEA



Crack Opening Displacement (COD)

- Measure displacements perpendicular to the crack

$$K_I = \lim_{r \rightarrow 0} \left[E u_2(r) \sqrt{\frac{\pi}{8r}} \right]$$

Strain Energy Release Rate (SERR)

- Small crack extension
- Variation in energy => crack growth

$$K = \sqrt{\frac{E \cdot \Delta W}{t \cdot 2 \Delta a}}$$

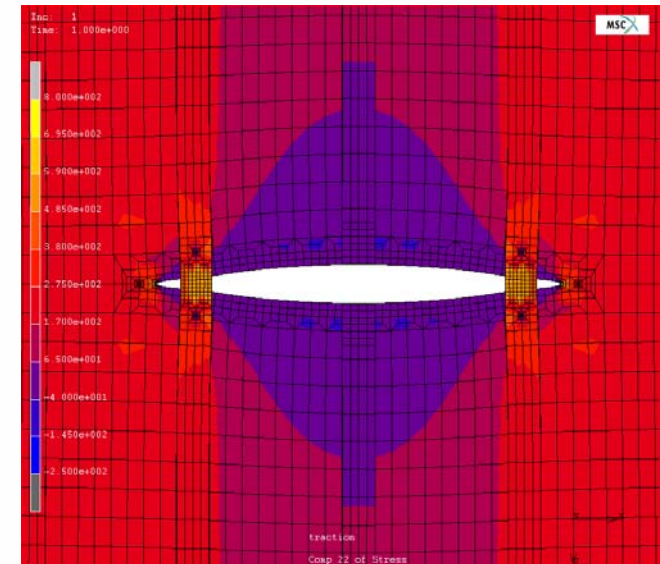



Alcan's approach: FEA



SIF for 20-30 crack lengths

- 2 FEA per crack (SERR method)



40-60
Meshes
Computations
Post treatment...



Need for automation

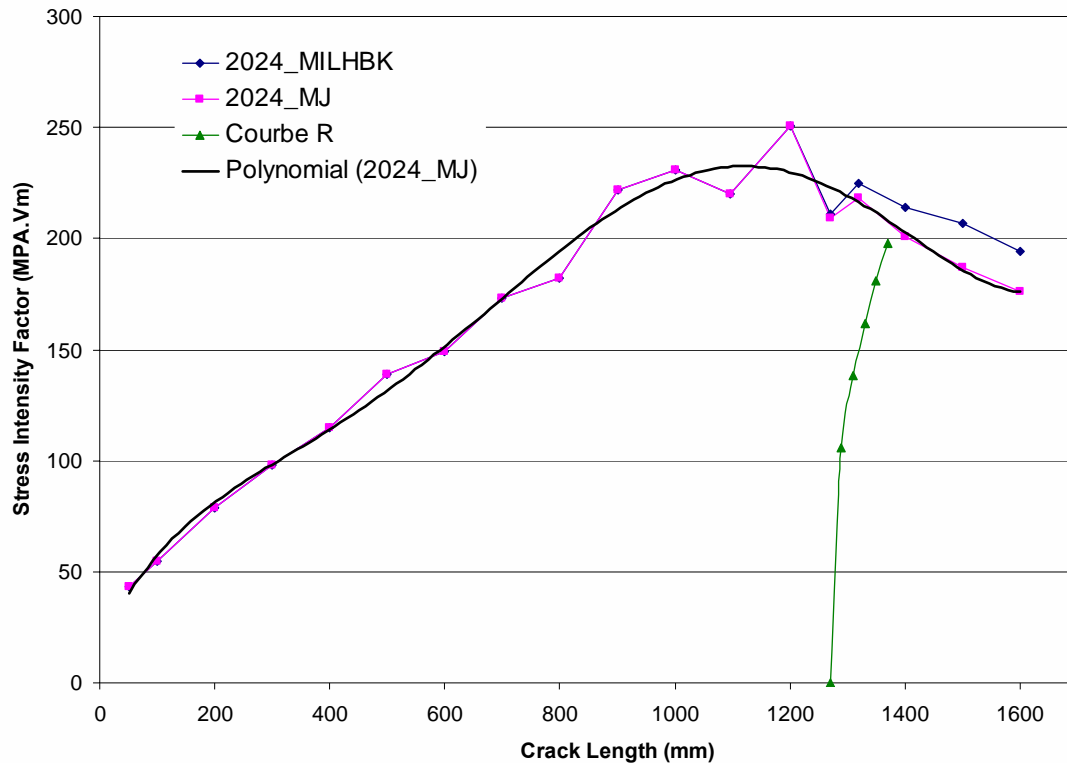

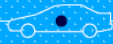

Alcan's approach: FEA



MSC.Marc's Mentat

- Preparation:
 - Automated meshing (procedure)
 - Creates 2 FE input files for a given crack length
- Post-treatment
 - Automatically generate graphs (procedure)
 - Store values in temporary files

MSC.Marc

- Automatically launched
- Perform FE Analysis for all crack lengths
- Save output files (.t16)

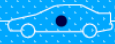

Outline



Design in Aerospace

- Overview
- Damage Tolerance

Alcan's approach

Description of PAnel

Example: Crack Retardation



PAnel: Procedure

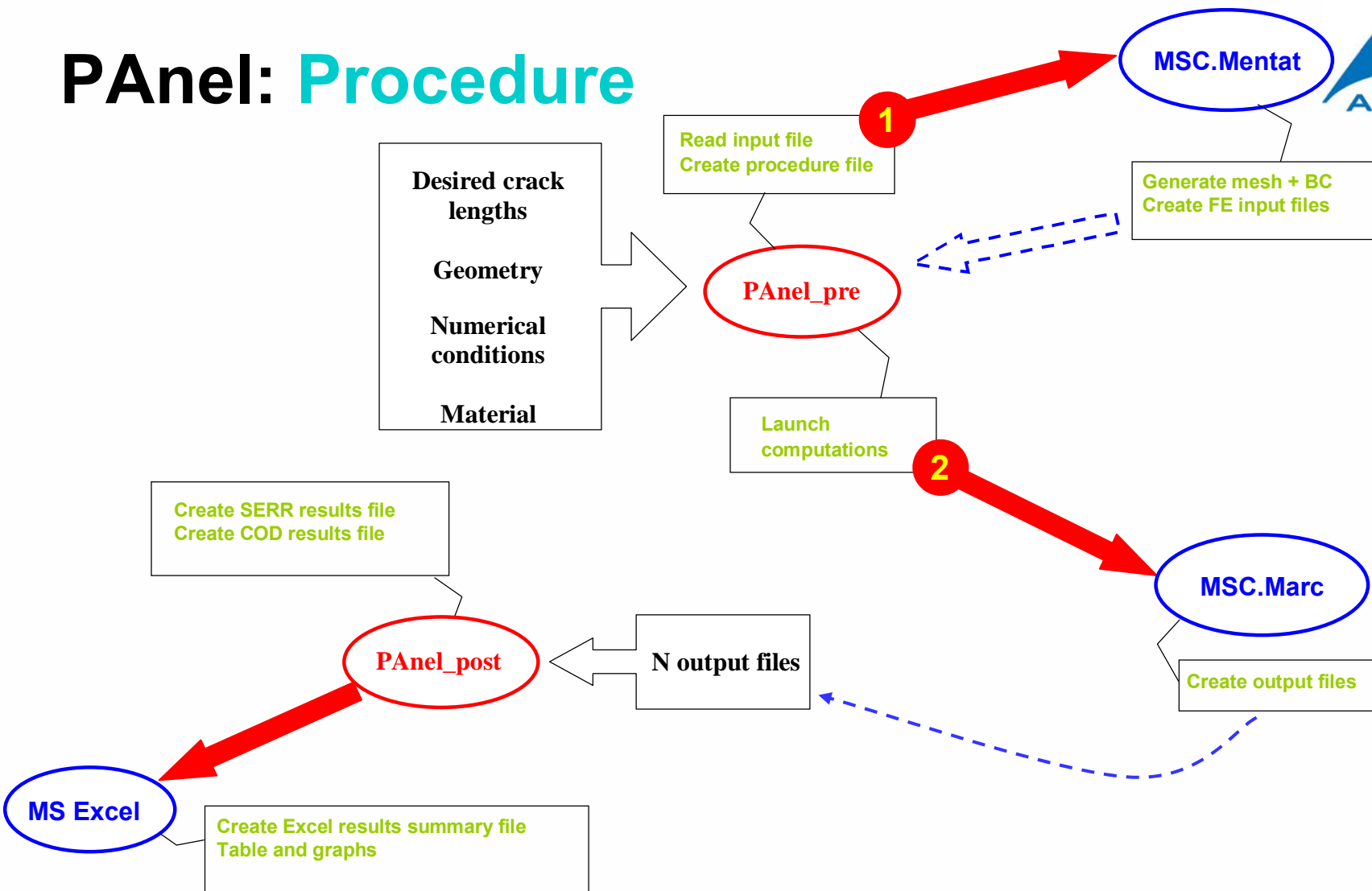

PRODUCT DEVELOPMENT CONFERENCE



PAnel: Input

Text file

- Global parameters (file name, assembly type, position of crack)
- Geometry
- Numerical Modeling
- Material



```

#-----
# boundary conditions
#
main applied displacement in mm           : -1.2718
main applied stress in MPa               : 0.
applied pressure in MPa                  : 0.
side boundary condition (free side/symmetry/load) : free side
# following taken into account if load is chosen
side applied displacement in mm          : 0.
side applied stress in MPa               : 0.
z displacement fixed for skin nodes (yes/no) : yes
#-----

#-----
#
# material
#
stringer material (elastic or plastic): elastic
rivet behaviour (rigid/spring)       : rigid
rivet displacement                    : 0 0.03607 0.08179 0.2542 7.9375 100.
rivet force                            : 0 8007. 10230. 11343. 16383. 18000.
skin young s modulus                  : 71000.
y stringer young s modulus             : 71000.
poisson s ratio                        : 0.33

```

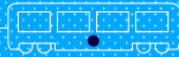

PAnel: Features

Shell elements

- Refinement at the crack tip

Stiffeners

- Complex shape in one direction
- Simple beam in the other direction

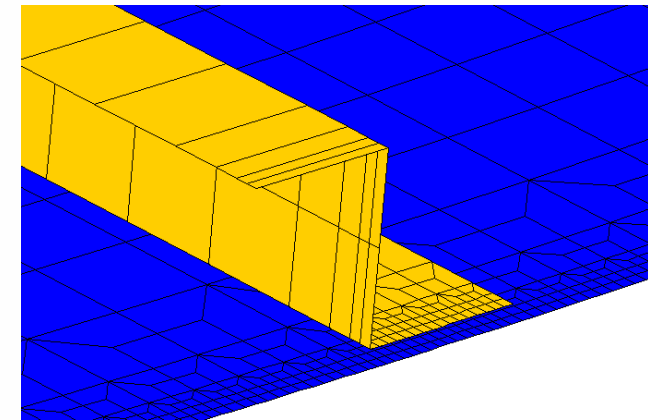
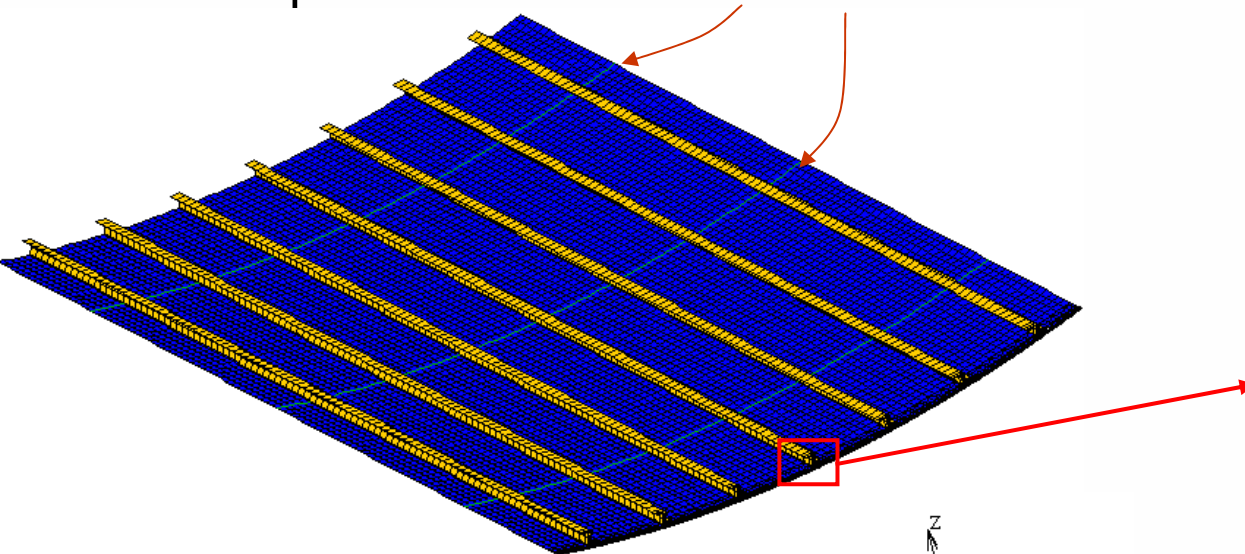
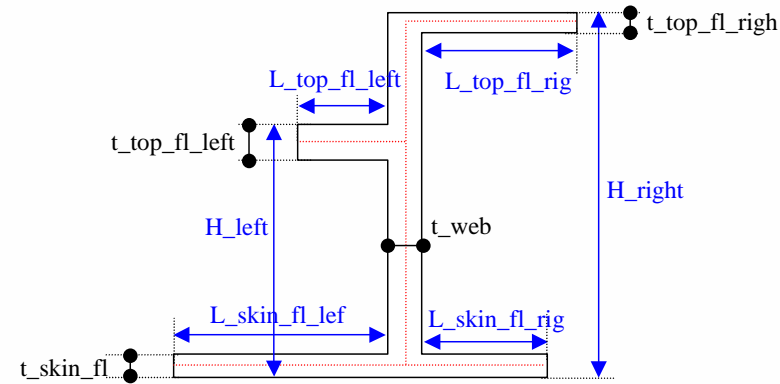

PRODUCT DEVELOPMENT CONFERENCE



PAnel: Features



Boundary conditions

- Transverse symmetry
- Longitudinal edges free or fixed
- Tension: displacement or stress controlled
- Pressurization (fuselage)

3 assembly types

- Rivet = springs
- Integral = shell thickness value
- Bonded = rigid link

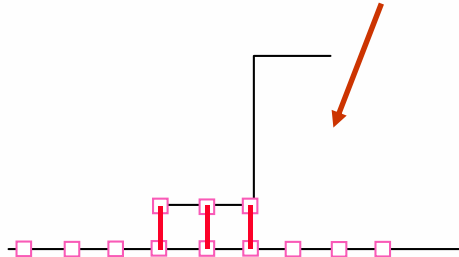
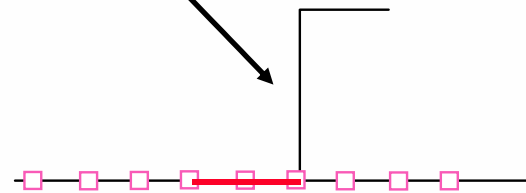
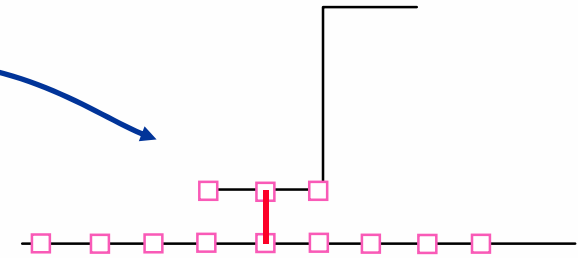

PRODUCT DEVELOPMENT CONFERENCE



PAnel: Results



Transverse or longitudinal cracks (fuselage)

Typical MSC.Marc FE calculation

- Nodal values => displacement
- Integrated value => stress, strain

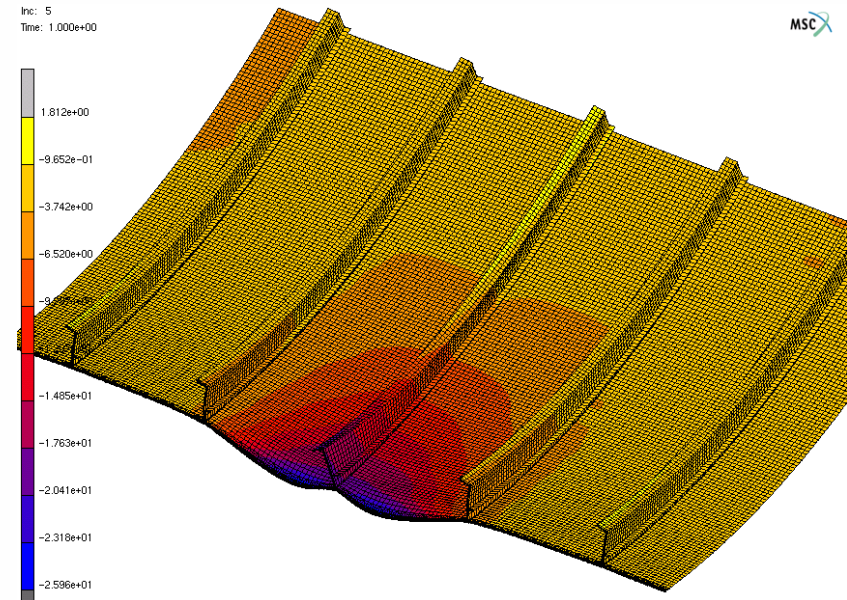
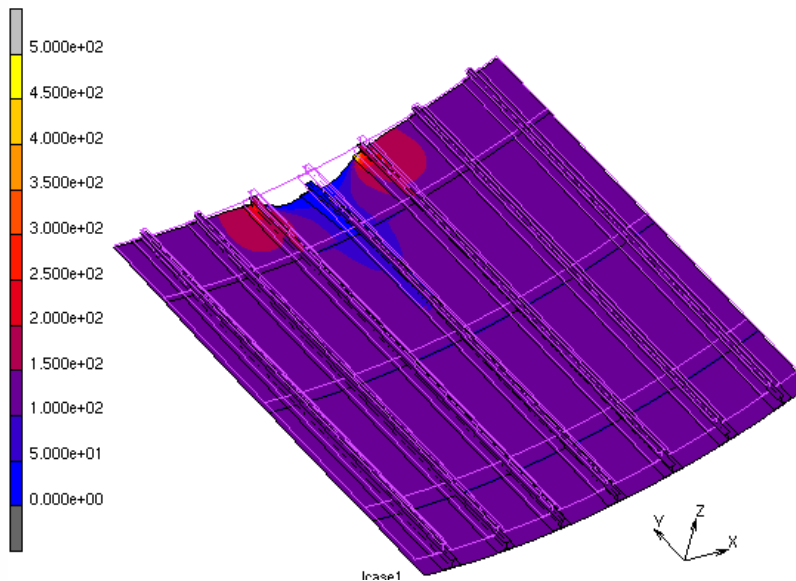

PRODUCT DEVELOPMENT CONFERENCE



PAnel: Results



Post-treatment via MSC.Marc's Mentat

- Fully automated procedure
 - Node path => COD
 - Single value => energy

	A	B	C	D	E	F
1						
2	Right half crack	Left Half crack	Mean Half crack	K CTOD right	K CTOD left	K SERR
3	25.7385	25.584375	25.6614375	52.3456	64.5898	63.27042286
4	51.477	50.883625	51.1803125	67.6319	73.154	75.21530403
5	100.809125	100.21575	100.5124375	85.3493	87.7088	90.89566785
6	130.837375	130.244	130.5406875	98.3792	95.7015	106.1797044
7	150.14125	151.69275	150.917	105.1728	99.9929	109.5806637
8	171.59	170.996625	171.2933125	106.6425	102.9173	110.4289678
9	180.118125	181.721	180.9195625	104.5429	102.7094	106.1455765
10	190.351875					97.84852829
11	200.585625					93.71383031
12	205.314625					71.80352312
13	211.74925	210.819375	211.2843125	84.9304	96.2862	83.82522112
14	220.32875	221.053125	220.6909375	83.9753	86.0473	80.30473234

VB MS.Excel Macro

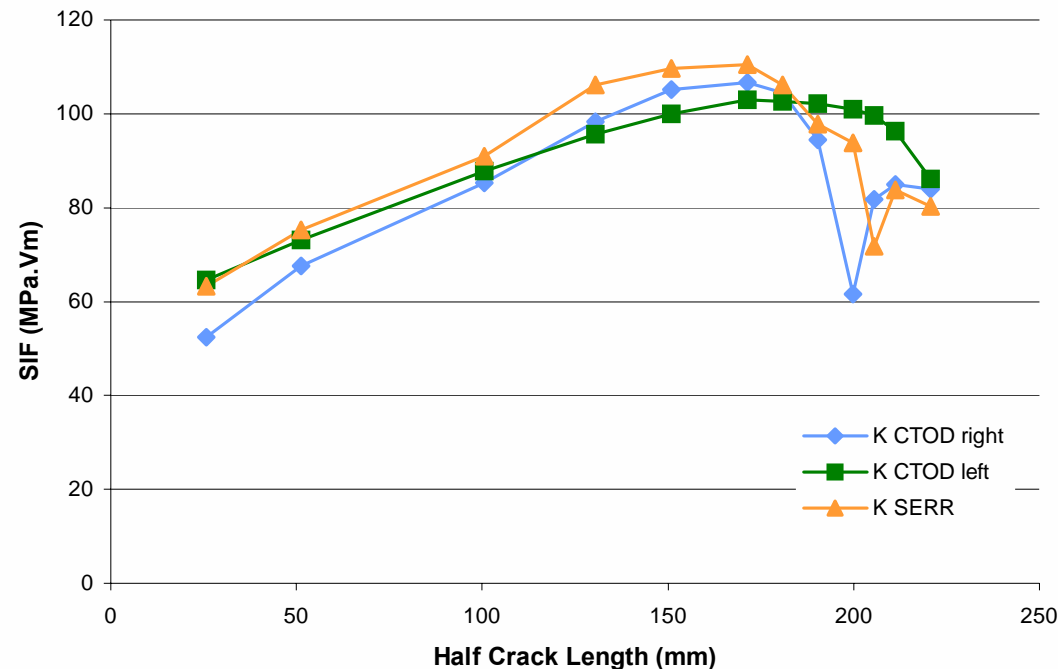

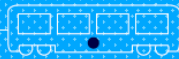

Outline



Design in Aerospace

- Overview
- Damage Tolerance

Alcan's approach

Description of PAnel

Example: Crack Retardation



Example: Integral structures



+

- Lower cost
 - Reduced assembly
 - Reduced number of parts
- Extra-stiffness & Fatigue
- Geometry easily customized

-

- Not intrinsically damage tolerant

Built-up

- Crack stopping

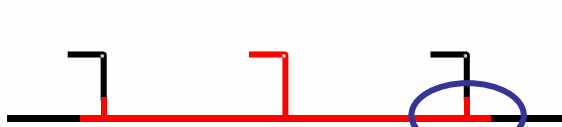

Integral

- Propagation in stiffener

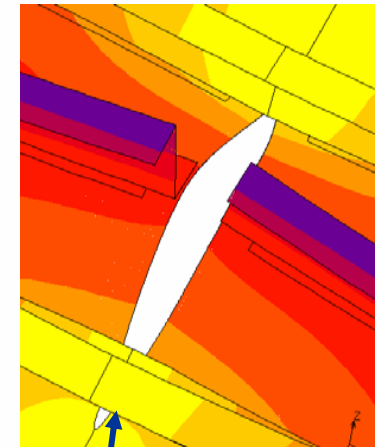
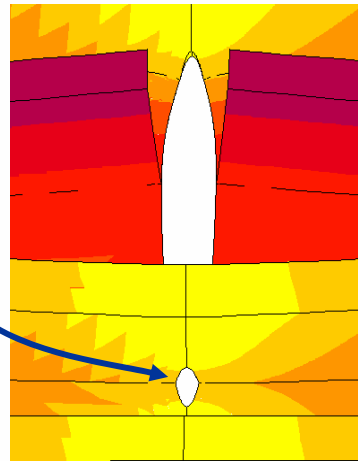

PRODUCT DEVELOPMENT CONFERENCE



Example: Integral structures



Idea = Customize stiffener shape

- Minimize crack growth

3 configurations tested with PAnel = same weight

- T shape

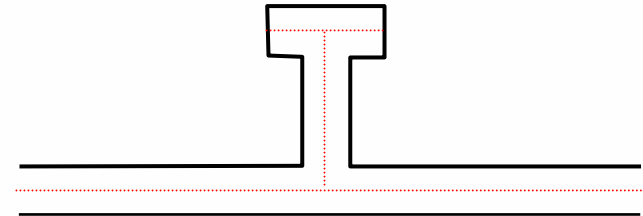

- Rectangular pad-up

- Rectangular pad-up with halved stringer pitch





Example: SIF results

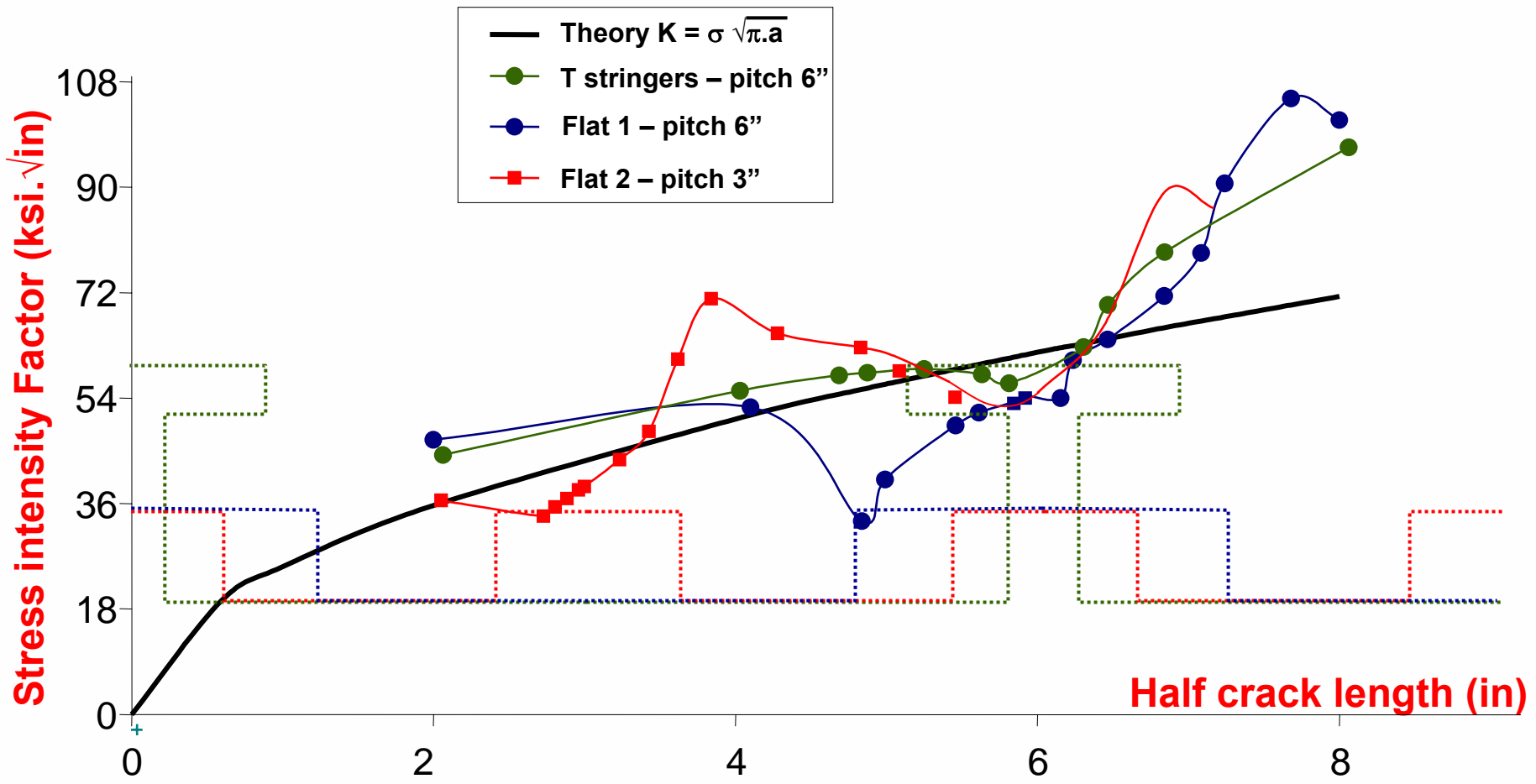

PRODUCT DEVELOPMENT CONFERENCE



Example: SIF results

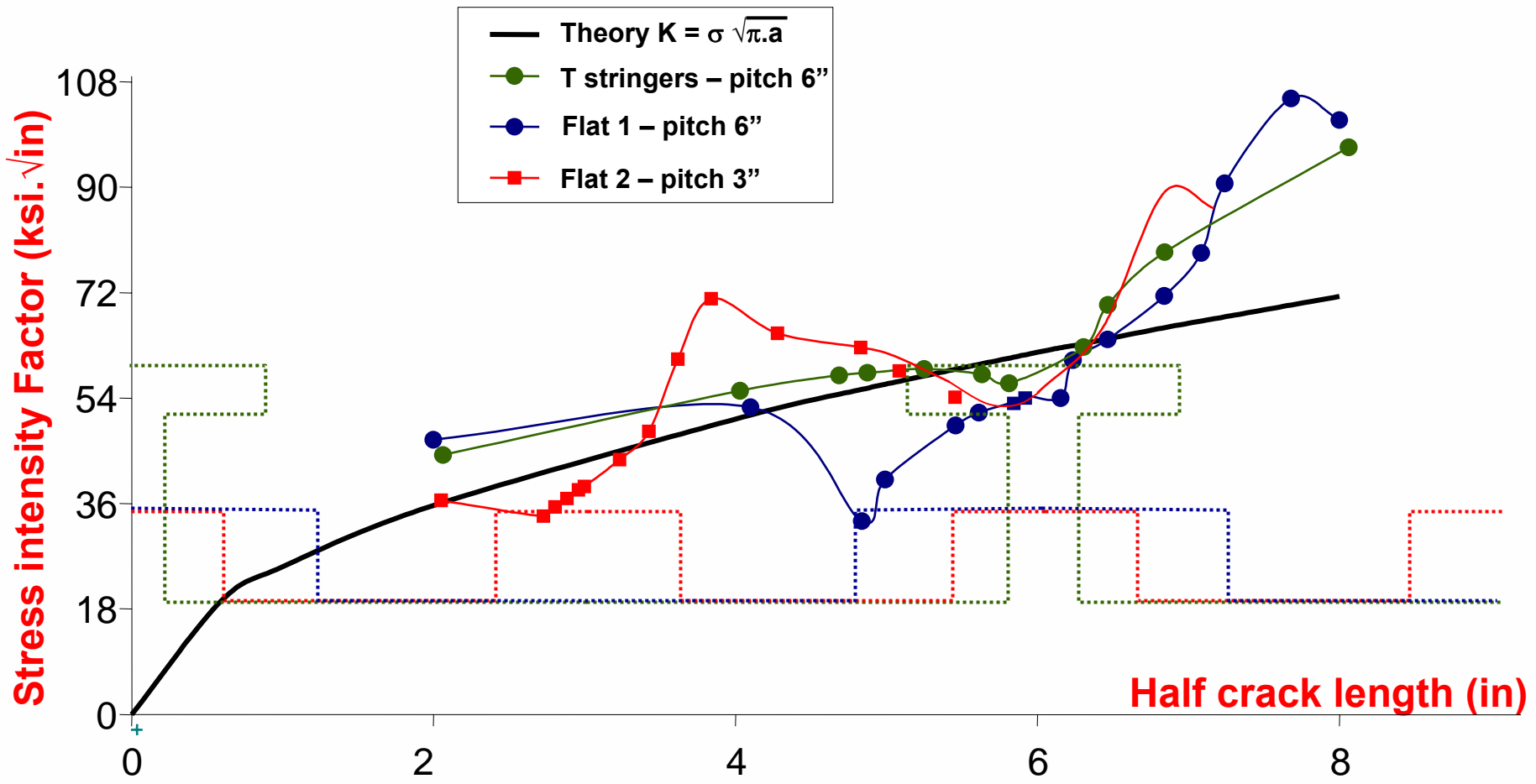

PRODUCT DEVELOPMENT CONFERENCE



Example: Crack propagation life



Biking analogy

- Slower then faster can imply slower overall

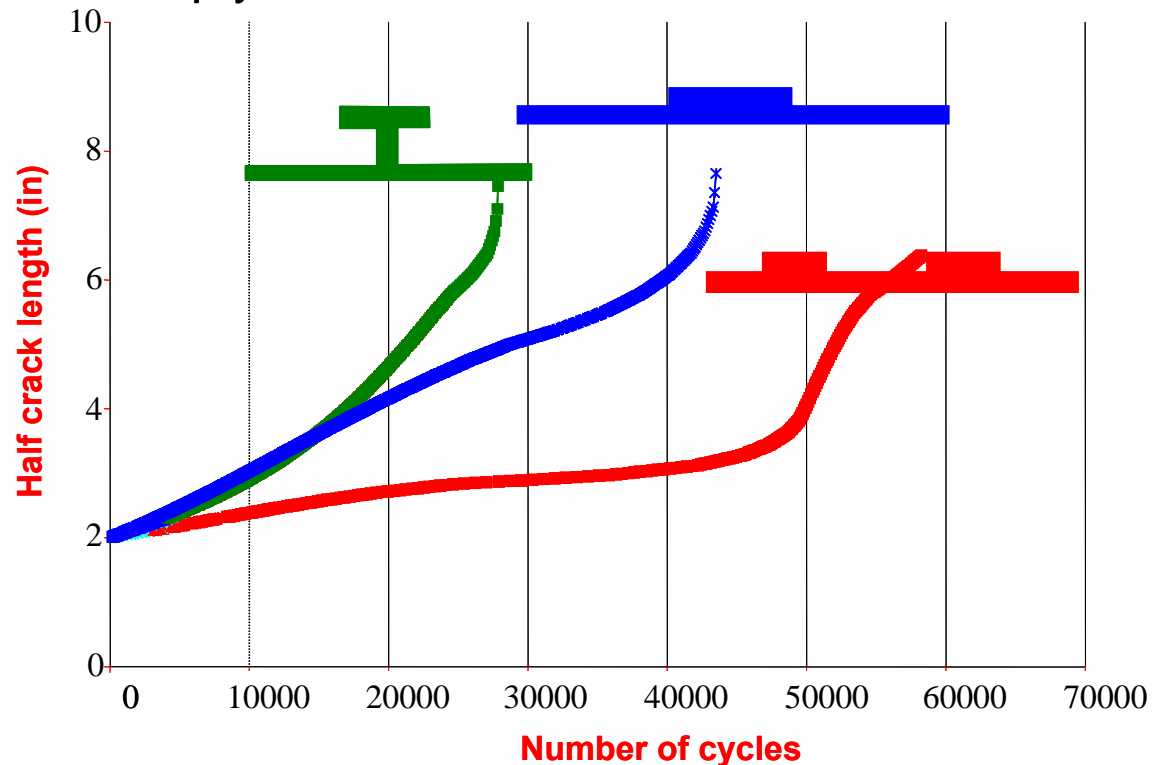

PRODUCT DEVELOPMENT CONFERENCE



Crack retardation: Test definition



Parametric study => minimize crack propagation

- Number of pad-ups (crenellations)
- Height and width of pad-ups

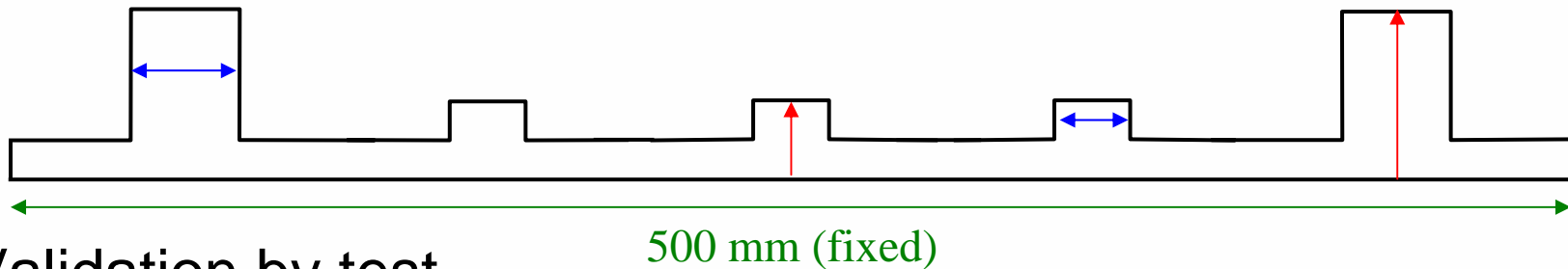

Validation by test

- Crenellated and control panels
- Same overall section => same weight

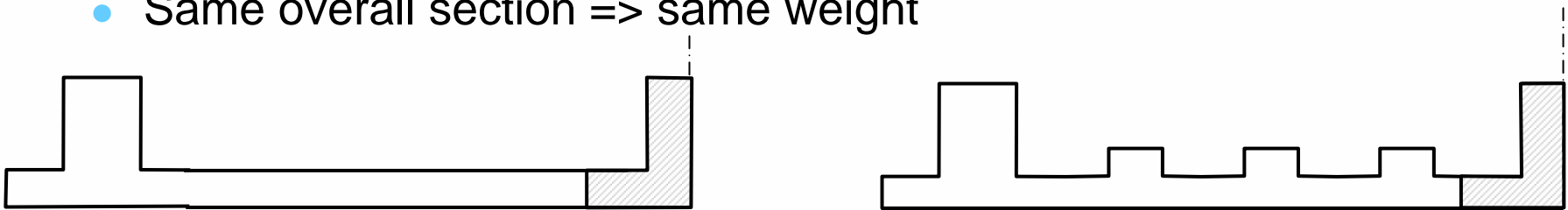

PRODUCT DEVELOPMENT CONFERENCE

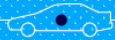

Crack retardation : Testing



2027 T351 Lower wing skin alloy study

Constant amplitude $R=0.1$, $\sigma_{\max} = 70$ MPa

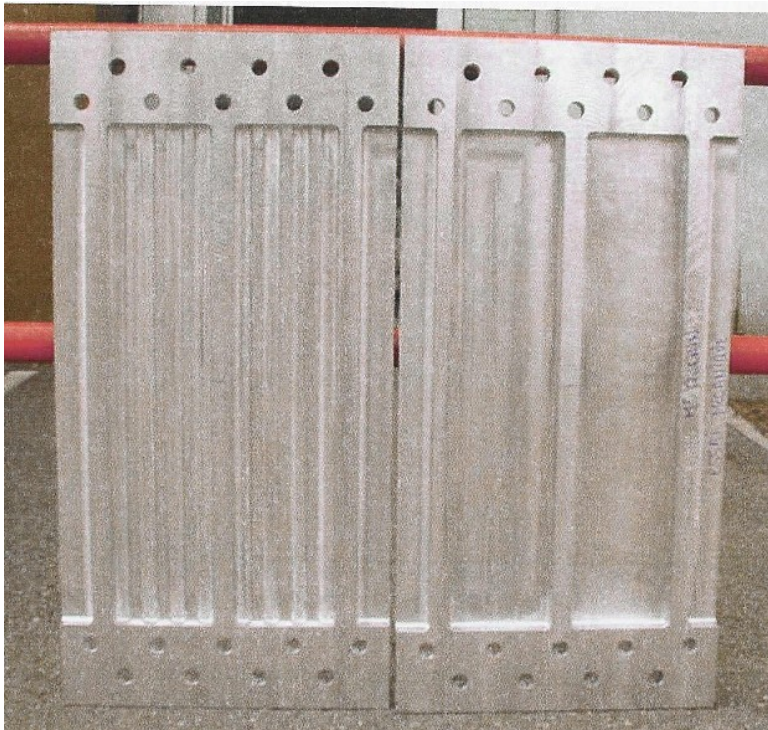

PRODUCT DEVELOPMENT CONFERENCE



Crack retardation : Results

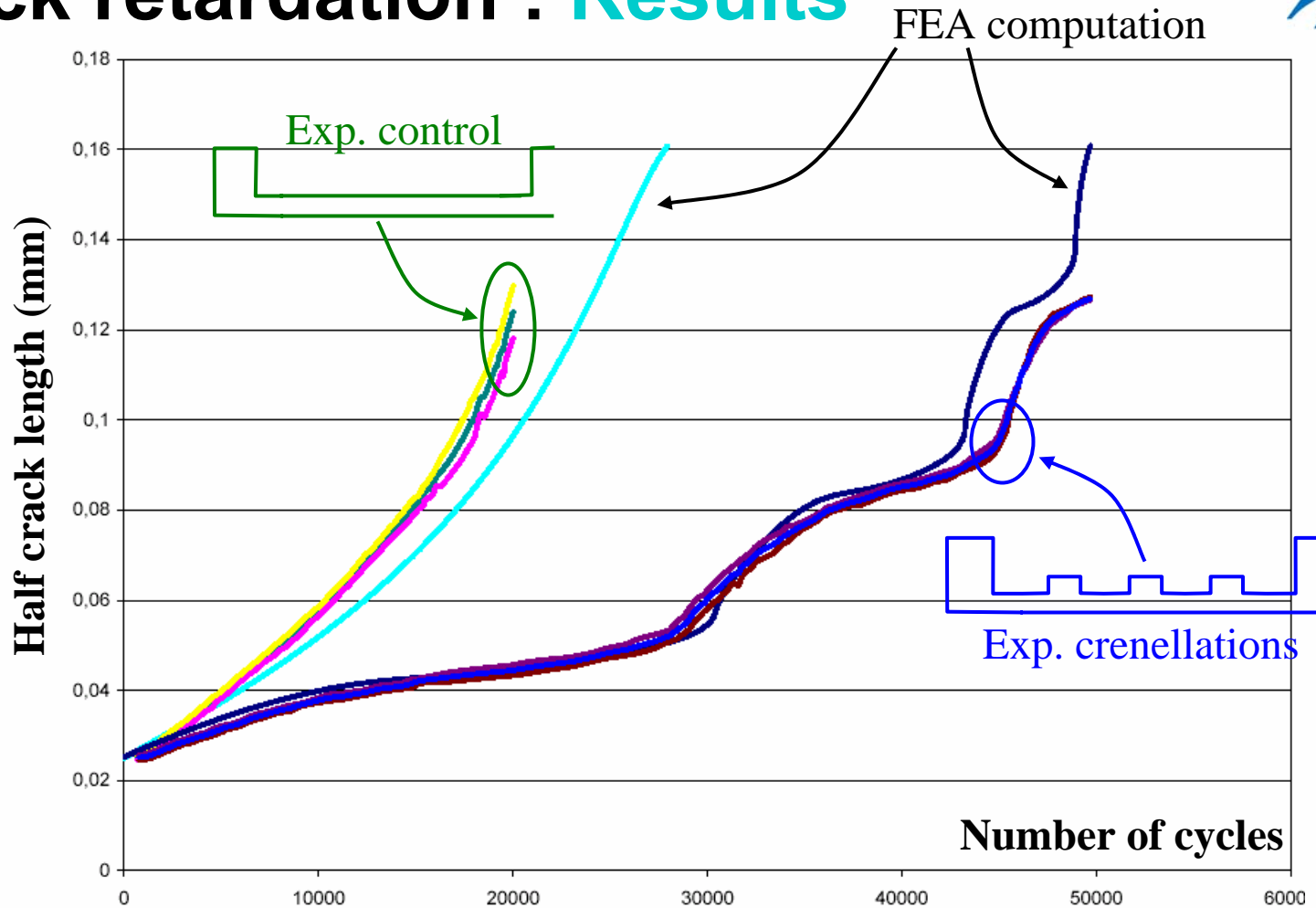

PRODUCT DEVELOPMENT CONFERENCE

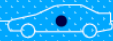

Conclusion



Automated FEA tool for DT design **developed** and **validated**

- Based on MSC.Marc
- User-friendly
- Wing and fuselage panels
- Many features
 - Transverse and longitudinal cracks
 - Complex stiffener geometry
 - Displacement or stress controlled
 - Integral, bonded or built-up structures

Ideal for

- Weight savings evaluation => new alloys
- Innovation => new design concepts, virtual materials

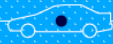

Future work



New features

- Crack running along stiffeners
- Crack between stiffeners (no stiffener broken)
- New mesh refinement method
- T-stress calculation => crack turning