



Combining Test and Analytical Simulation in a Fatigue Process: A Hip Joint Example

Jeff Mentley

nCode International

Presented by:

Mark Pompetzki

nCode International



Hip Model Description

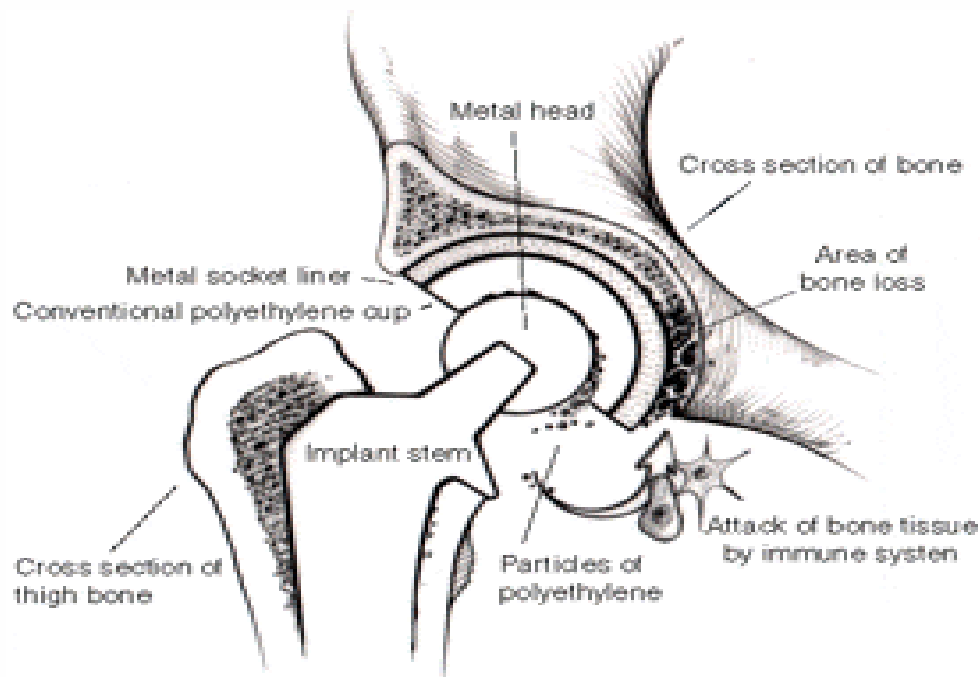

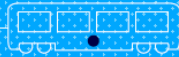

Overview

Failure Modes

Fatigue process

Hip joint example

- Materials
- FE modeling
- Loading

Correlate fatigue model

In patient loading



Failure Modes

Failure Modes

- Failure of the cup
- Fatigue failure of neck
- Resorption of the bone
- Failure of mid section
- Fatigue failure of stem
- Loosening of the implant

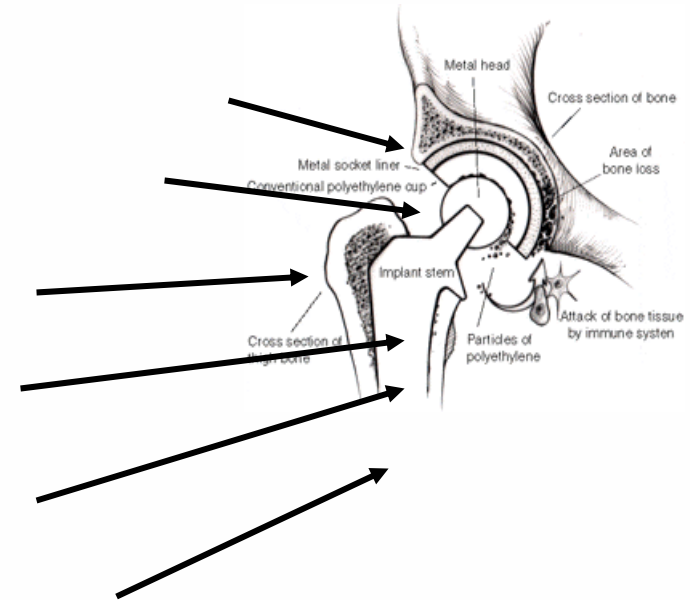

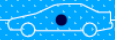

Objective



Investigate the durability process using hip joints as an example

Examine the fatigue life of the hip joint implant under in-patient loading



Fatigue Process

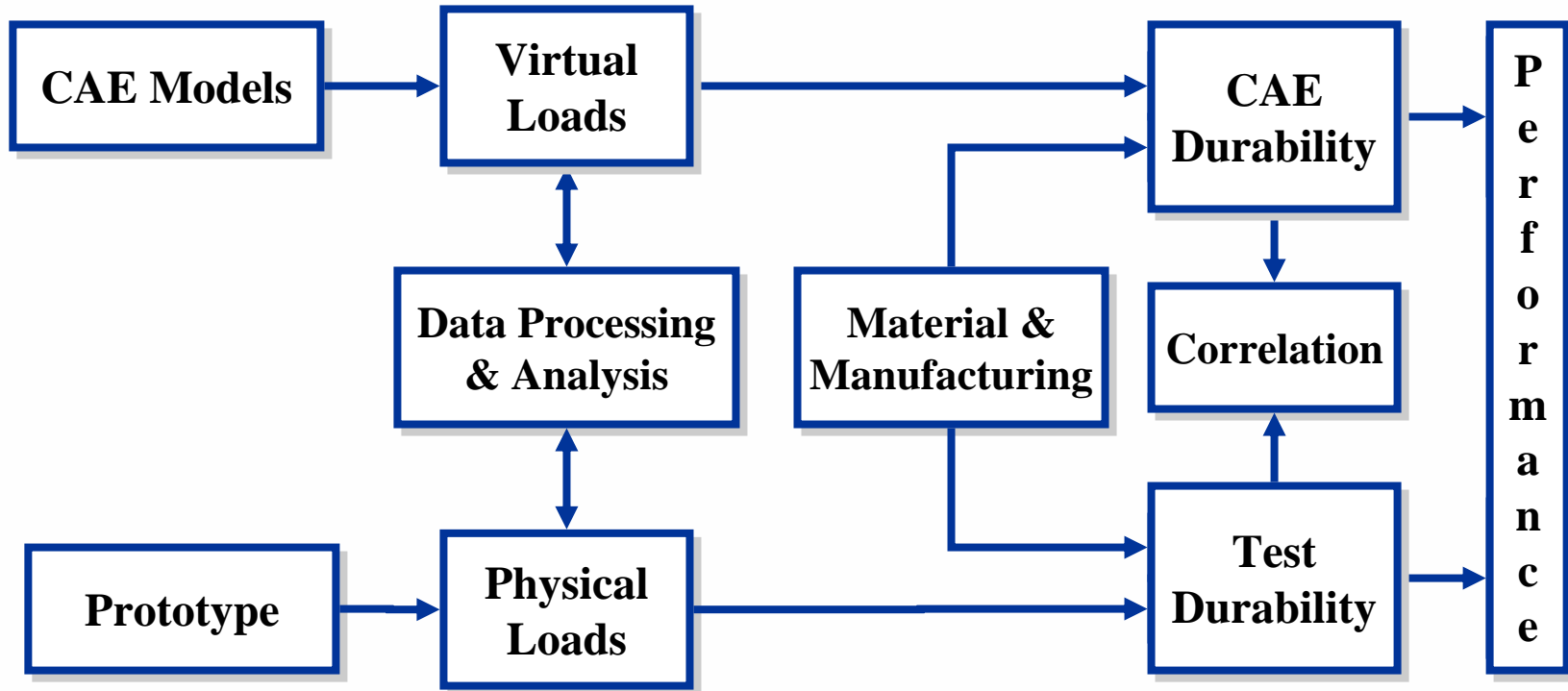



Inputs: Test based Fatigue Analysis

Material – cyclic properties

FE modeling – as loaded in the laboratory

Loading – for lab conditions

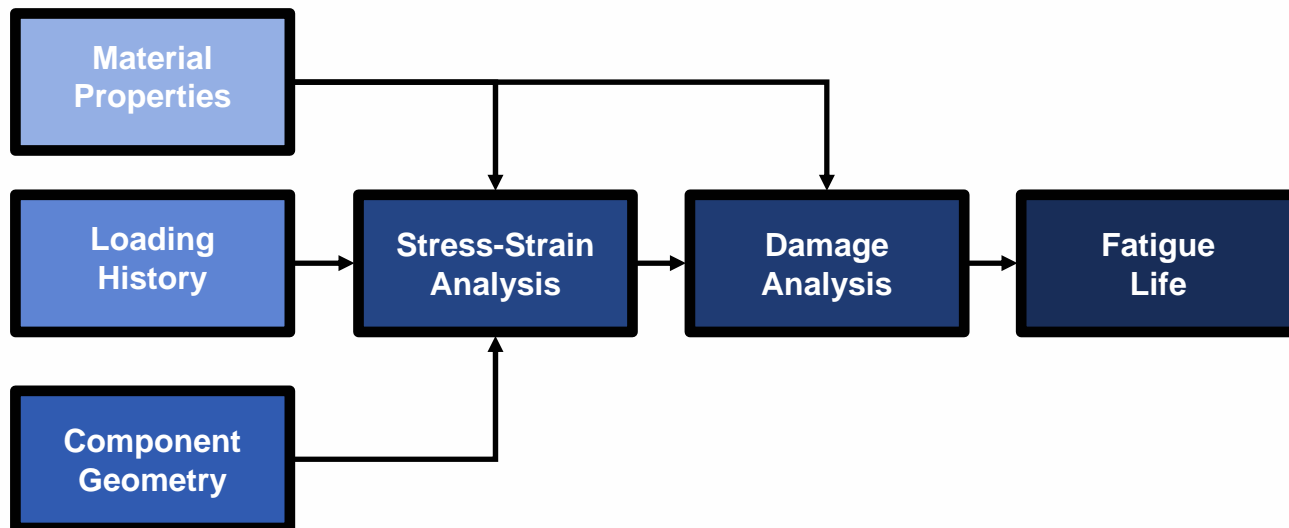

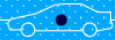

Fatigue Properties

Cyclic properties

- $\epsilon-N_f$
- $\sigma-\epsilon$

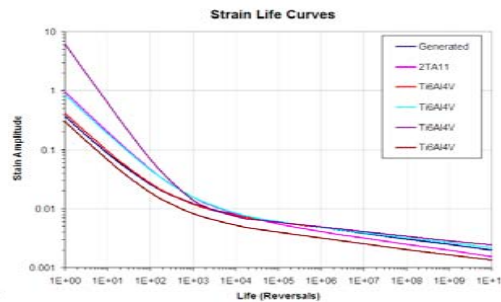
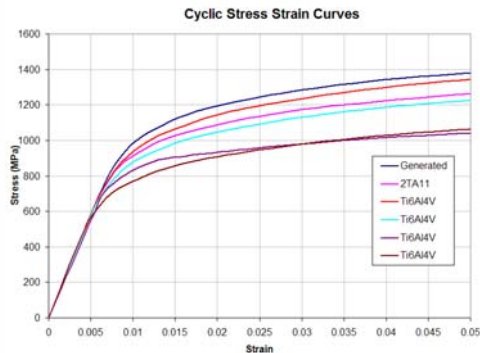

MTS SYSTEMS CORPORATION

FEM Model – Stress Analysis



nCode 
Durability

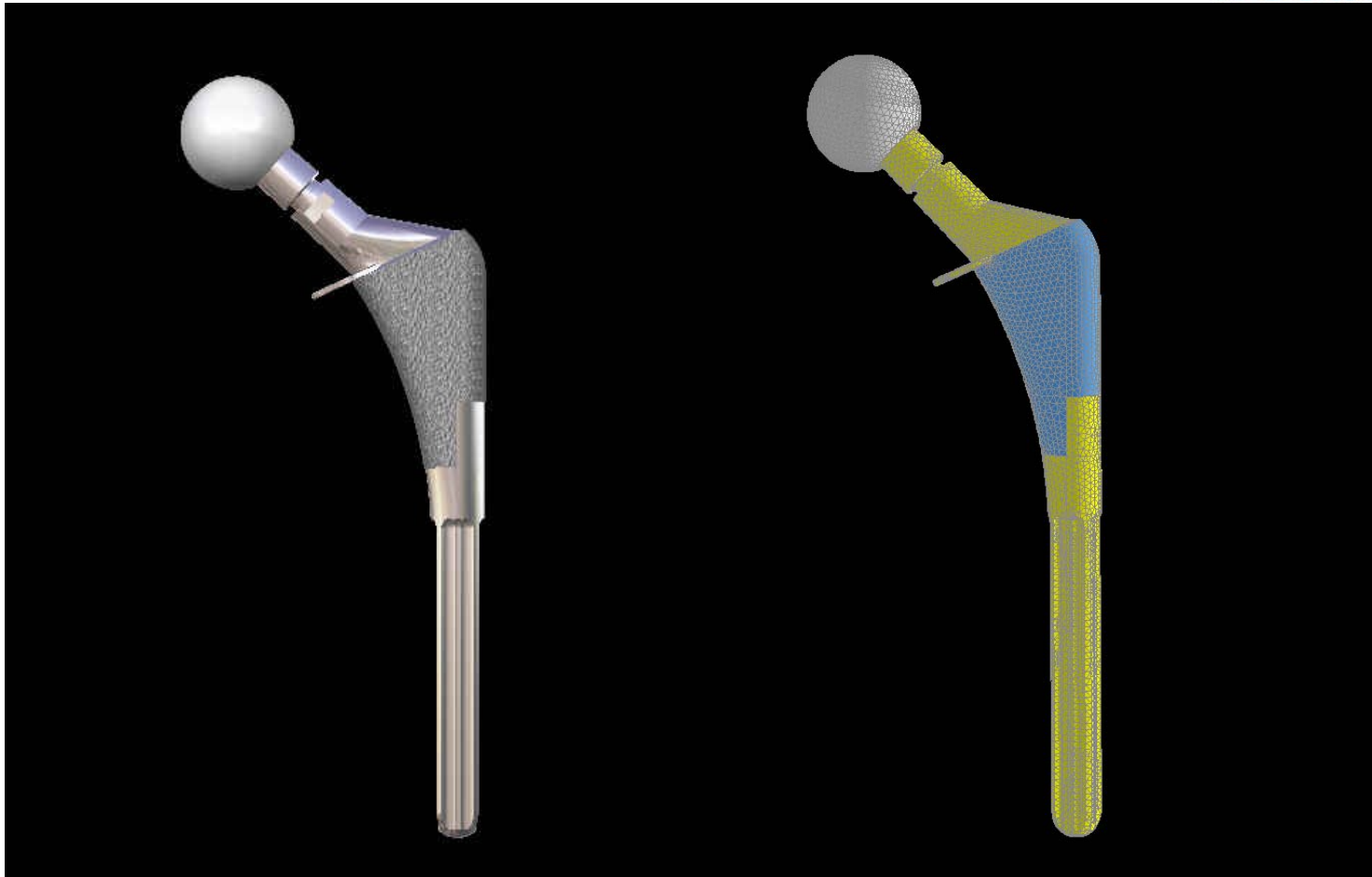

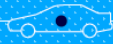

Laboratory Loading



ISO requirement

- Part of FDA approval

Correlate the fatigue model before looking at in-patient loading



Physical Test

ISO 7206 test procedure

- Test geometry
 - Head location
 - Implant orientation
- Potted test fixture
 - Bone cement
 - Epoxy

Loading $R=0$ thru head center



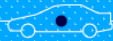

Detailed Stress Analysis

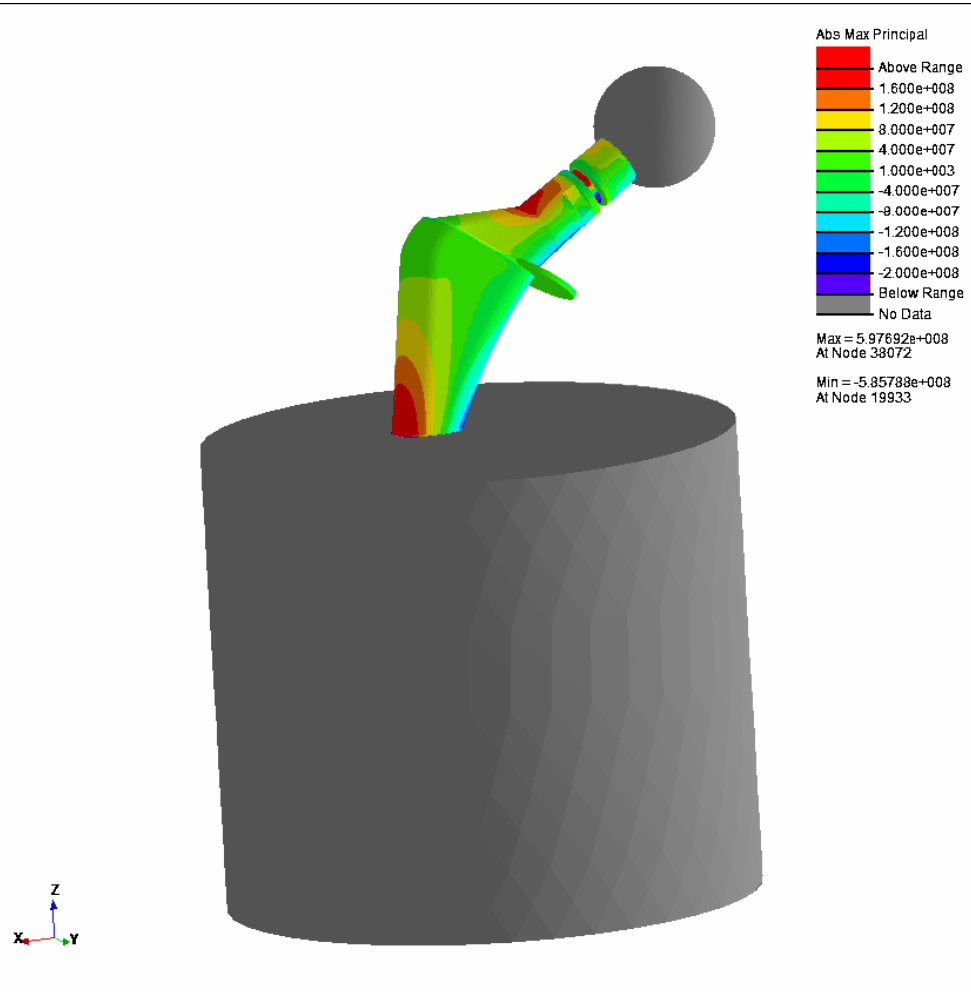

PRODUCT DEVELOPMENT CONFERENCE



Virtual Test

- Reproduce constant amplitude loading
- Fatigue analysis

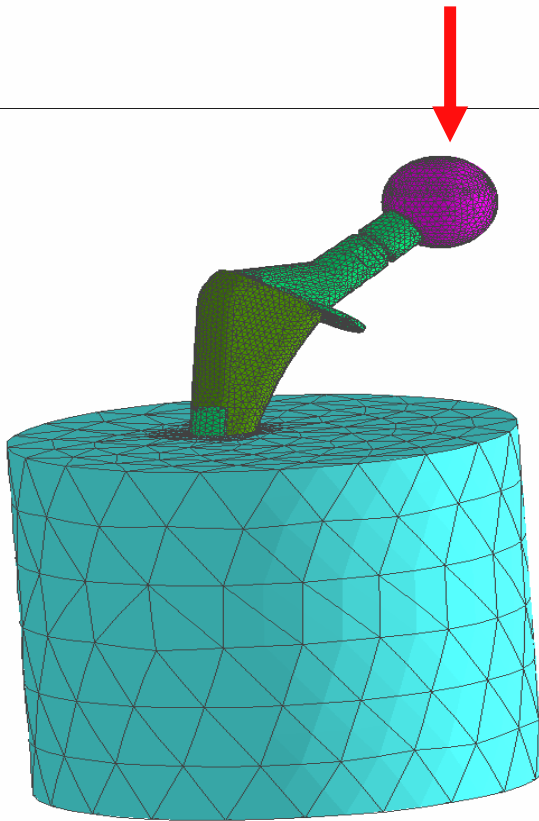

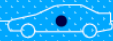

Fatigue Process

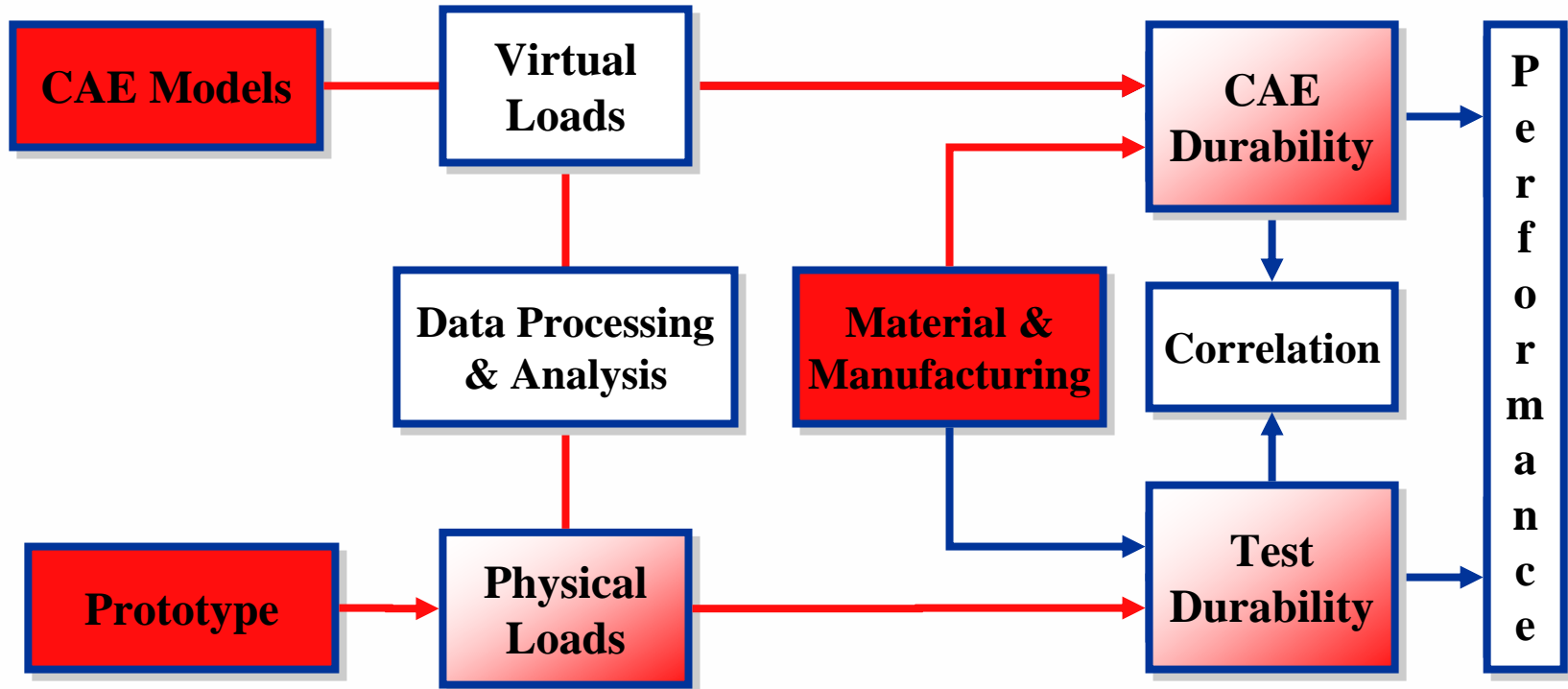



Correlate Fatigue Model



Fatigue Correlation

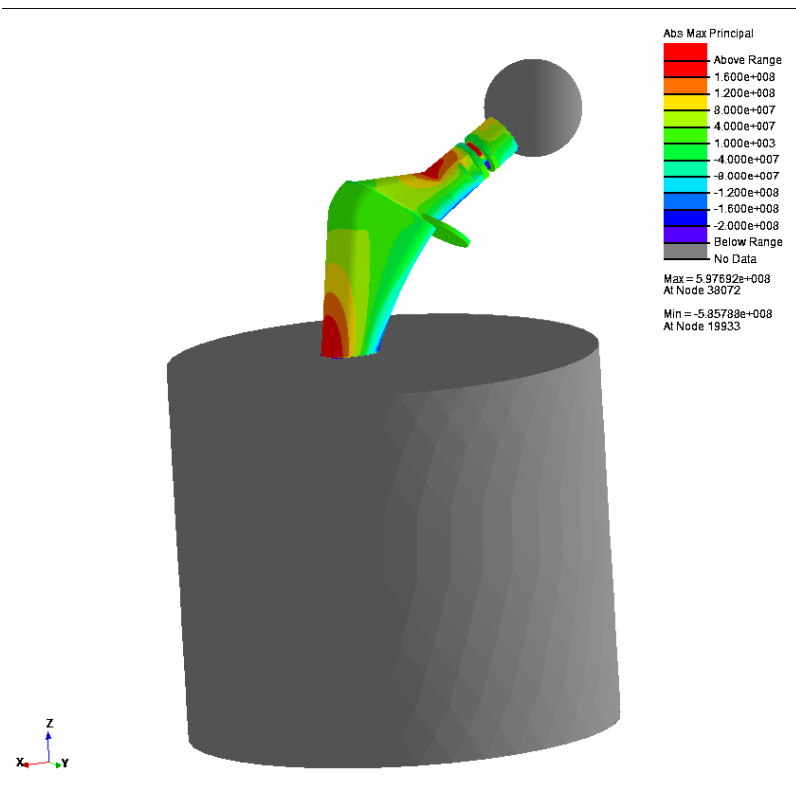

Stresses

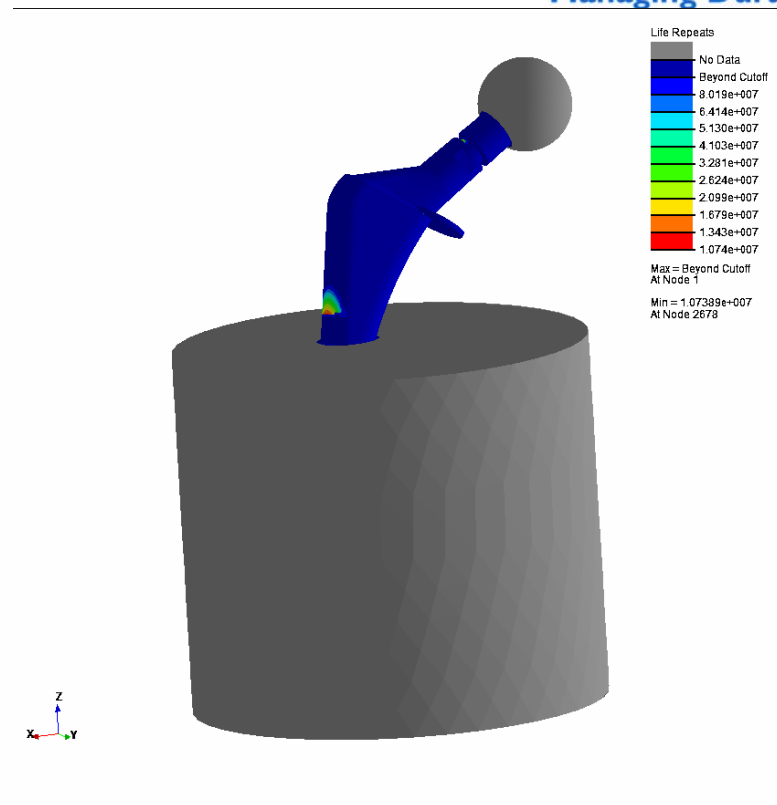

Fatigue life

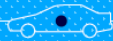

Fatigue Process

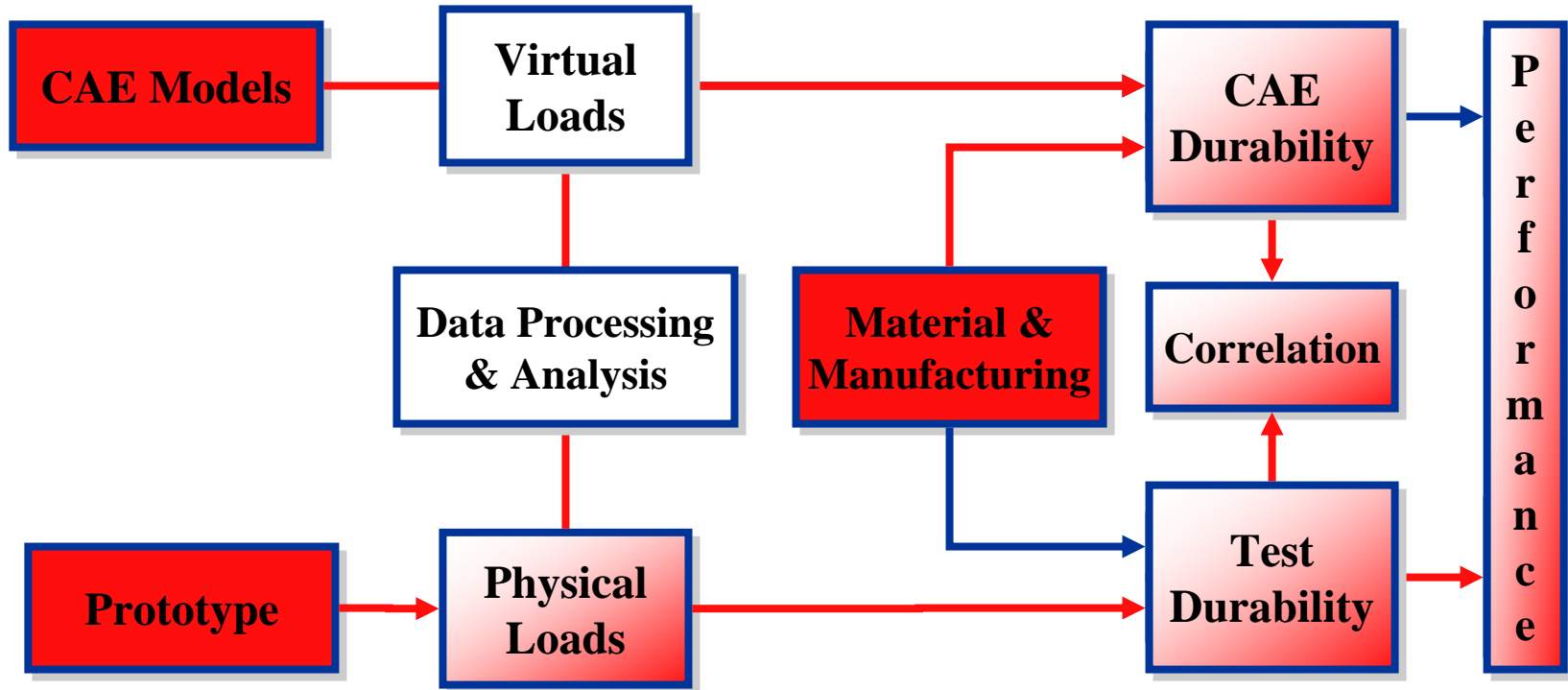



In-Patient Loading

- Femur model
- Measured loads
- Virtual loads
- Duty cycle



Inputs: Fatigue Analysis for In-Patient loading

Material – Unchanged

FE modeling – Model implant and femur

Loading – In-patient loading

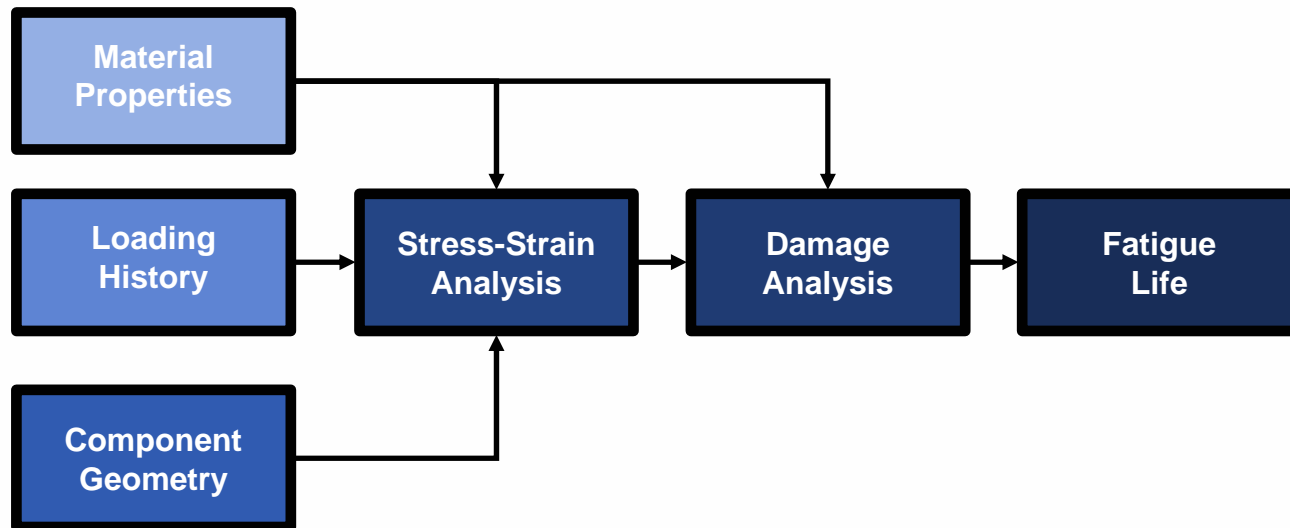

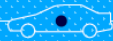

Femur Model

nCode 
Managing Durability

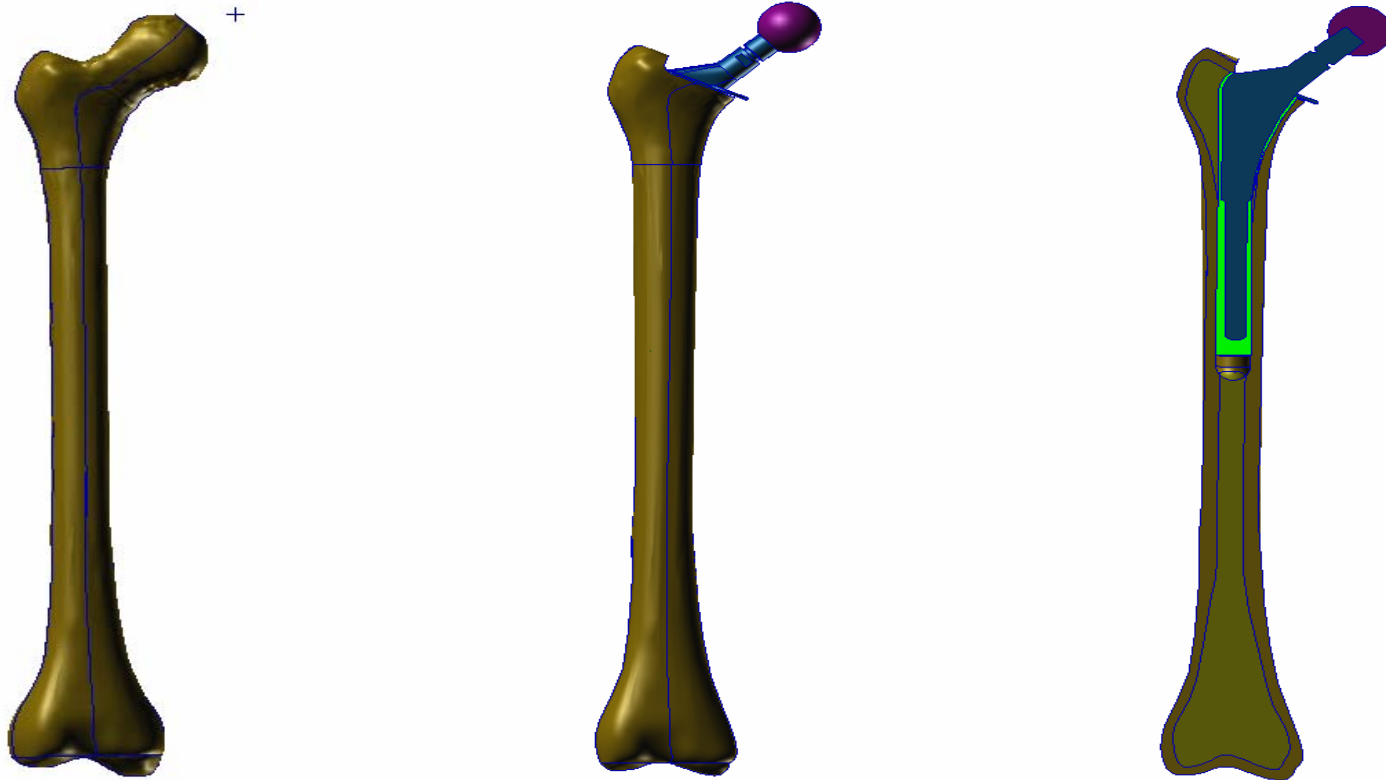

PRODUCT DEVELOPMENT CONFERENCE



Femur Model

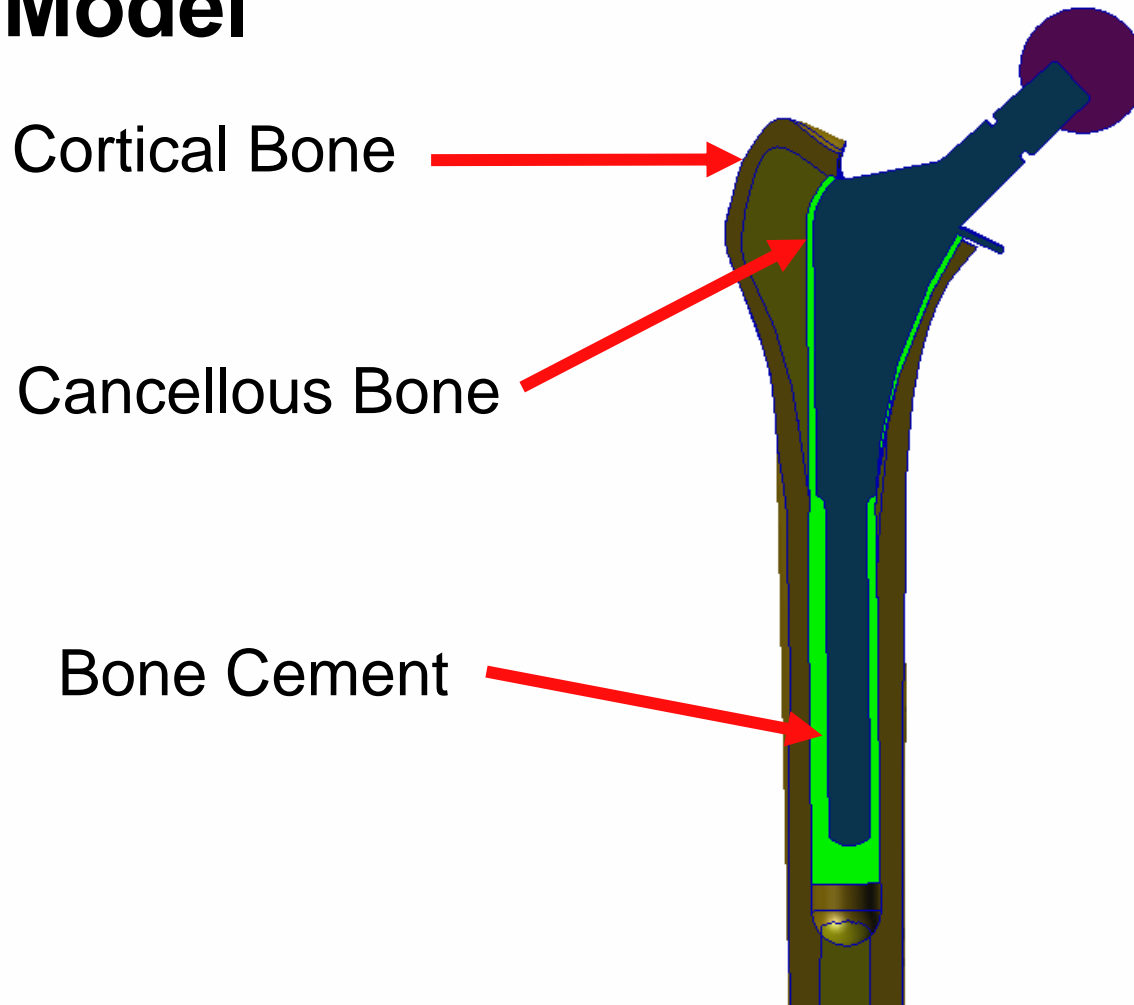

Measured Loads

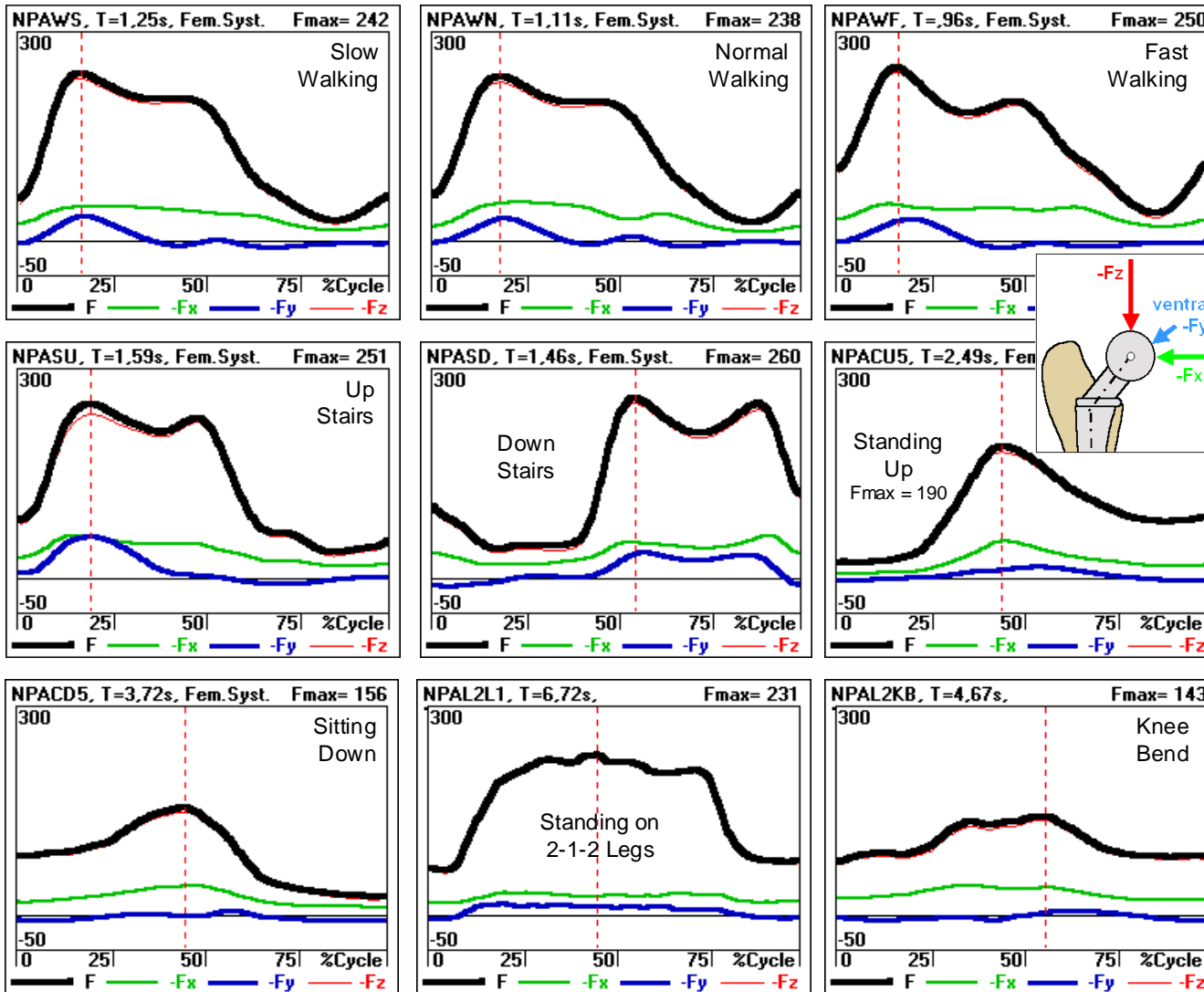

Reference: G. Bergmann, G. Deuretzbacher, M. Heller, F. Graichen, A. Rohlmann, J. Strauss, G. N.Duda., Hip Contact Forces and Gait Patterns from Routine Activities, J. Biomechanics 34 (2001) 859-871.

NT CONFERENCE



LifeMOD

nCode 
Managing Durability





Virtual Loads (LifeMOD & MSC.ADAMS)

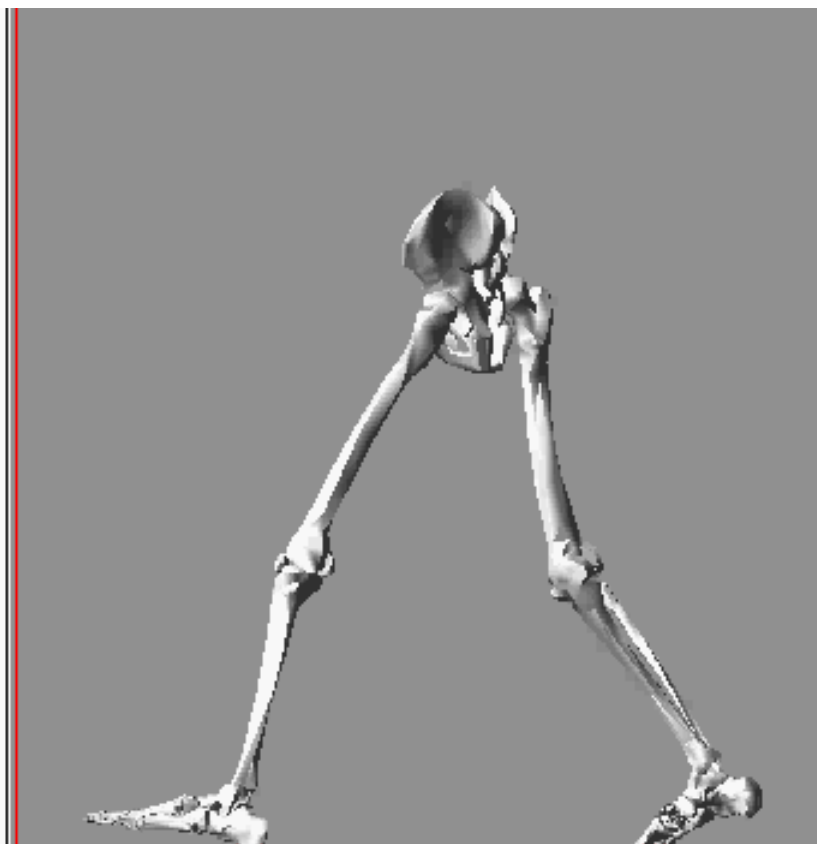
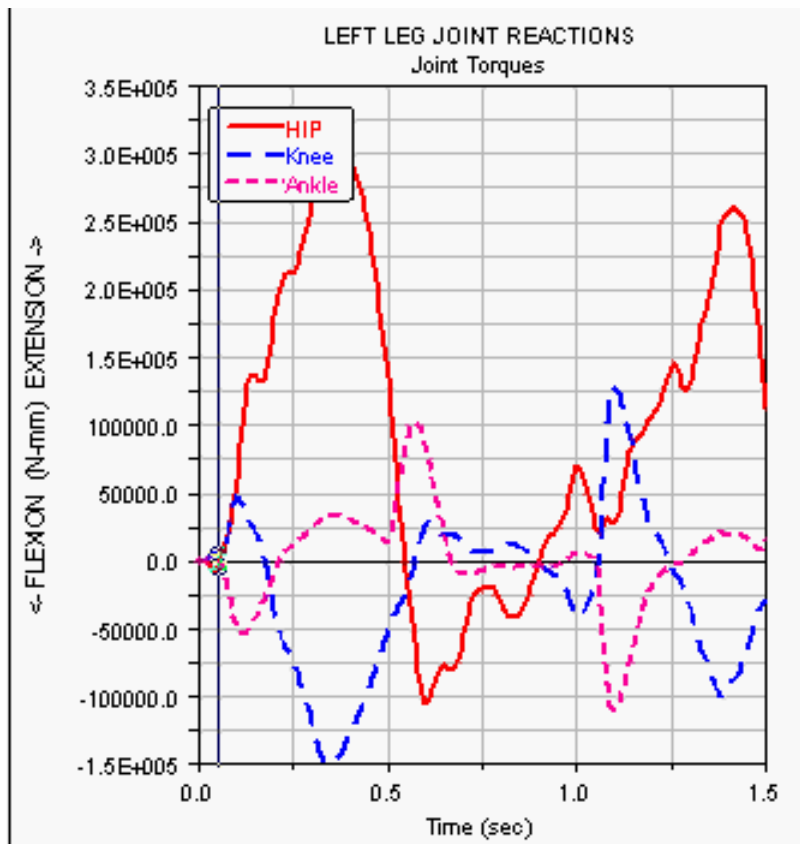

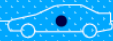

Patient Activity Schedule

Usage in number of events per day

- Activity Percentile

Load histories from LifeMOD

- Patient physical characteristics
 - Height
 - Weight
- Simulation of each event type
 - Walking
 - Stair climbing
 - Sitting

Form Duty Cycle Schedule

Patient Activity



Durations and frequency of most common activities

	Unit	Median	Mean	SD	Min	Max	Median
		Per Year	Per 12 hours				
Walking							
sequences	[#]		351	130	141	637	349
total time	[min]		73.1	38.3	19.8	156.6	72.4
steps	[#]	2.7 million	7691	3890	2400	15152	7503
Stairs Up & Down							
sequences	[#]		42	52	0	185	21
total time	[min]		3.1	2.9	.0	14.4	2.4
Stairs ¹	[#]	42 thousand Stairs Up 42 thousand Stairs Down	344	263	9	896	227
Sitting							
sequences	[#]	20 thousand Sitting Down 20 thousand Standing Up	76	61	22	306	55
total time	[min]		319.1	122.0	67.3	605.8	337.9
Lying							
sequences	[#]		2	5	.0	22	.0
total time	[min]		42.0	66.8	.0	232.3	.0
Standing							
Sequences ²	[#]		754	367	140	2132	739
total time	[min]	64 thousand loading cycles	176.1	107.1	27.4	506.6	174.1

¹ Numbers = steps upstairs + steps downstairs

² Assumption: Shift of body weight from one leg to the other every 30 seconds



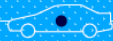

Dutycycle



Duty Cycle Analyser ...femur.fes

File Event Job Options Results Help

Add Edit (Free) Delete Toggle Edit Mode Cancel

Status	Event ID	Event	Type	Name	Extension	Repeats
No results	1	walking	DAC	c1t21_	dac	2700000
No results	2	stairs_up	DAC	c21t22_	dac	42000
No results	3	stairs_down	DAC	c22t23_	dac	42000
No results	4	sitting_down	DAC	c24t25_	dac	20000
No results	5	standing_up	DAC	c26t27_	dac	20000
No results	6	standing	DAC	c28t29_	dac	64000

Calculate Partial ReCalculate Re-Sum Life Abort Job



Fatigue Process

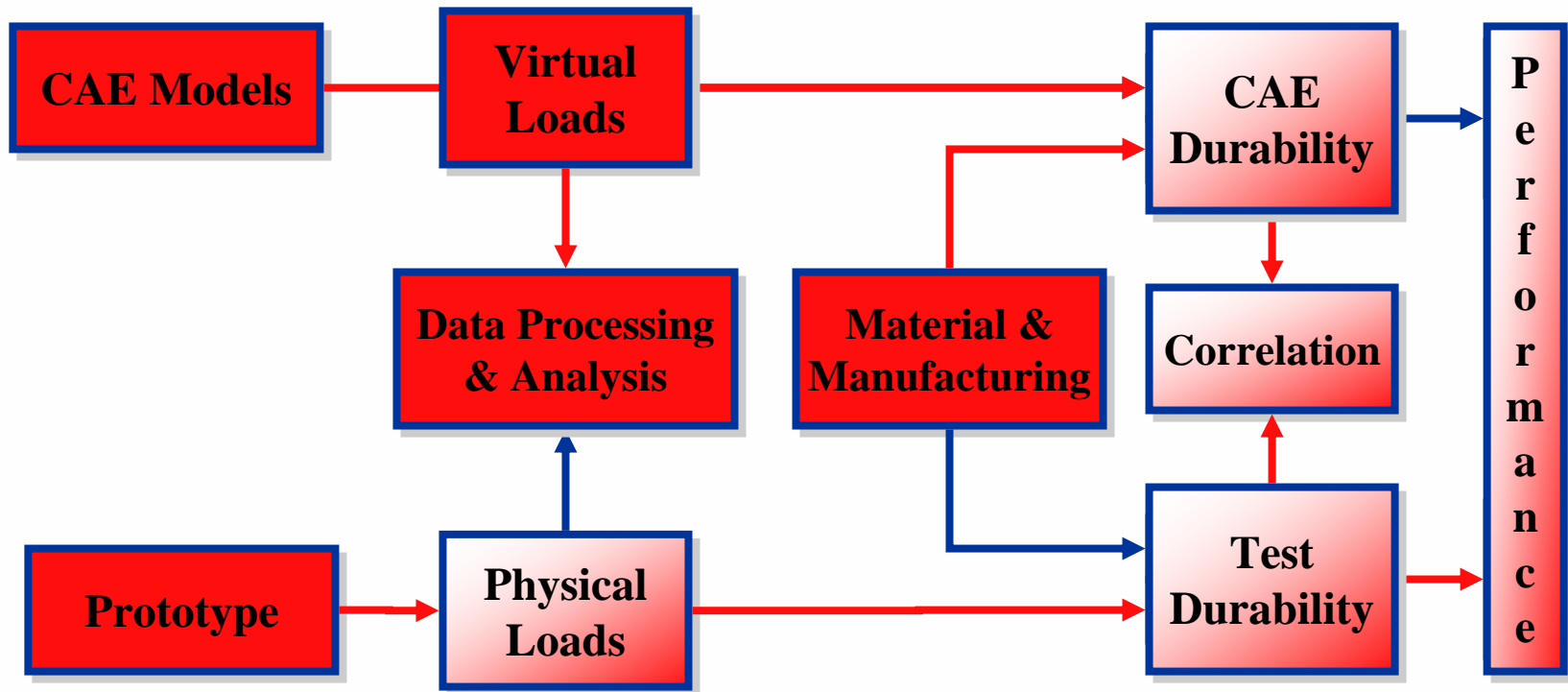



Virtual Fatigue Analysis

Virtual Fatigue Analysis



nCode 
Managing Durability

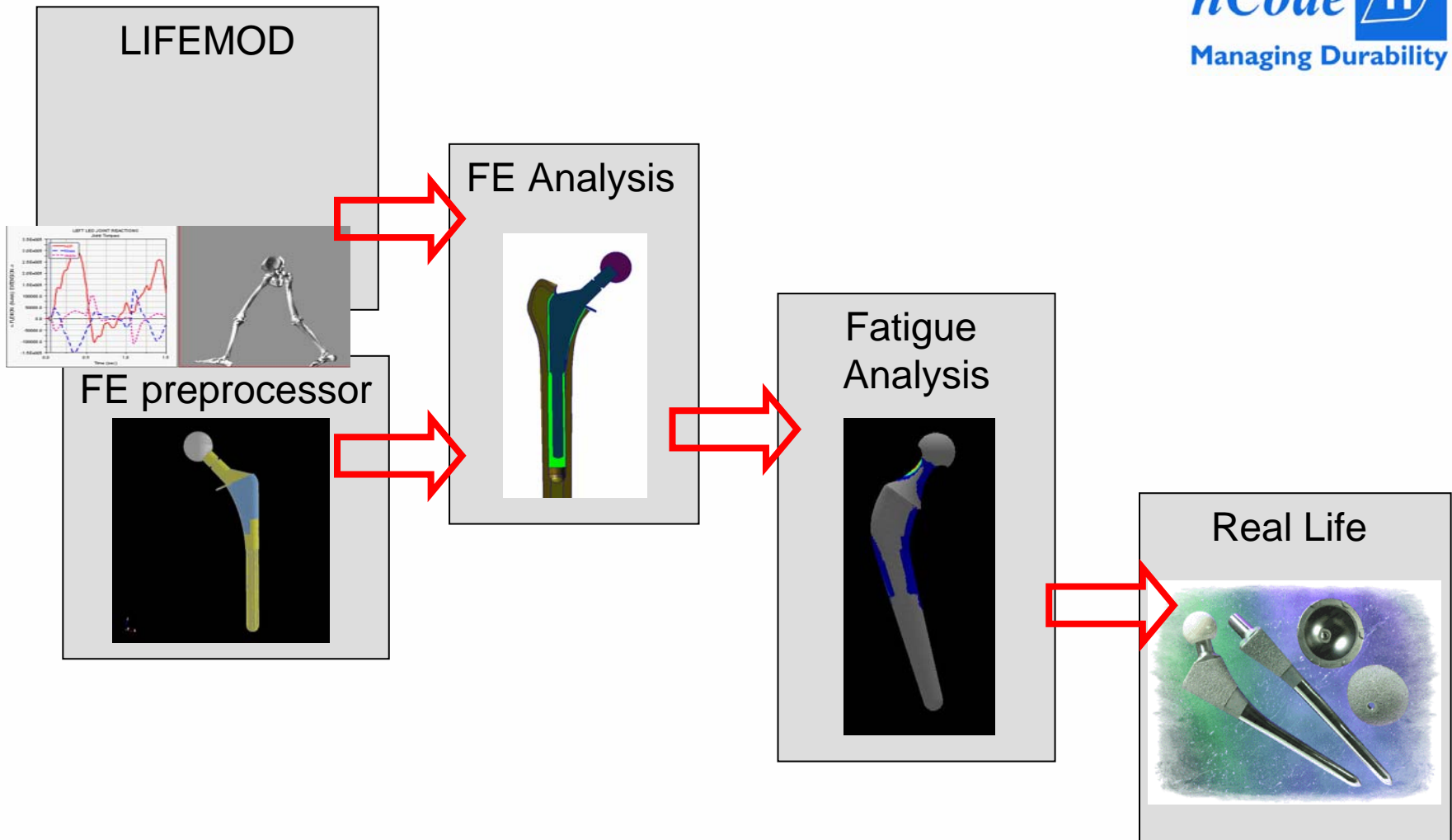

PRODUCT DEVELOPMENT CONFERENCE

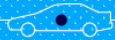

Fatigue Comparison

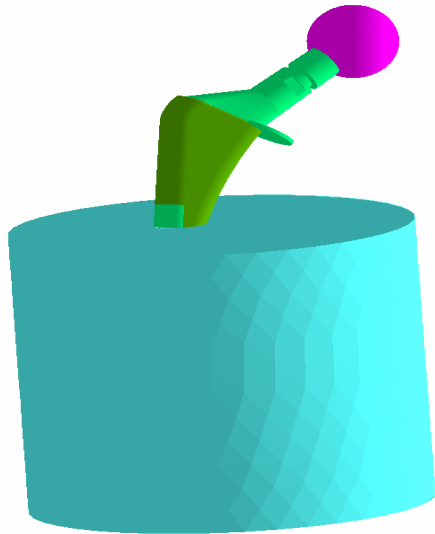

Virtual Test



Virtual In Vivo Loads



Fatigue Process

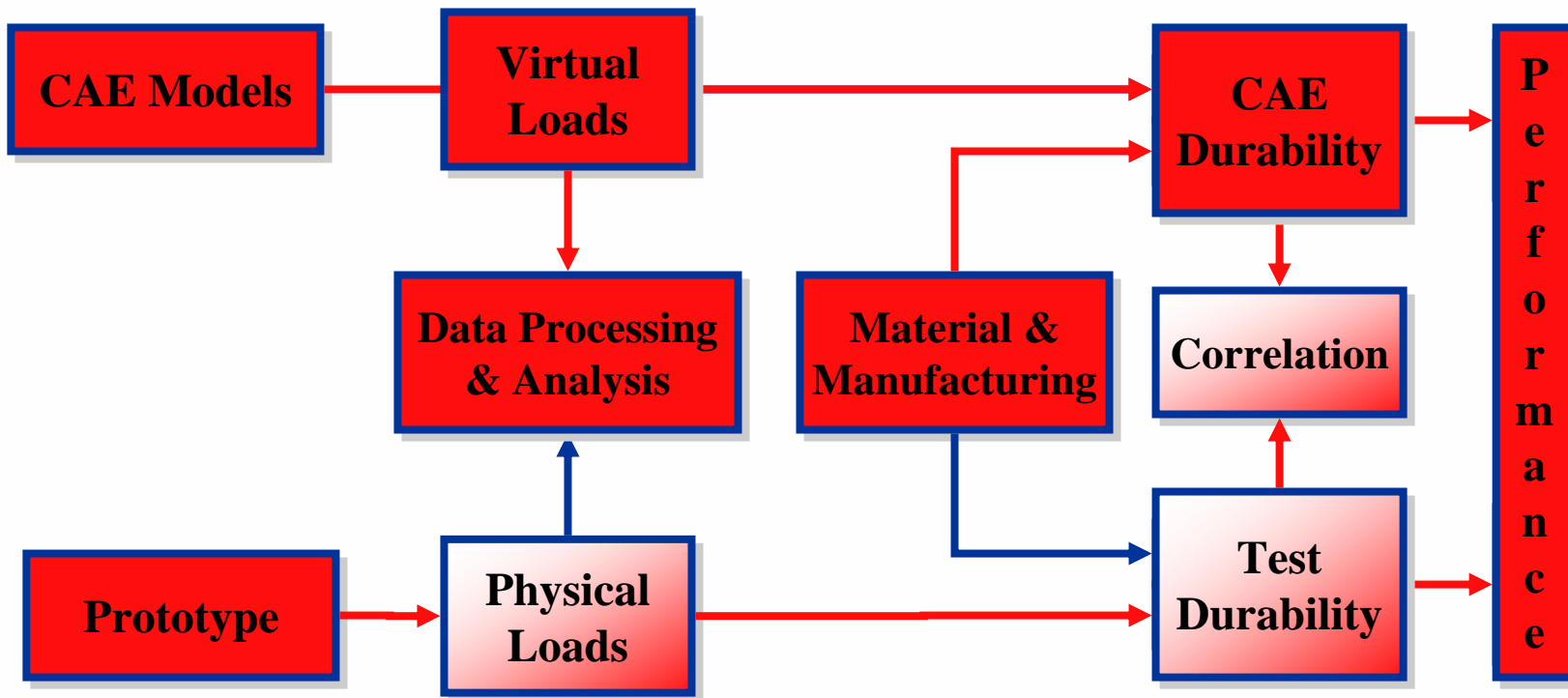

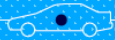

Summary

Neither physical testing or virtual analysis is sufficient by itself

Process to assess durability for in patient loading

Extend methodology for other configurations and loading situations

Evaluate physical tests to develop a more realistic test for longer lives