



Modeling and Simulation of a Subsea Hydraulic Actuator Used in Subsea Oil and Gas Extraction

Joel Tollefson, MSC Software Corporation
Brian Ummel, MSC Software Corporation



Abstract

MSC.EASY5 was used to model the dynamics of a subsea hydraulic control actuator for a leading manufacturer of subsea systems for oil and gas production. This presentation shows how MSC.EASY5 was used to model and simulate the extreme subsea environment and the dynamics of a flexible hose with a hydraulic actuator located 200 meters under the sea and 20 kilometers from the drilling platform.

The presentation also addresses the computational difficulties in modeling transient behavior in extremely long pipes ($> 1\text{km}$), and shows how the Method of Characteristics was used to improve the simulation performance and results.

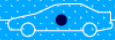

Background

A major supplier of deep sea oil drilling equipment needed to model the dynamics of an undersea hydraulic control actuator.

The MSC.EASY5 Thermal Hydraulic Library was a perfect match for this unique application.





Unique Requirements and Goals

- **Unique actuator requirements**
 - Located >200 meters under the sea surface and 20-50 kilometers from drilling platform
 - Connected to the platform fluid power supply by a long flexible hose.
- **Goals**
 - **Model the effects of viscoelastic hose expansion and contraction as well as depth effects.**
 - **Model and simulate actuator performance and predict stroke timing.**
 - **Evaluate the use of strain energy in the expanded viscoelastic hose and fluid to open a hydraulic cylinder.**

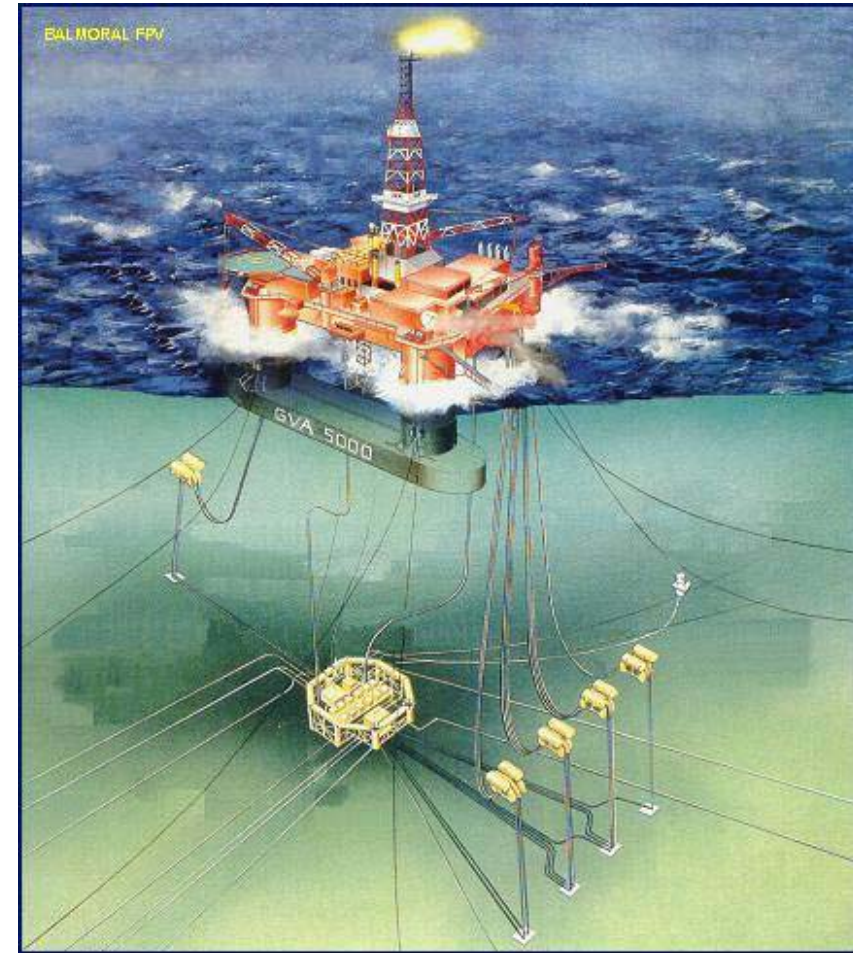



MSC.EASY5 Model

- **Long hose with viscoelastic expansion**
 - **Runs vertically down 230 meters – gravity effects included**
 - **Runs horizontally 20 km**
 - **Elastic expansion time constant= 1sec.**
 - **Viscoelastic expansion time: 30 sec pressurization; 400 secs. depressurization**
 - **Working fluid: SAE10W with some entrained air**
- **Sub sea actuator**
 - **Single-chambered actuator with a moving housing**
 - **Environmental (sea bed) pressure of 20 bar**
 - **Includes both stiction and friction effects**



MSC.EASY5 Model Schematic

Subsea Hydraulic Actuator Model

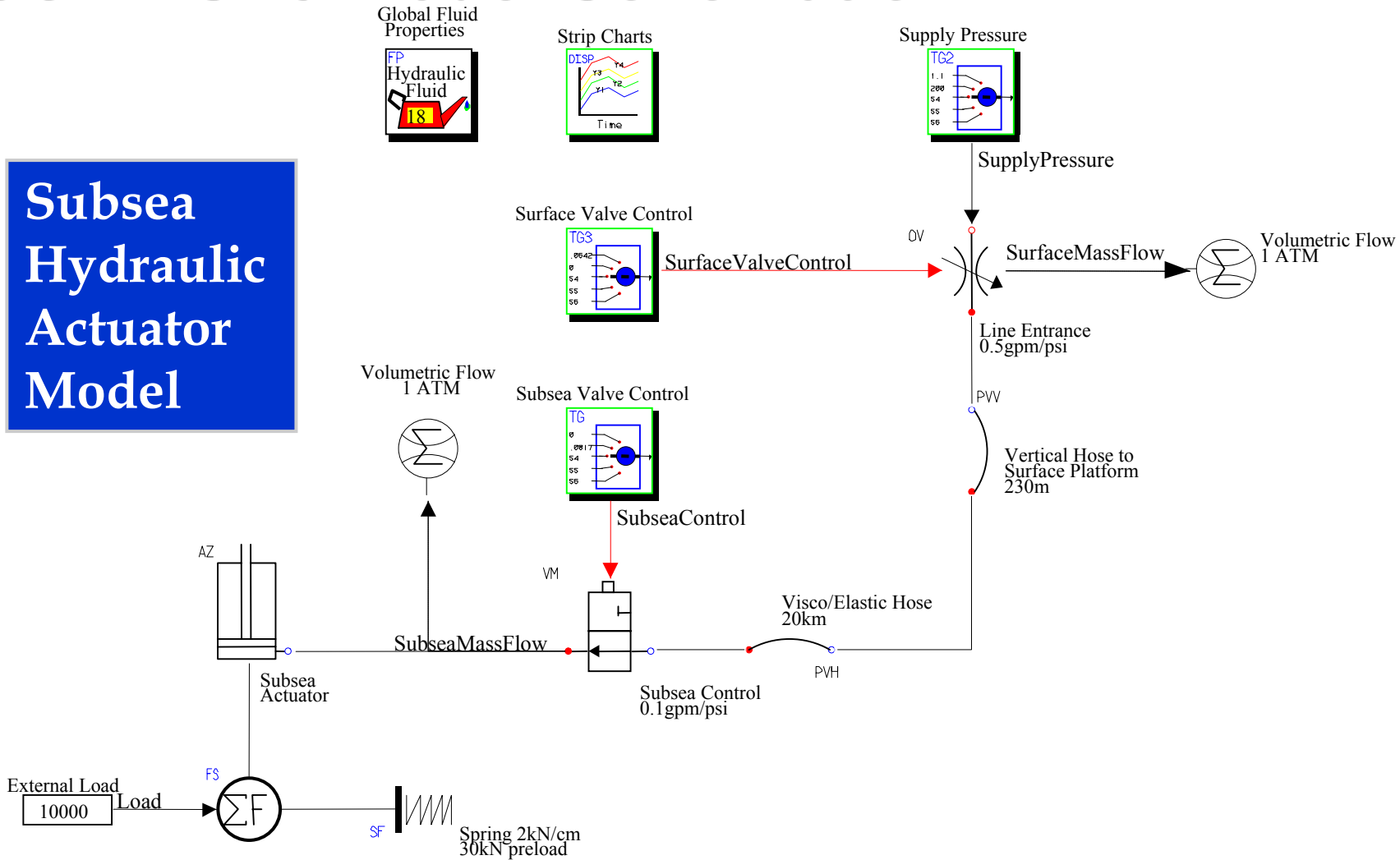

PRODUCT DEVELOPMENT CONFERENCE



3 Test Scenarios

- **Scenario 1 – Charge (pressurize) system**
 - Close subset valve, open surface valve and pump in fluid
 - How long does it take to charge the system?
- **Scenario 2 – Activate system using hose strain energy**
 - First charge (fill) the hose until hose expands (bulges) and acts as an accumulator
 - Shut-off and seal pump at surface and open subset valve
 - Is there enough energy to activate the actuator? How long does it take?
- **Scenario 3 – Vent down (depressurize) system**
 - Shut off pump
 - Divert flow to drain and depressurize line from surface
 - How long will it take to depressurize the system?

PRODUCT DEVELOPMENT CONFERENCE



Simulation Results

- Plot valve positions, pressure, and watch how the pressures, fluid volumes, and actuator positions change.
- Predict how long it takes to charge and discharge the system (hours)
- Plot on right shows actuator pressures for 2 scenarios:
 - 1- charging the system;
 - 2- activating the actuators using the hose strain energy

Pressures in Actuator for Charged Case

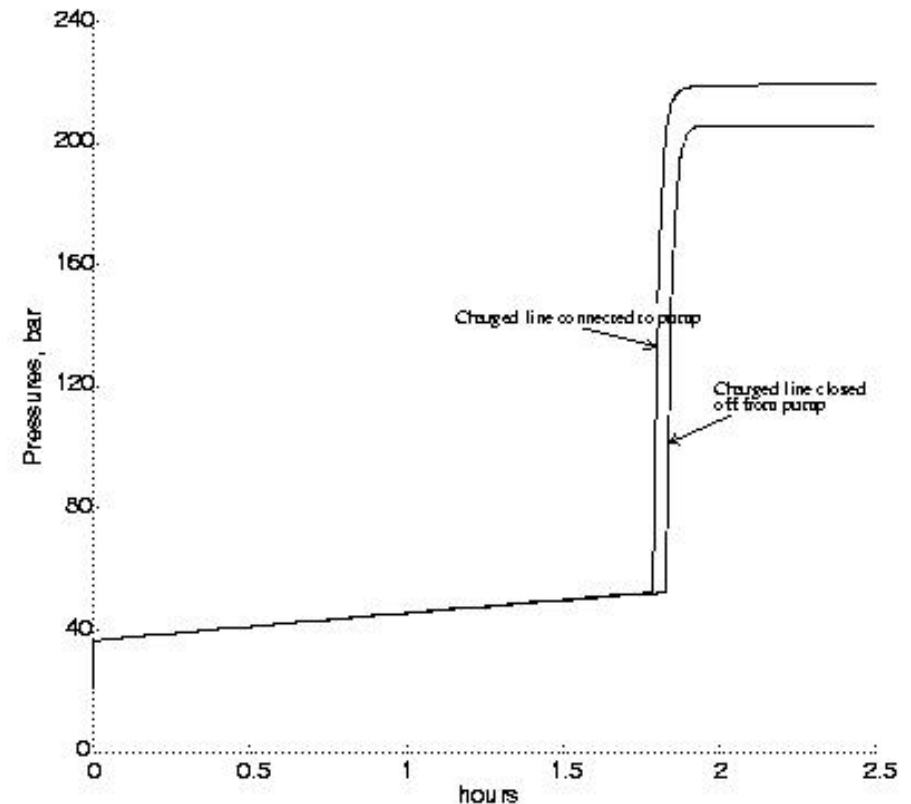



Other Considerations

- **Deep sea oil drilling typically uses long hydraulic pipes.**
- **Problem: transient water hammer.**
- **MSC.EASY5 provides tools to model and analyze water hammer dynamics, and to mitigate water hammer using accumulators.**
- **Typical application: short pipes/hoses in fuel injectors, airplane hydraulic systems, etc.**
- **PROBLEM: method is not well suited for long pipes.**

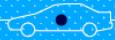

Numerical Method – Lumped Mass

Approach 1 (Lumped Line Model Approach):

- Divide a line into many sections (nodes), each of which can be assumed to have a uniform pressure within it.
- Use continuity equation to calculate rate of change of pressure within each section
- Use momentum equation to calculate the rate of change of flow from one section to the next section.
- This approach results in solution of ordinary differential equations and is the approach used in the Hydraulic Library.

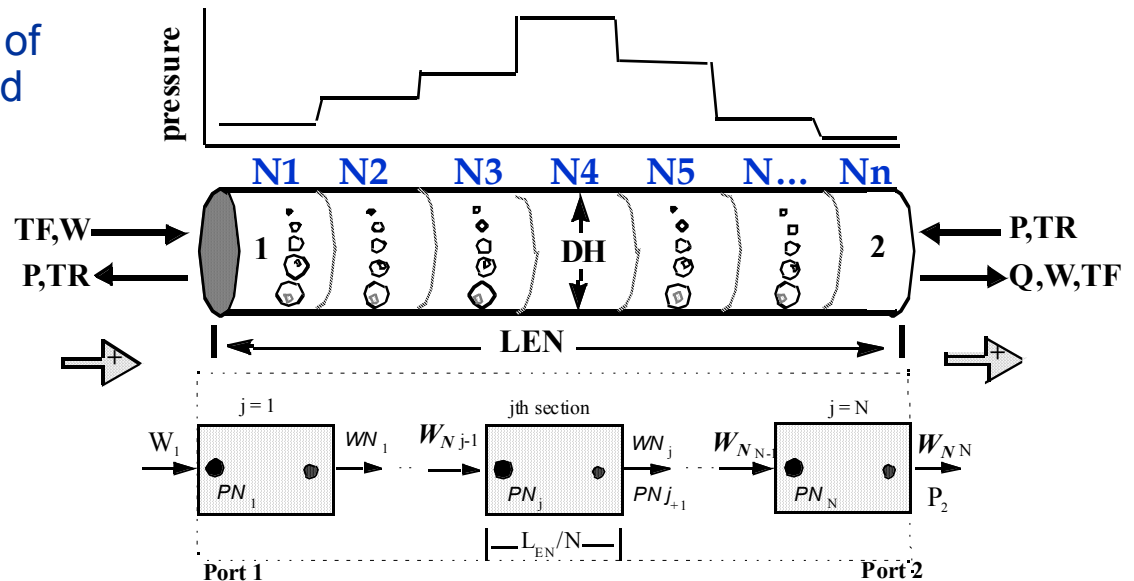

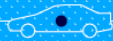

Water Hammer Dynamics

- Special transient pipe component models water hammer and cavitation
- 10 meter pipe could be segmented into 10 nodes (1 m per node)
- Results= 51 states
 - 1 temp
 - 10 pressure, 10 flow rate, 30 friction states
- 1 km pipe= 5,100 states!!
- **Impossible to realistically simulate this!!**

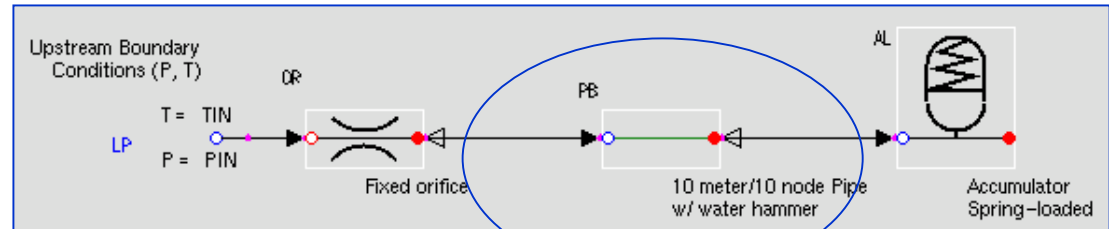

PB2 - Component Data Table (CDT)

Component hc/PB2 10-section Pipe (P)(bubble tracking) Default Tab

Configuration Inputs States Variables Documentation

State Name	IC Value	Description	Units	Error	Frozen	Type
Ported States						
TF_Out_PB2	50.0	Exit fluid temp, Port 2	C (F)	1.0E-6	No	Continu
Primary States						
POV_PB2	(10) Vector	Section pressure or bubble volume	bar(psia)/cm3(in3)			
WNN_PB2	(10) Vector	Section mass flow rates	kg/m (lbm/m)			
XX1_PB2	(10) Vector	Freq-dependent friction state				
XX2_PB2	(10) Vector	Freq-dependent friction state				
XX3_PB2	(10) Vector	Freq-dependent friction state				
Switch States						

Info



Numerical Method – Method of Characteristics

Approach 2 (Continuous Line Model Approach)

- Work directly with the continuous line model which represents the continuity and the momentum equations as partial differential equations.
- Use Method of Characteristics for solving partial differential equations
- By using appropriate time delays, method provides better results than the lumped line model (>10x faster, and more accurate)

Advantage: Requires less states; 1 km pipe= 32 states!



Characteristic Line Method

Goal: calculate variables (P and v) at current node S .

- Node N is the node S at previous time
- Nodes M and O are boundary nodes.
- A continuous time delay or a carousel table can be used to save node data from past time.
- Given known values at nodes M , N , and O , interpolate to node r and z , and use this to calculate values at node S .

2 eqs. And 2 unknowns (P_s, v_s):

$$(\rho c)_r (v_s - v_r) + (P_s - P_r) = \left[\frac{c^2 R_{12} + c R_3}{\rho C_p} \right]_r \Delta t$$

$$(\rho c)_z (v_s - v_z) + (P_s - P_z) = \left[\frac{c^2 R_{12} + c R_3}{\rho C_p} \right]_z \Delta t$$

Where:

- c = velocity of sound in fluid
- C_p = Specific heat
- ρ = density
- R_{12}, R_3 = shear force and heat transfer factors

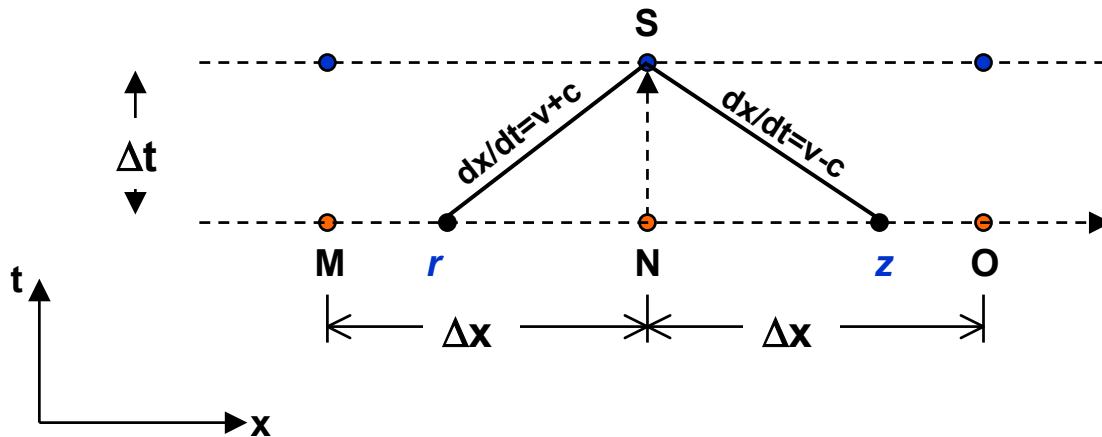



Long-Pipe Hydrodynamic Simulation

- Deep sea scenario:
 - Up to 50 miles long pipes with actuator/valve at end
 - Purpose: pump NT3 fluid into hydraulic control system used to actuate a valve attached to flow line to control flow of gases/crude oil

- Studies:

- Transient pressure in system
- Response time to close and open actuator
- Effect of long pipes, & temperature on system performance

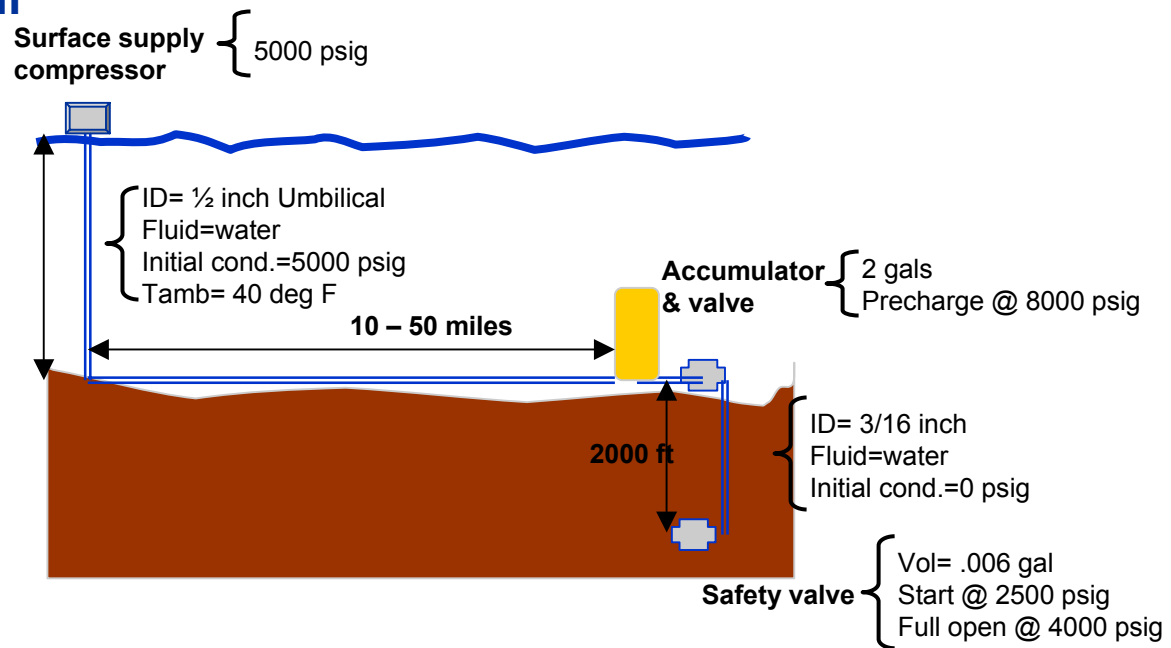



MSC.EASY5 Model with Long Pipe Dynamics

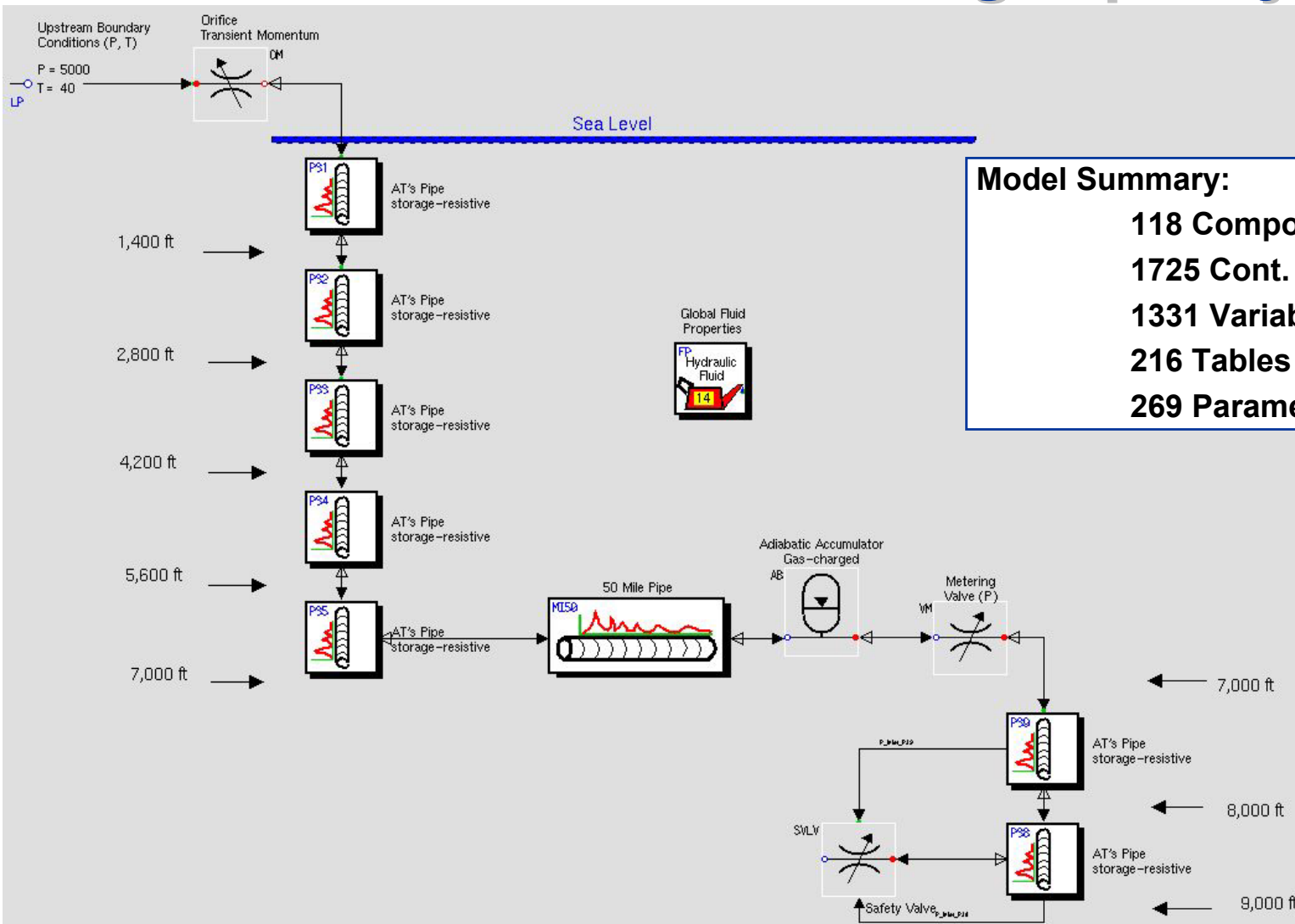

Model Summary:

118 Components
1725 Cont. States
1331 Variables
216 Tables
269 Parameters



Summary

- MSC.EASY5 ideal CAE tool for modeling subsea hydraulic systems
- Requirement to simulate water hammer dynamics in long pipes results in large models with unacceptable number of states
- Method of characteristics used to simulate water hammer; reduced # states by factor of 160
- New and improved Method of Characteristics being developed to improve accuracy and performance – can be applied to both gases and fluids