

MSC.Software VPD Conference | July 17-19, 2006 | Huntington Beach, California

# The Utilization of MSC Easy5™ to Conduct Thermal Analysis of an Aircraft Fuel System

Jonathan Jobe  
System Dynamics Engineer, Gulfstream Aerospace

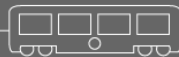

# Problem Scenario

- **Gulfstream G550**

- Extended range flight 6750 nm
- Flight times at altitude anywhere from 12-14 hours
- 51000 ft cruise temps measured as low as  $-85^{\circ}\text{C}$  (ISA  $- 30^{\circ}\text{C}$ )
- Fuel contributes 40900 lb of max takeoff 91000 lb

- **Fuel System analysis over flight profile**

- Probe measurement error compensation
- Performance benefits

# System Description

- Fuel Tanks
- Pumping Stations
- Engine Fuel-Cooled Oil Cooler
- Heated Fuel Return System

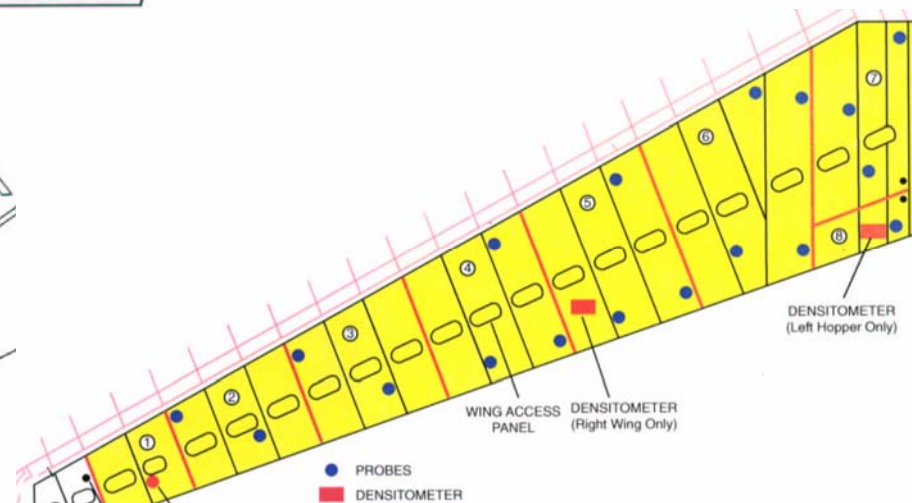
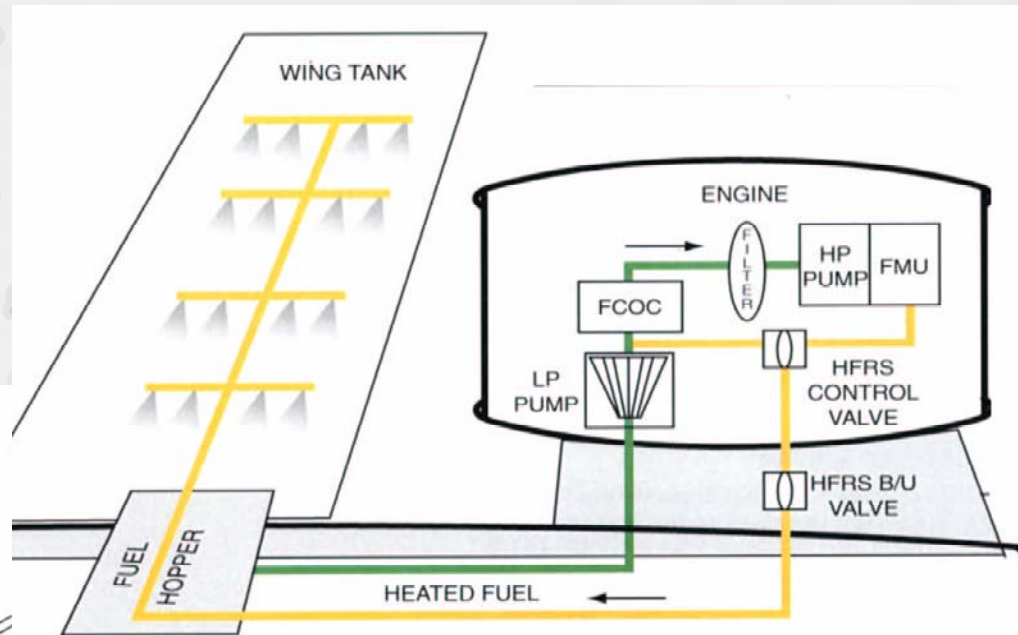
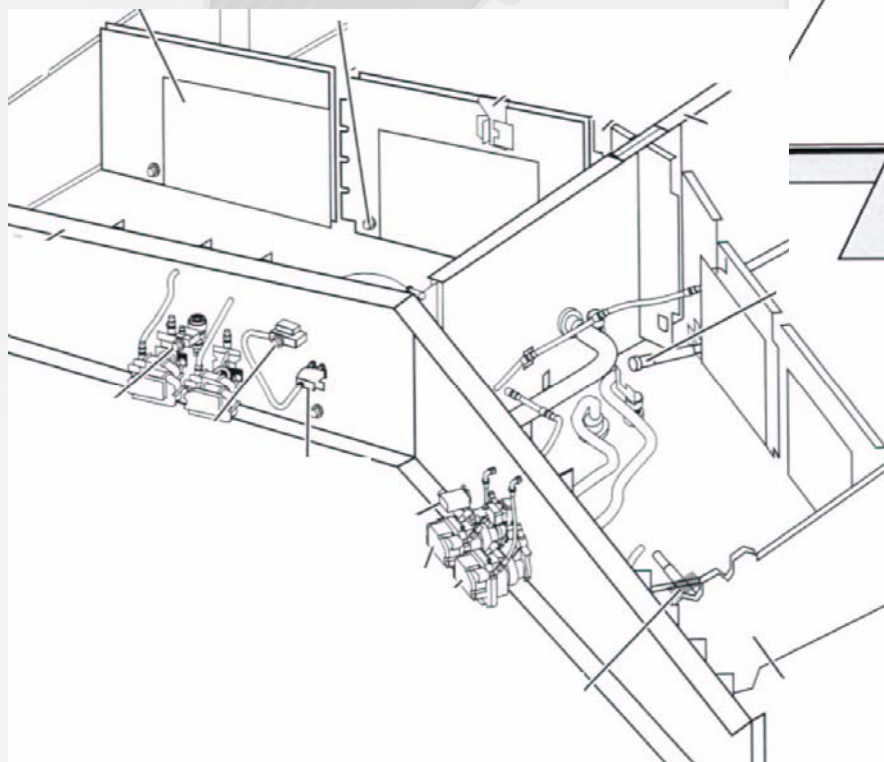

# Modeling Effort

- **Model level of accuracy**
  - Transient state changes of interest occur on the order of minutes
- **Submodels**
  - ***Flight Profile***
    - Drives pumping system and engine consumption
    - Aero equations and engine performance maps drive fuel requirements from flight profile with G550 aero calibrations
    - Drives fuel migration as a function of aircraft attitude in wing fuel bay blocks
  - ***Pump & Engine Return***
    - Fuel Boost Pump drives fuel from wing bays to engines
    - Fuel-Cooled Oil Cooler (FCOC) bypass valve performance map drives heated fuel return system as function of engine fuel burn rate
  - ***Heated Fuel Return System (HFRS)***
    - Drives return fuel flows to individual bay blocks in Wing submodel
    - Future: Drives a CFD model to drive wing bay convection coefficients
  - ***Wing***
    - Fuel Bay block created to simulate fuel temperatures
    - Blocks connect to build wing fuel storage

# Flight Profile Submodel



- User input for any desired profile
  - Time, Altitude, Speed, Auto-throttle, Aircraft attitude, Temp (ISA + bias)
  - Custom Thrust Block develops correct usable flight profile based on union of airframe, thrust capabilities, & regulations
  - Custom Fuel Block generates fuel usage requirement from engine fuel maps
  - Almost 40 surface calibration maps implemented easily with MSC.Easy5™

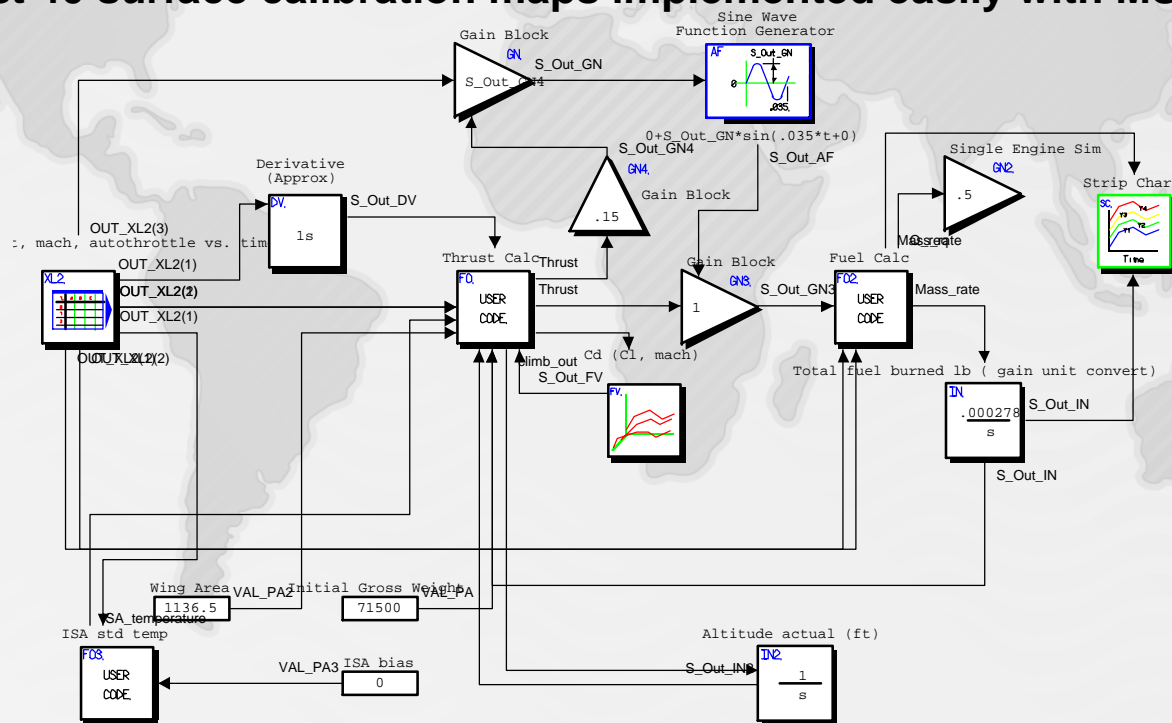

# Pump & Engine Return Submodel

- Pump flows driven by PID controller to satisfy Engine & HFRS requirements
- Contains *Pump submodel* to govern pump performance
- HFRS flow driven by fuel heater bypass valve performance map and PI controller, used to drive *HFRS submodel*
- Engine flow driven by *Flight Profile submodel* and PI controller
- Sets boundary conditions for fuel flows and temperatures within HFRS system piping
- Validated on a level of detail that may be increased for variables of concern in the future, or kept simple for faster simulation speeds
  - Engine is a boundary condition only
  - FCOC heat transfer input is a boundary condition only (expandable)
  - Controllers are used to simulate response lags or system interaction



# Heated Fuel Return System



- Mass and Energy flows are calculated for input to the *Wing submodel*
- Used to tune and optimize system response to wing bay heat loss

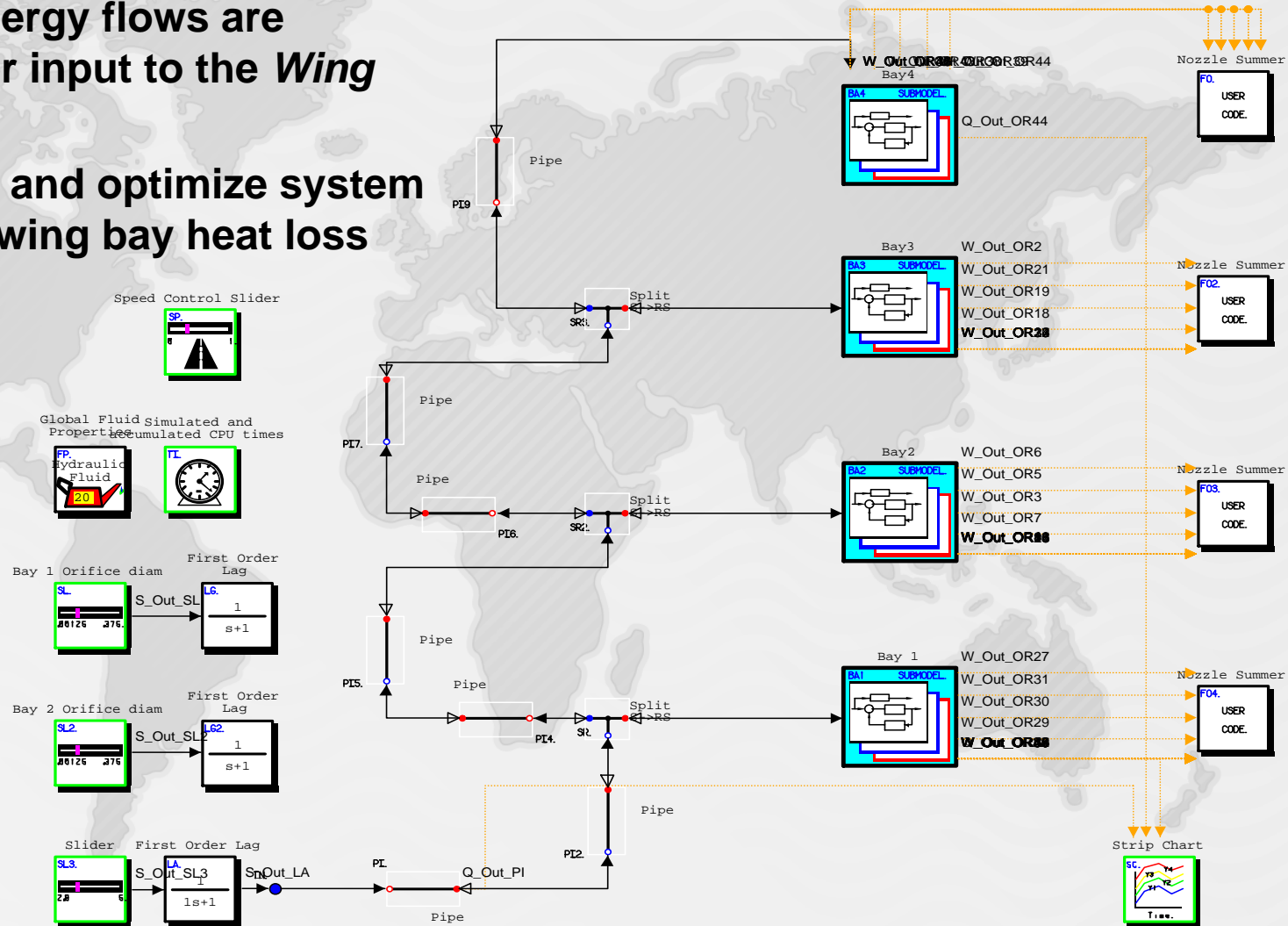



# Wing

- Custom “Fuel Bay” block created as joint effort between Gulfstream and MSC
- Accounts for all mass transfer and heat transfer conditions to simulate fuel temperatures, levels, and migration
- Bays ‘connect’ to form wing

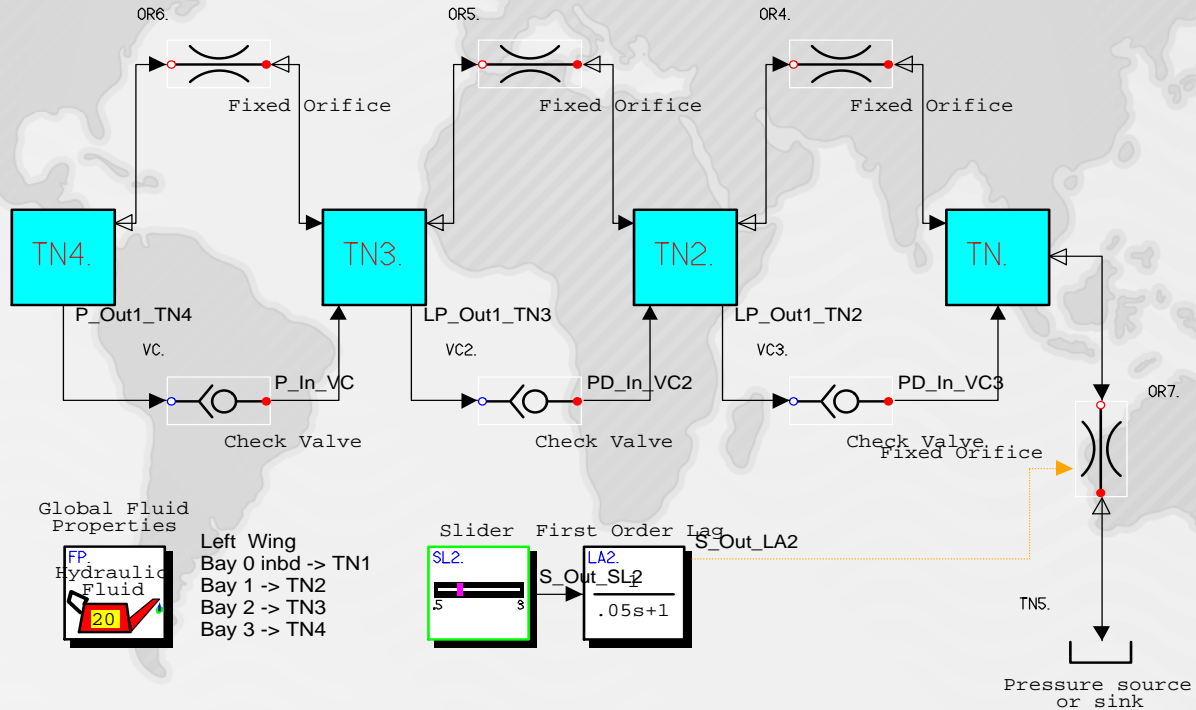

# Validation & Verification

- **Individual submodels validated for proper performance based on existing systems**
  - Used laboratory studies, bench tests, and flight test data
- **Verification of combined Fuel model**
  - Flight test data used as basis
  - Flight profiles input
  - Selected data points compared with flight test results for multiple simulated flights
  - Model control parameters tuned to provide acceptable RMS error
- **Analysis**
  - Model subsystems and components tuned for performance optimization
- **Research validation to be added to *HFRS submodel***
  - Use of CFD software to run batches within MSC Easy5™ simulation loop
  - Laboratory testing used to verify data output from processed CFD batches

# Conclusions

- **System analysis efforts**

- Helped to maintain global leadership in long-range business jet market

- **Model was used to design Heated Fuel Return System**

- Determined minimum heat input
- Determined geometric heat input requirements
- Increased efficiency at worst-case fuel cooling conditions

- **Increased fuel system capabilities**

- Decrease number of refueling stops
- Increase destinations within reach
- Fly higher (colder temperatures) than commuter jet traffic

# Why MSC Easy5™?

- **Lumped parameter modeling method fit criteria for modeling accuracy**
- **Ability to utilize submodel hierarchy for organization and ease of future model iterations for multi-purpose simulation use**
- **Easily communicates with external programs for use in supplemental data processing within the loop for future expansion**
- **Ability to create custom block code components easily and quickly**