

ROI for FEA in Composite Aircraft Part Repair

Use of Finite Element Modeling to Enhance ROI on Aircraft Composite Repair

Fred Perkins
Federal Engineering Associates



Problem: AOG Lost Revenue



- One dead duck can ruin your day
- 1000 seats/day @ \$500 = \$500,000/day
- Cargo = \$250,000/day
- Lost Revenue = \$750,000/day

- Accelerating MRO turnaround is a very powerful driver of enhanced profits.

Spares Inventory is Expensive



Federal Engineering
Associates

- Radomes >\$100,000 dollars
- Articulated aerodynamic control surfaces ~ \$50,000 and up
- Leading Edge ~\$50,000 - \$100,000
- Vertical tail ~ don't even ask
- Spare parts are not always available when needed

What's Wrong?

- **Current composite aircraft part repair practices are highly subjective with variable results.**
- **Repairs cause unintended geometry changes, making reuse difficult or impossible, delaying return to service.**
- **Damage isn't always where expected.**

Leading Edge Example

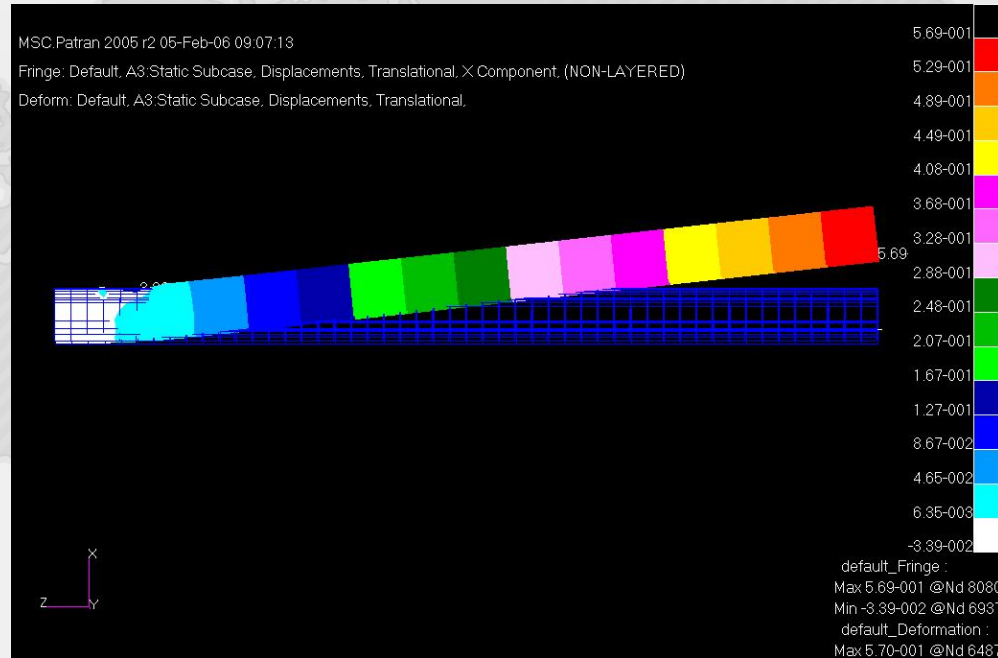
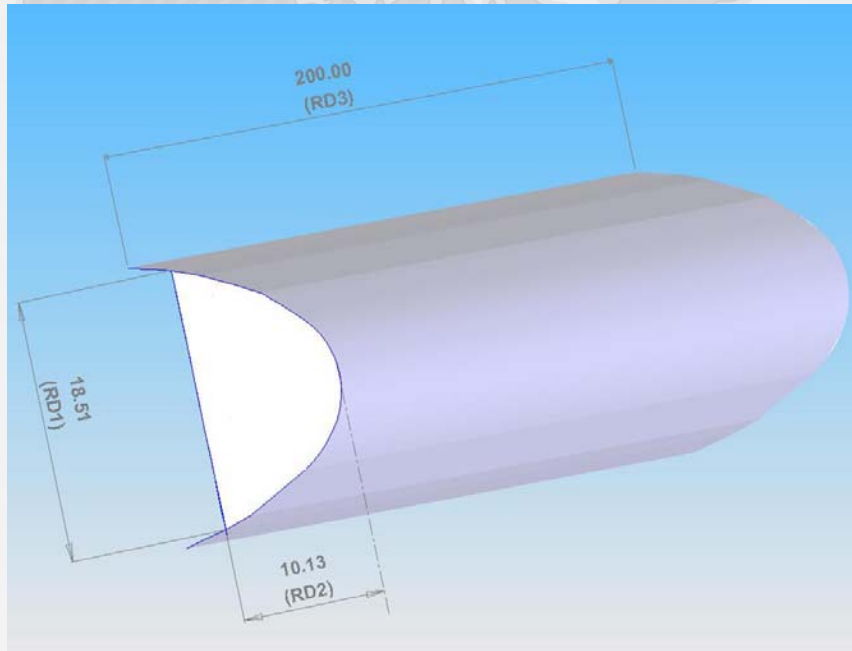

Why Not Analyze?

- Analysis that tells me I have a problem isn't giving me any new information.
- Analyst's priorities not always the same as mechanics'.
- It takes so long to model the parts that it is impractical and too expensive.
- And takes even longer to find a solution to part warping.

A New FEA Approach

- **Develop inventory of frequently repaired part finite element models.**
- **Provide interface that allow mechanics to input damage quickly and directly.**
- **Automatically analyze repair warping and compensating modifications**
- **Determine cost and schedule for likely repairs, allowing rational logistics mgmt.**

Compensating Modifications

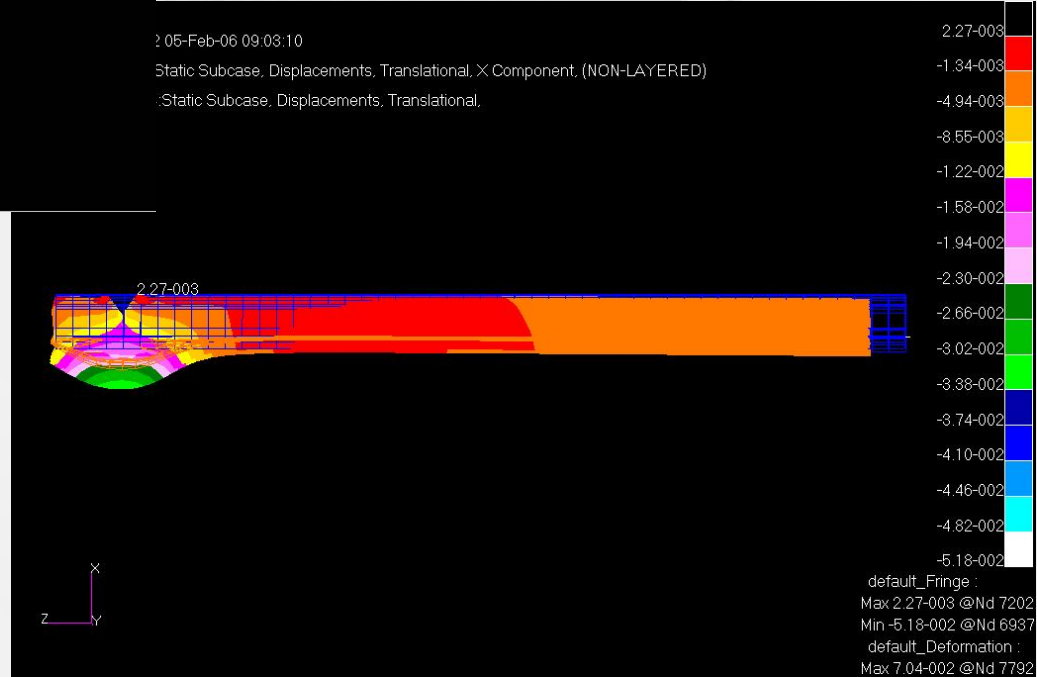
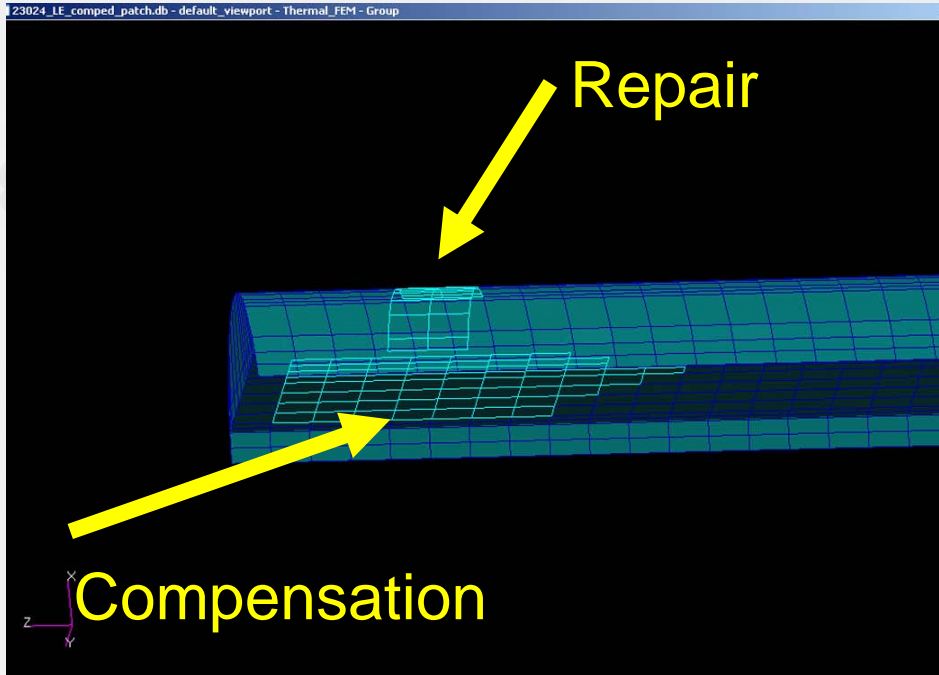

Benefits

- Improved scheduling of aircraft repairs
- More accurate appraisal of spares inventory; needed parts assured
- Improved part repair management, including perishable prepreg and resins
- More consistent, superior repairs
- Faster airplane MRO turnaround

Cost to Implement

- Software and training ~ \$250,000
- Cost per compatible FEM ~\$25-50,000
- FEM per airplane ~ 6-10
- Total investment ~\$500,000 - \$1MM
- For the sake of analysis, assume \$2MM

ROI Basis

- **Assume**
 - 12 airplanes per year
 - One day per airplane saved
 - Baseline 30 critical parts in system, average cost = \$100,000 for new replacement part, one each
 - 25% reduction in spares inventory due to improved analysis
- **Required process investment = \$2MM**

ROI Calculation

- ***Recovered Revenue = \$9MM***
- **20% contribution margin = \$1.8MM**
- **Spare parts savings = \$750,000**
- **Required process investment = \$2MM**

- **5 yr ROI = $5 * (1.8 + .75) / 2 = 638\%$**

Conclusion

- Automated FEM and FEA-driven processes can provide analysis where it's needed most – at the point of repair.
- Impressive FEA ROI is provided by faster turnaround, reduced repair risk, and improved part repair/reuse, thereby reducing needed spares inventory.