

# Finite Element Analysis: Advanced Graphics Software

Presented By  
Structural Dynamics Research Corporation

Copyright, 1980, Structural Dynamics Research Corporation



Structural Dynamics Research Corporation  
2000 Eastman Drive  
Milford, Ohio 45150  
513/576-2400

# SDRC GRAPHICS SYSTEM

## PURPOSE

- 1) Educate in CAE Approach
- 2) Broaden User Knowledge
- 3) Organize User Feedback
- 4) Introduce Significant Enhancements

## SDRC GRAPHICS HISTORY

### SUPERTAB Version 1

- Create Model
- Display
- Edit
- Utility

Core based System

## **SDRC GRAPHICS HISTORY**

### **SUPERTAB Version 2**

- Surface Mesh Generator
- Local Coordinate Systems
- Enhanced Tablet Flexibility
- Enhanced Viewing Capabilities

Disk based System

## **SDRC GRAPHICS HISTORY**

### **SUPERTAB Version 3**

- Menu Mode

## **SDRC GRAPHICS HISTORY**

### **SUPERTAB Version 4**

- Node and Element Reflect
- Midnode Generation
- Free-edge Checking
- Coincident Node Checking

## **SDRC GRAPHICS HISTORY**

### **OUTPUT DISPLAY Version 1**

- Compatible Viewing Capabilities
- Entity Grouping
- Utility
- Shell Stress Contours
- Color Graphics

## **SDRC GRAPHICS**

### **SUPERTAB Version 5**

- Geometric Modeling
- Enhanced Surface Mesh Generator
- Nodal Forces
- Restraints
- Enhanced Entity Grouping
- Coordinate System Display
- Color Graphics
- Reorganized Command Structure

## **SDRC GRAPHICS**

### **SUPERTAB Version 5**

- Geometric Modeling
- Enhanced Surface Mesh Generator
- Nodal Forces
- Restraints
- Enhanced Entity Grouping
- Coordinate System Display
- Color Graphics
- Reorganized Command Structure

# g**SUPERTAB**

## Announcing SUPERTAB 6

GEOMETRIC MODELING AND MESH  
GENERATION TAKE PRECEDENCE

In 1975 SDRC introduced the concept of interactive finite element model preparation. The major capability was the ability to digitize three-dimensional points in space. In the last six years, finite element modeling technology has made rapid advancements. Designers and analysts want to geometrically define objects in space and generate nodes and elements within the defined boundaries. SDRC SUPERTAB makes these concepts — geometric modeling and mesh generation — a reality. Let's take a close look at the specific enhancements of SUPERTAB 6.

### ENHANCEMENTS TO MESH GENERATION

- Generate three-dimensional solid meshes using linear, parabolic, or cubic solid and thick shell elements.
- The ability to assign a bias type to each entity on a compound edge (an edge consisting of multiple entities) and to assign a different number of elements to be created on each edge.

### ENHANCEMENTS TO POINT CREATION

- Generate points between points.
- Copy points.
- Reflect points.

### ENHANCEMENTS TO SURFACE CREATION

- Create surfaces from points. Previously users had to detect the appropriate number of points to create a line, arc, or spline, then select or combine the lines, arcs, and splines to create edges. Three or four edges define a surface and five or six surfaces define a volume. Now when creating surfaces the user can simply select two points to create a line and an edge. Similarly, selecting three points will create an arc and an edge and selecting four or more points will create a spline and an edge.

### ENHANCEMENTS TO LOADS

- Apply pressures on user-defined element faces.

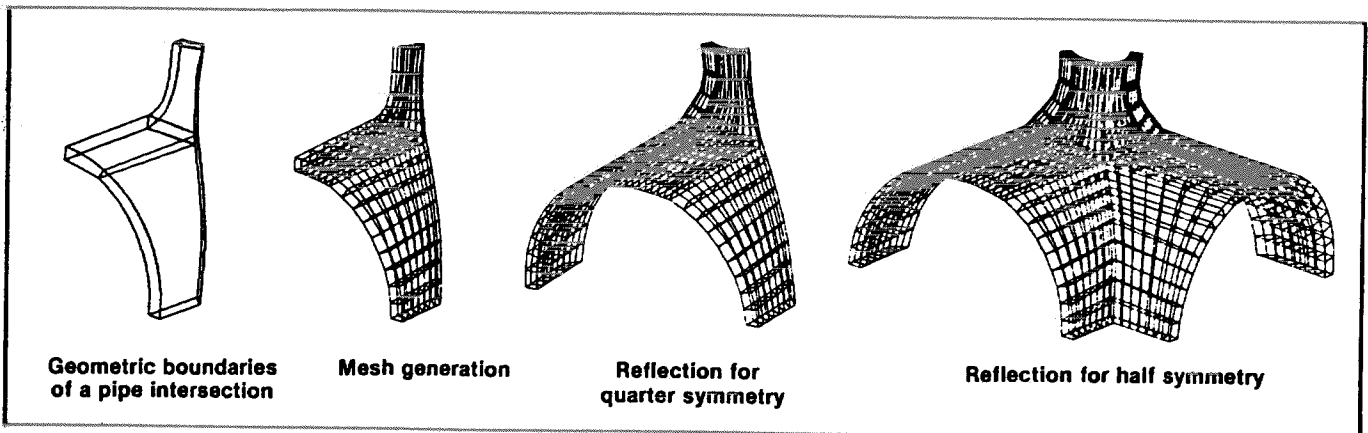

### ENHANCEMENTS TO MODEL CHECKING

- Perform an element distortion check on all isoparametric elements, resulting in a list of all elements that do not meet the user-defined criteria.
- Perform a warped element check on a user-specified range of 4-noded shells to determine if the fourth node is at an unacceptable distance out of the plane of the first three nodes.

### ADDITION OF TABLES CAPABILITY

- Input information into Element Type Tables, Element Property Tables, and Material Property Tables.
- Output these tables for SDRC SUPERB, NASTRAN<sup>(1)</sup>, ANSYS<sup>(2)</sup>, SDRC SASA, and SDRC SAGS.
- Create user-defined general tables.

### ADDITION OF RENUMBERING CAPABILITY

- Sequential Renumbering
- Nodal Bandwidth Optimization
- Element Wavefront Optimization

<sup>(1)</sup>NASTRAN — MacNeal-Schwendler Corporation

<sup>(2)</sup>ANSYS — Swanson Analysis Systems

# **SDRC GRAPHICS**

## **SUPERTAB Version 5**

- **Geometric Modeling**
- **Enhanced Surface Mesh Generator**
- **Nodal Forces**
- **Restraints**
- **Enhanced Entity Grouping**
- **Coordinate System Display**
- **Color Graphics**
- **Reorganized Command Structure**

DEFINITION

GEOMETRIC MODELING

A technique for representing three dimensional objects using basic geometric entities.

FINITE ELEMENT MODEL

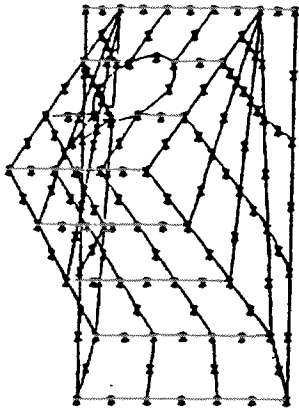

GEOMETRIC MODEL

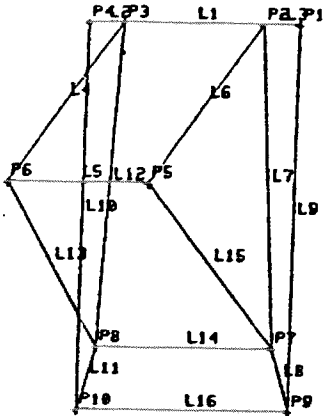

## DEFINITION

### *MESH*

An entity associated with a surface which defines the pattern of nodes and elements that will be generated on that surface.

### MESH

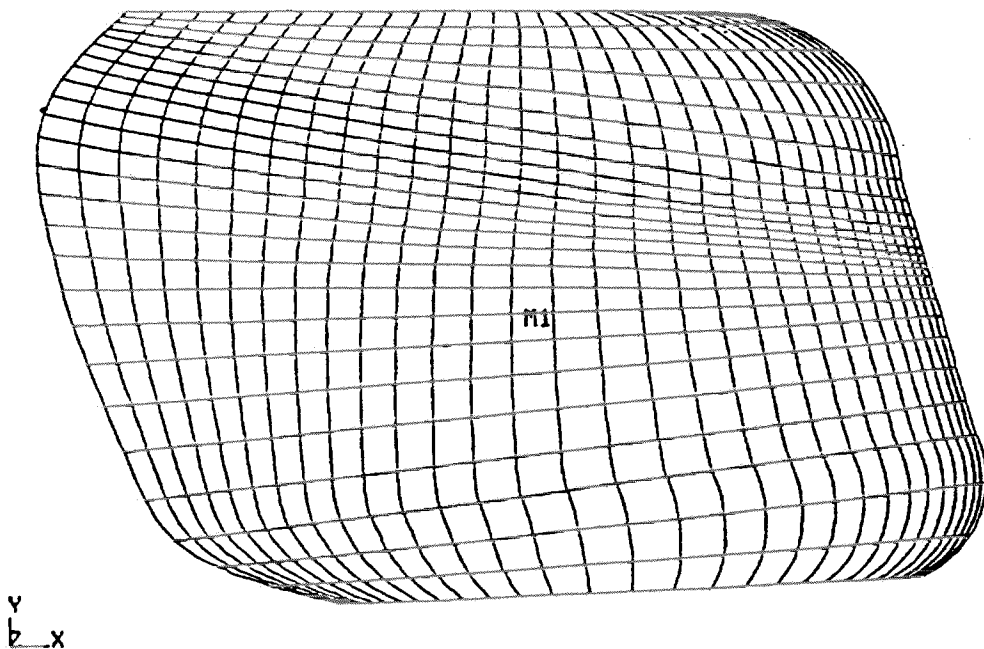



# SDRC GRAPHICS

## SUPERTAB Version 5

- Geometric Modeling
- Enhanced Surface Mesh Generator
- Nodal Forces
- Restraints
- Enhanced Entity Grouping
- Coordinate System Display
- Color Graphics
- Reorganized Command Structure

### DEFINITION

#### *NODAL FORCE*

A force applied at a node.

### DEFINITION

#### *RESTRAINT*

A displacement constraint applied at a node.

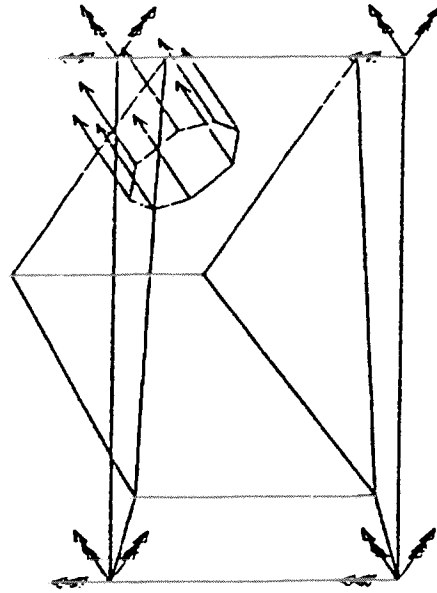

## **SDRC GRAPHICS**

### **SUPERTAB Version 5**

- Geometric Modeling
- Enhanced Surface Mesh Generator
- Nodal Forces
- Restraints
- Enhanced Entity Grouping
- Coordinate System Display
- Color Graphics
- Reorganized Command Structure

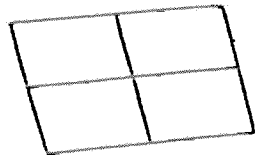
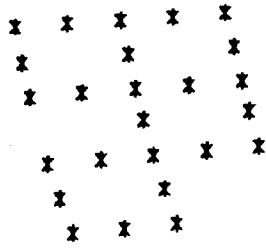
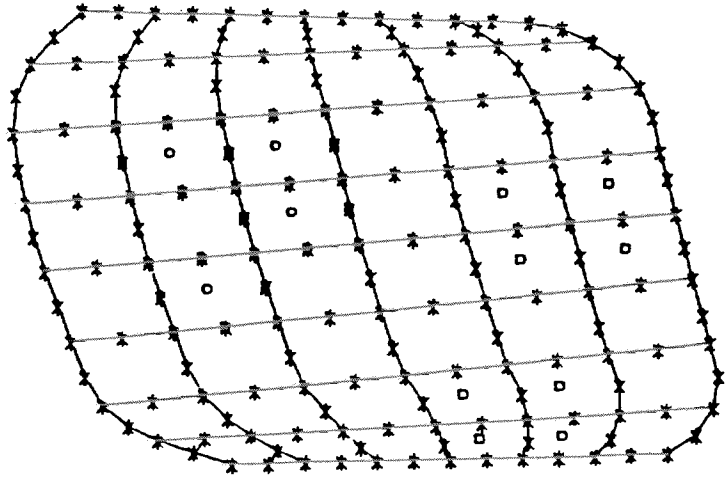

# SDRC GRAPHICS

## SUPERTAB Version 5

- Geometric Modeling
- Enhanced Surface Mesh Generator
- Nodal Forces
- Restraints
- Enhanced Entity Grouping
- Coordinate System Display
- Color Graphics
- Reorganized Command Structure

### COORDINATE SYSTEM DISPLAY

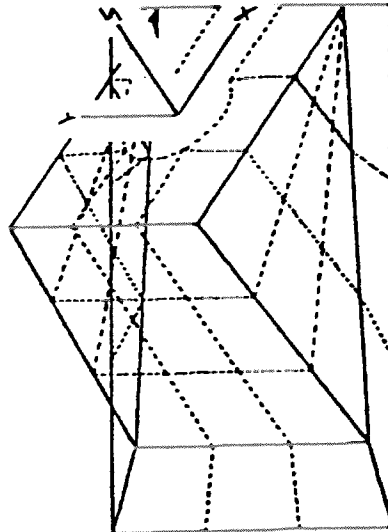

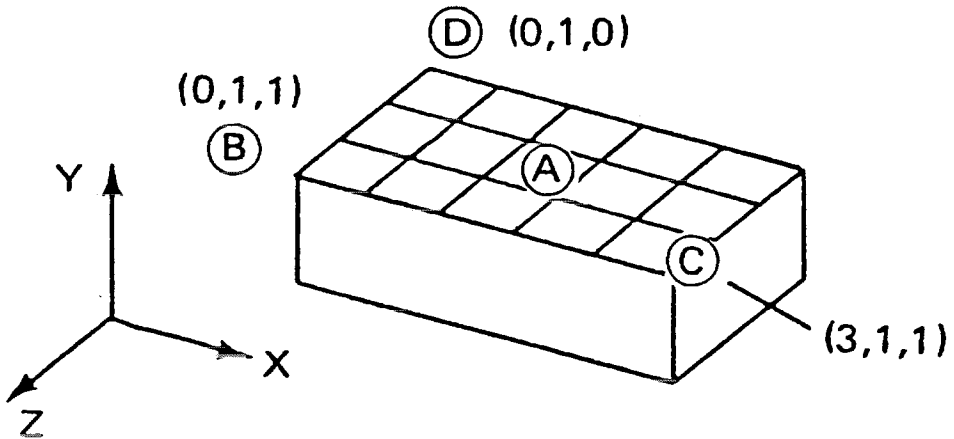
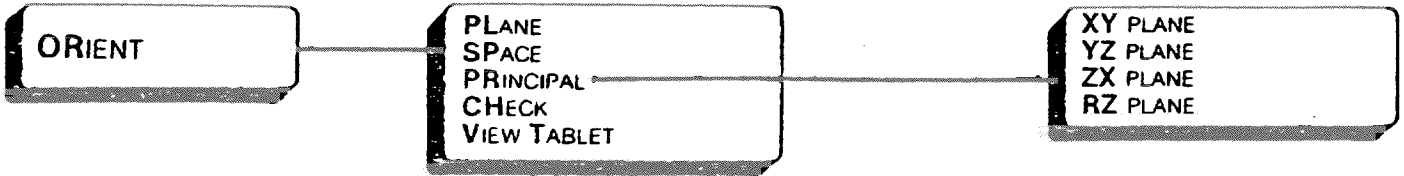
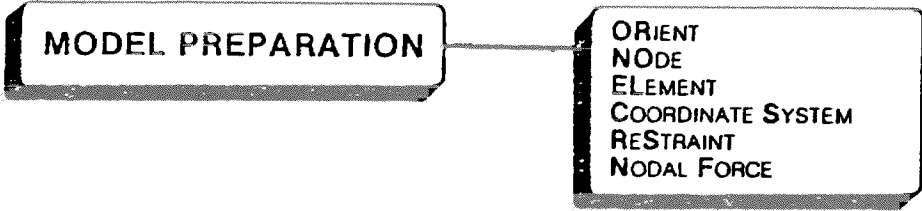

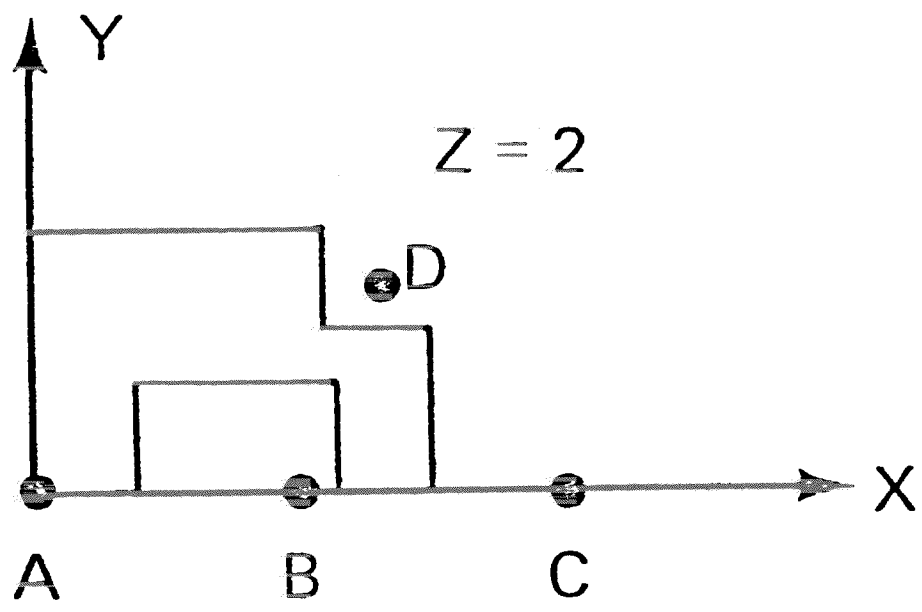
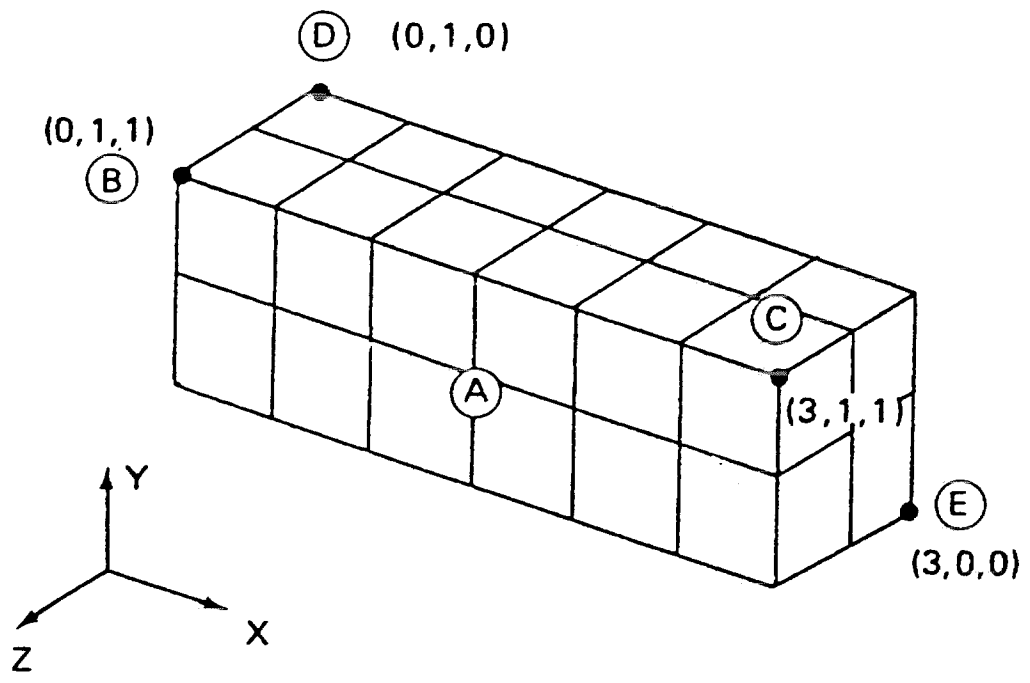

NODE

CREATE  
DIGITIZE  
DIGITIZE VIEW 1  
DIGITIZE VIEW 2  
BETWEEN NODES  
COPY  
REFLECT  
PARAMETER  
SKETCH  
LABEL  
LIST  
PURGE  
MODIFY\*

LABEL  
INCREMENT  
DEFINITION COORDINATE  
SYSTEM  
DISPLACEMENT COORDINATE  
SYSTEM  
COLOR  
GENERATION SYSTEM  
STATUS

LABEL  
DEFINITION COORDINATE  
SYSTEM  
DISPLACEMENT COORDINATE  
SYSTEM  
COLOR  
ON ELEMENTS  
CURRENT GROUP

\* in MODIFY only  
LABEL  
DEFINITION COORDINATE  
SYSTEM  
DISPLACEMENT COORDINATE  
SYSTEM  
COLOR  
LOCAL COORDINATE  
GLOBAL COORDINATE

1  
2  
3  
4  
5  
6  
7  
8  
9  
10  
11  
12  
13  
14  
15  
16  
17  
18  
19  
20  
21  
22  
23  
24  
25  
26  
27  
28  
29  
30  
31  
32  
33  
34  
35  
36  
37  
38  
39  
40  
41  
42  
43  
44  
45  
46  
47  
48  
49  
50  
51  
52  
53  
54  
55  
56  
57  
58  
59  
60  
61  
62  
63  
64  
65  
66  
67  
68  
69  
70  
71  
72  
73  
74  
75  
76  
77  
78  
79  
80  
81  
82  
83  
84  
85  
86  
87  
88  
89  
90  
91  
92  
93  
94  
95  
96  
97  
98  
99  
100

NODE PARAMETER DEFINITION\_  
COORDINATE SYSTEM 0 (CARTESIAN)

NODE BETWEEN\_NODES

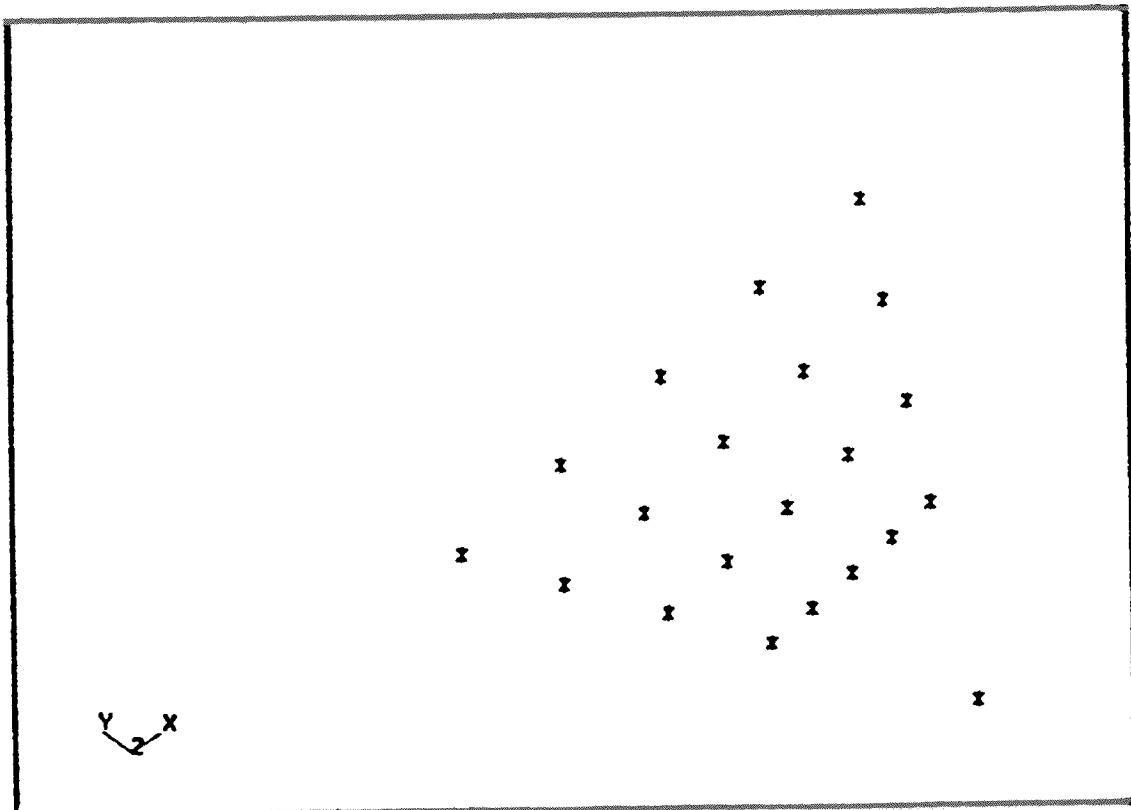
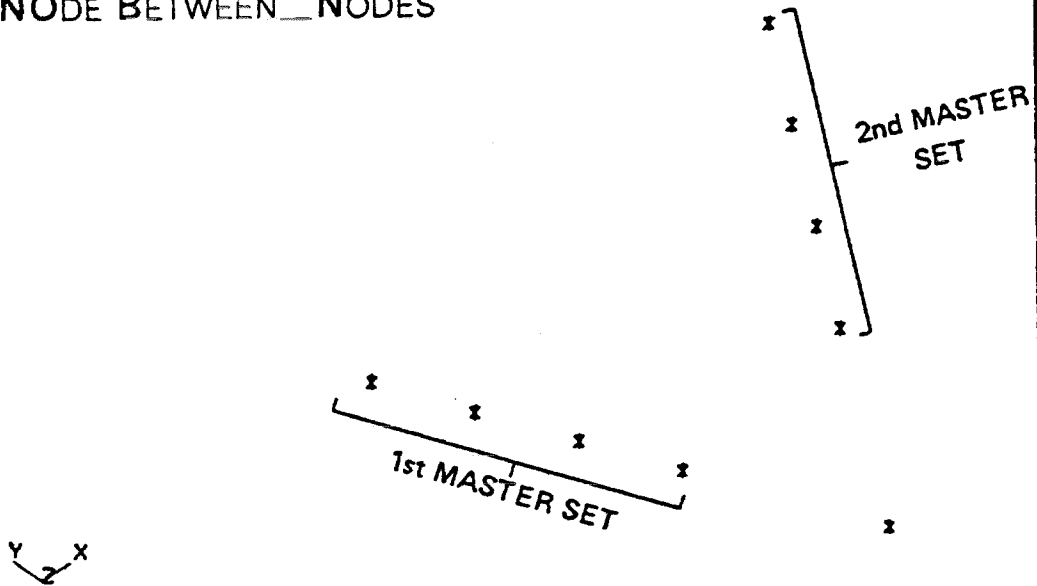



NODE PARAMETER DEFINITION\_\_  
COORDINATE SYSTEM 1 (CYLINDRICAL)  
NODE BETWEEN\_\_NODES

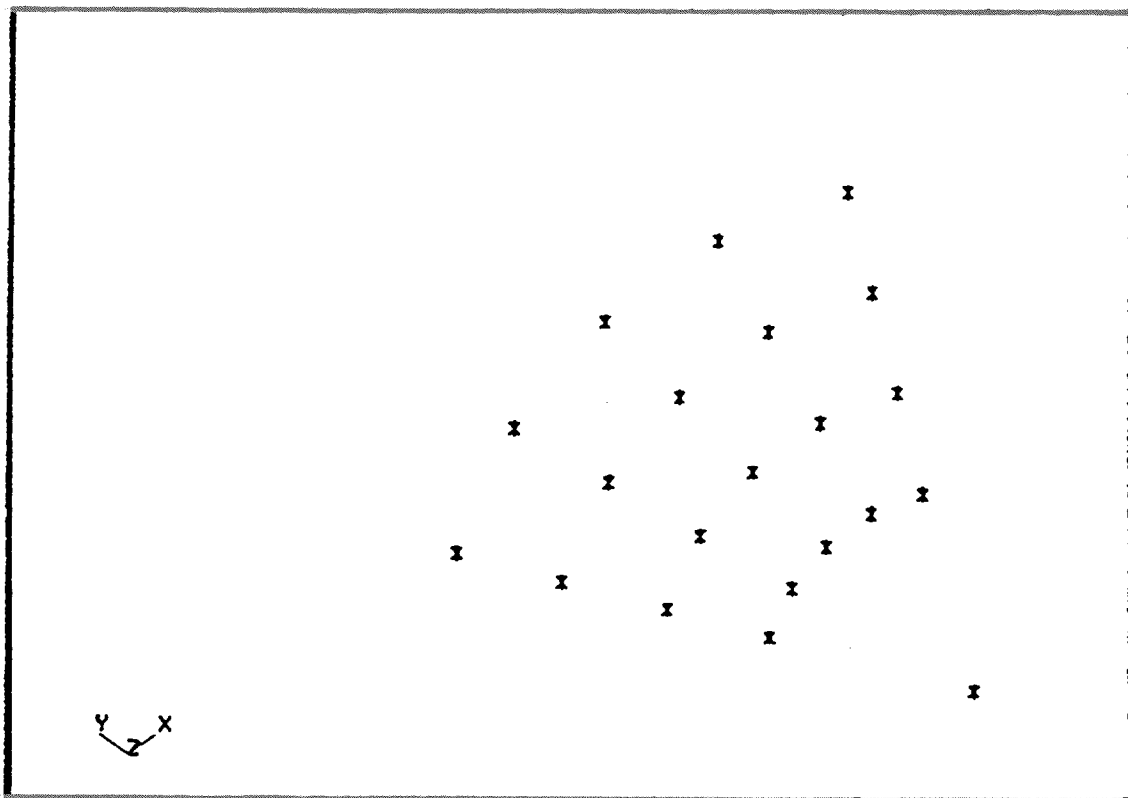
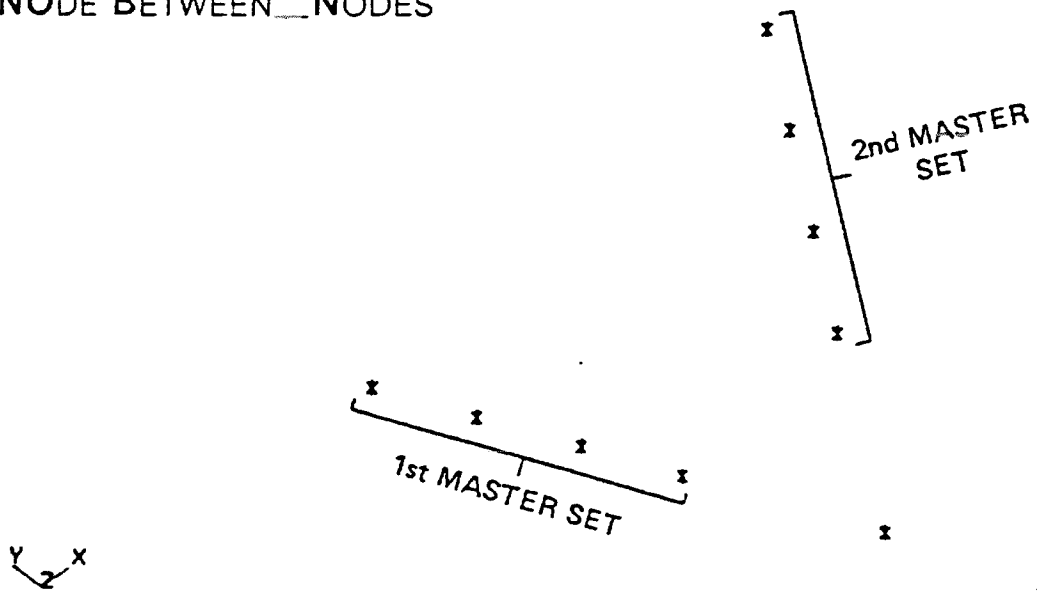

# NODE REFLECT

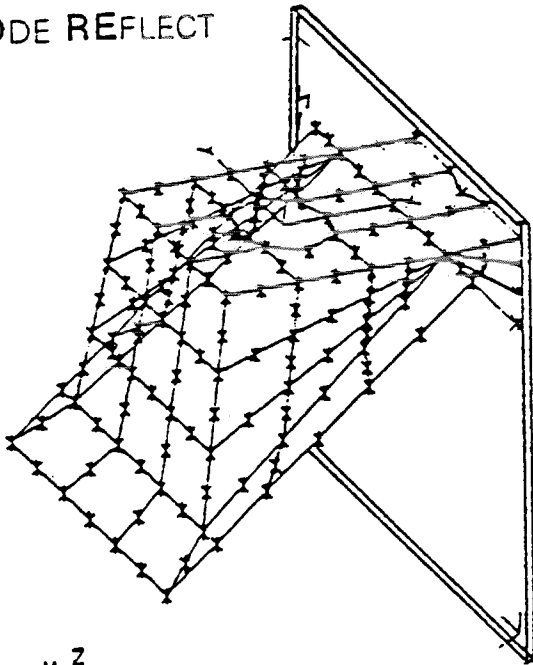

x  
y z

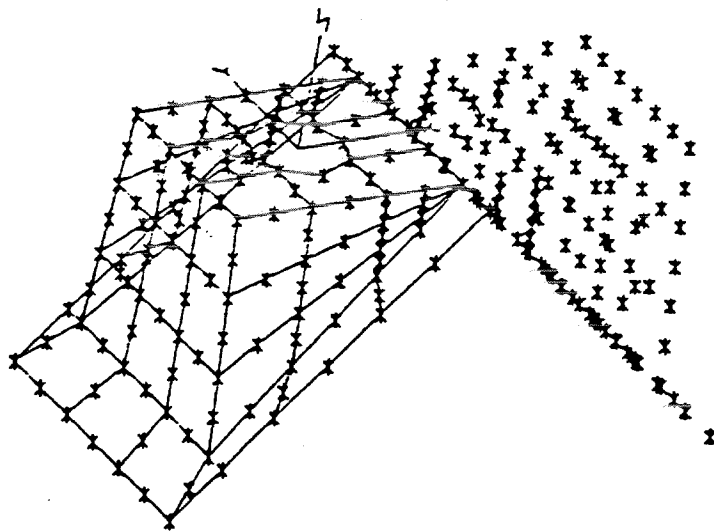

x  
y z

LINEAR BEAM



PARBOLIC BEAM



CUBIC BEAM



LINEAR SHELL

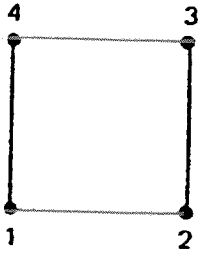

LINEAR THICK SHELL

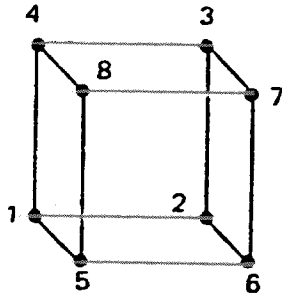

LINEAR SOLID

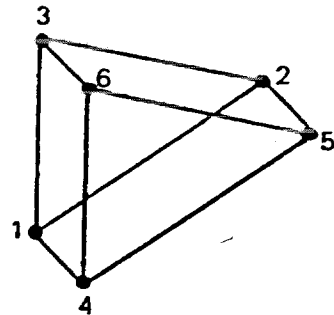
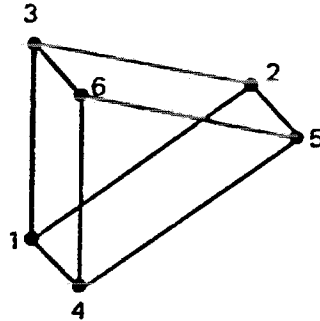
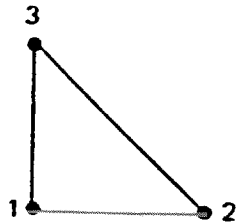
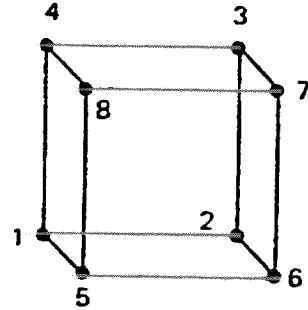

### PARABOLIC SHELL

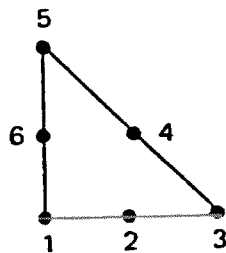
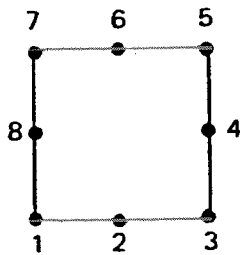

### PARABOLIC THICK SHELL

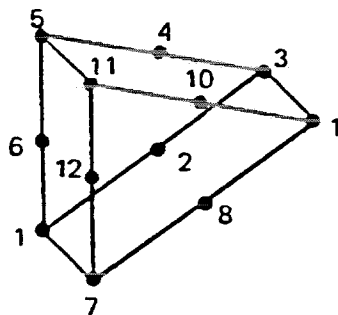
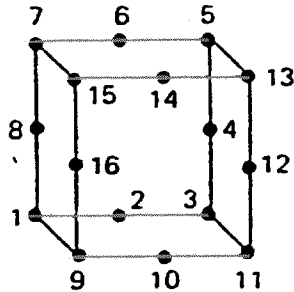

### PARABOLIC SOLID

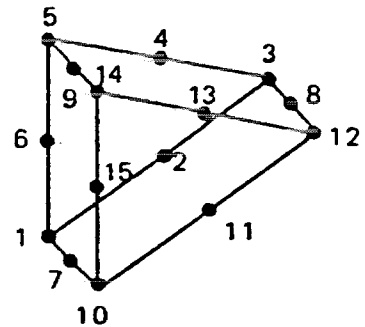
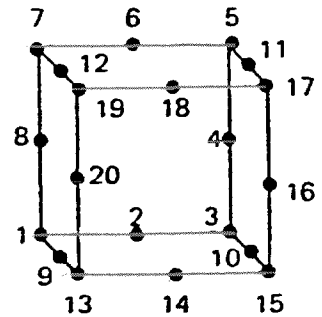

### CUBIC SHELL

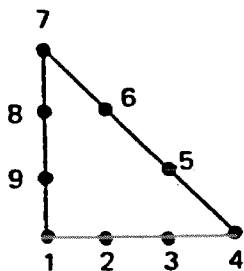
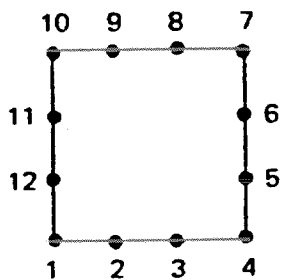

### CUBIC THICK SHELL

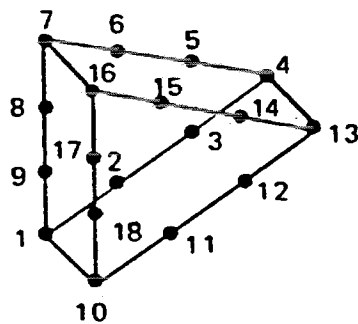
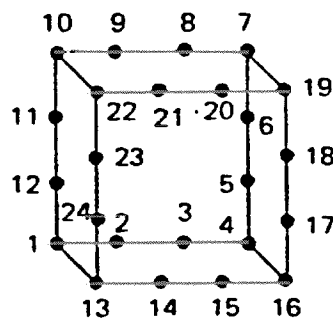

### CUBIC SOLID

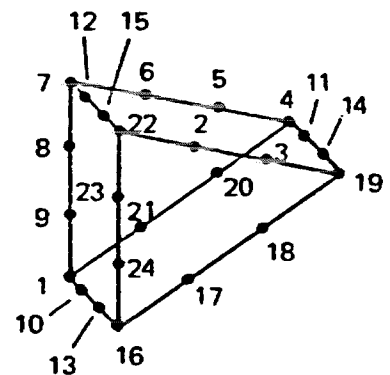
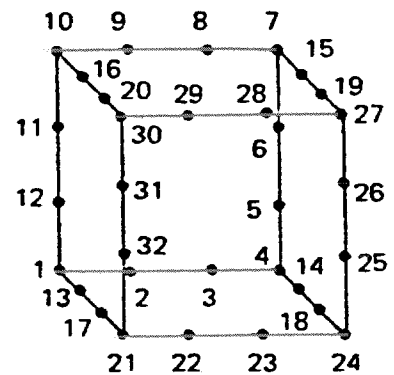

# ELEMENT CREATE

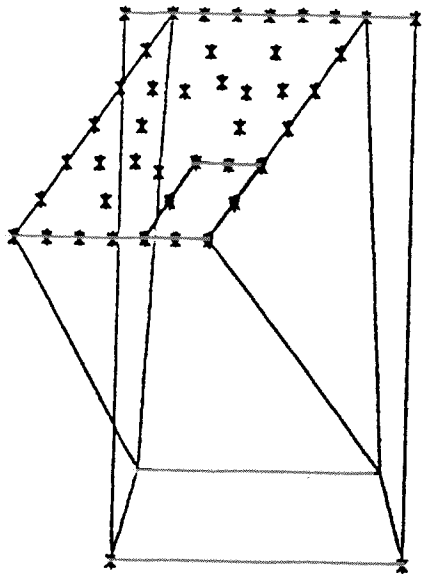
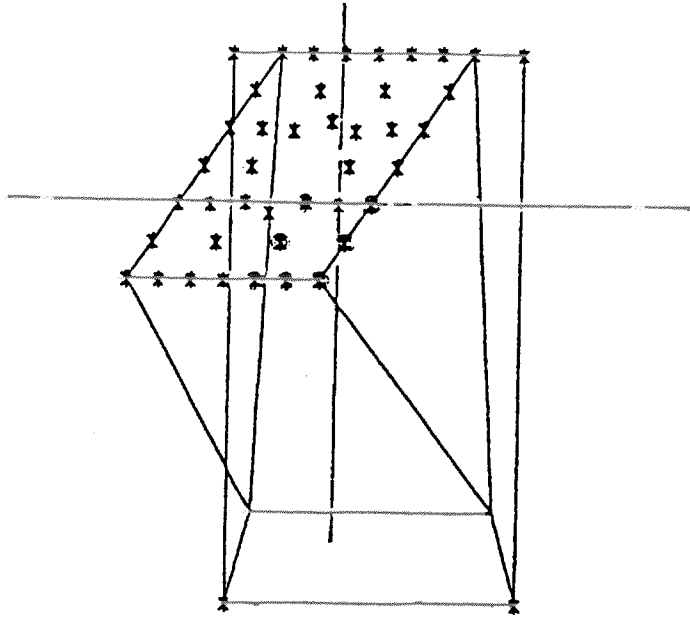

**NODE PARAMETER GENERATION**

SYSTEM 0 (CARTESIAN)

**ELEMENT MIDNODE**

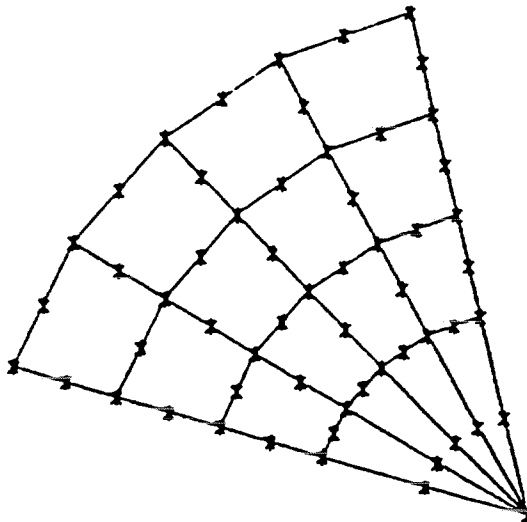
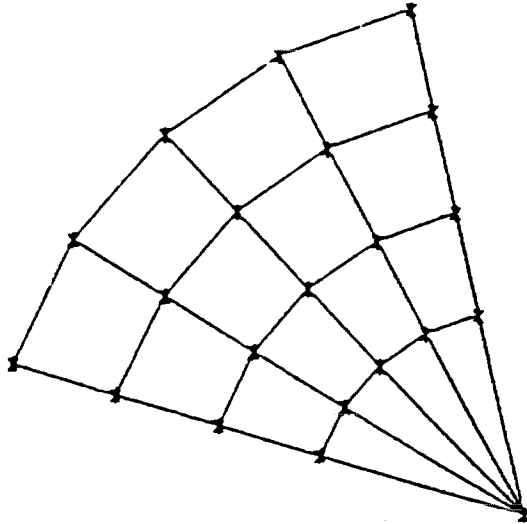

NODE PARAMETER GENERATION  
SYSTEM 1 (CYLINDRICAL)  
ELEMENT MIDNODE

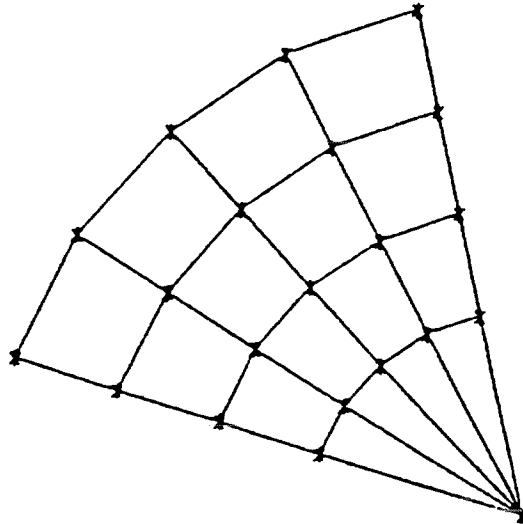

Y  
X

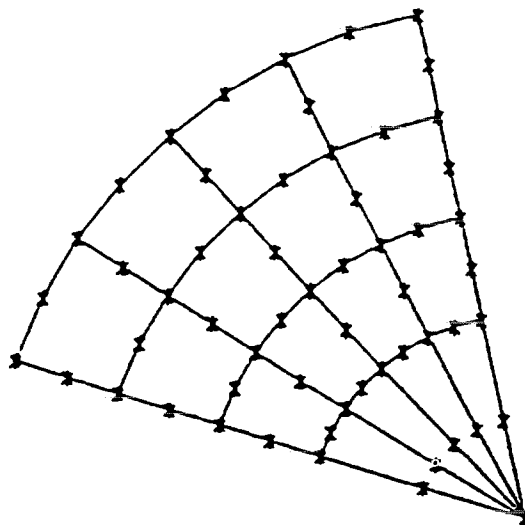

Y  
X

ELEMENT REFLECT

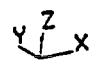
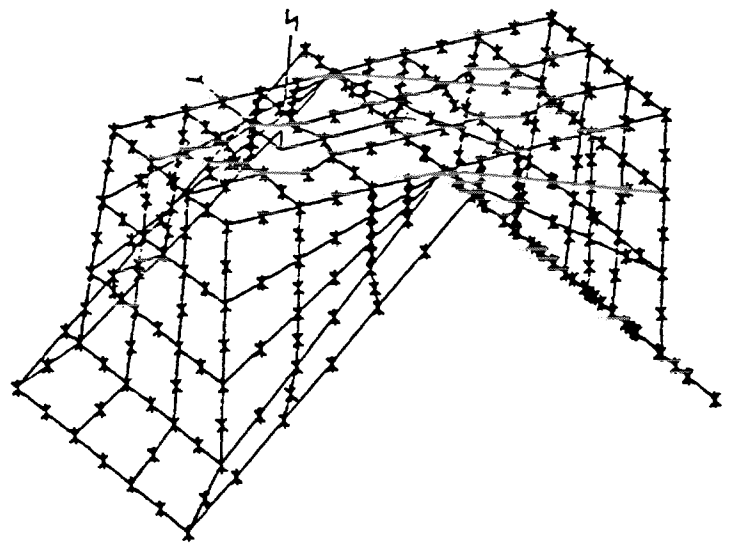
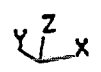
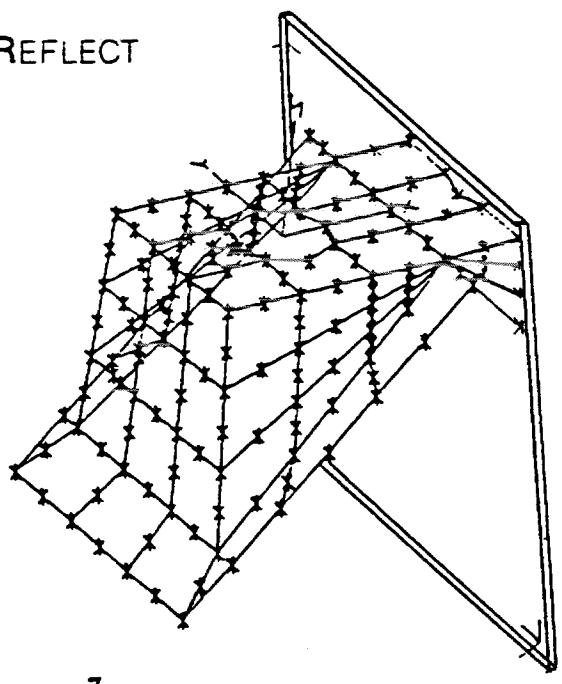



COORDINATE  
SYSTEM

CREATE  
LIST  
MODIFY  
SKETCH

LABEL  
TYPE  
REFERENCE SYSTEM  
COLOR  
CURRENT GROUP

TYPE  
COLOR  
REFERENCE SYSTEM  
REFERENCE ORIGIN  
REFERENCE + X AXIS  
REFERENCE + XZ AXIS  
GLOBAL ORIGIN  
GLOBAL + X AXIS  
GLOBAL + XZ AXIS

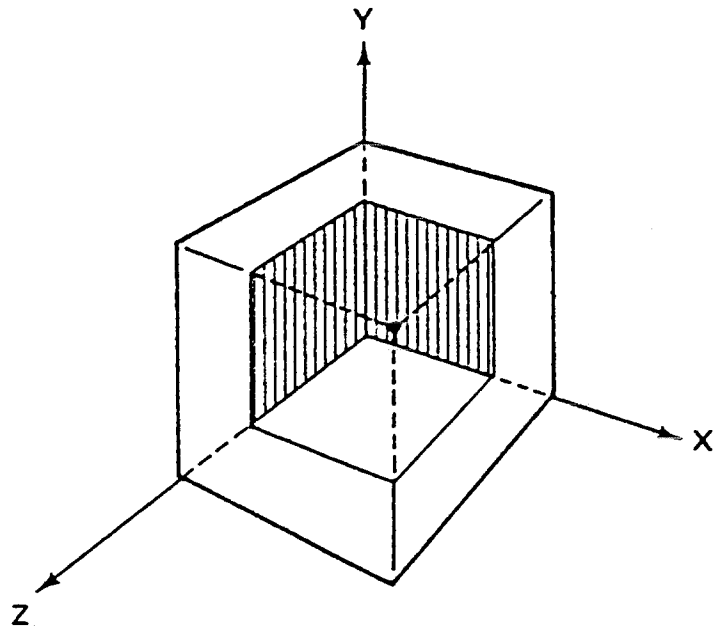

Cartesian Coordinate System 0  
 $X, Y, Z$

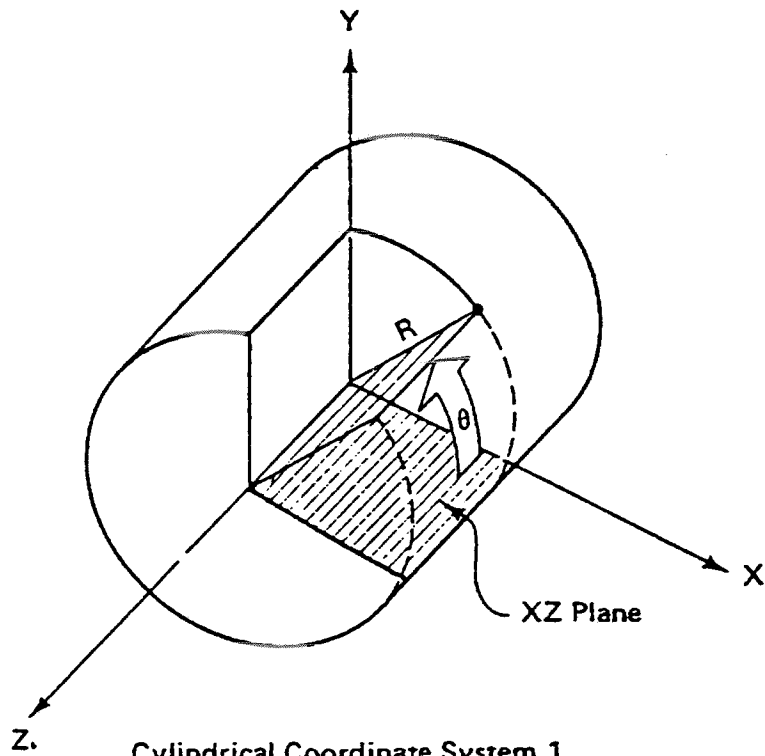

Cylindrical Coordinate System 1  
 $R, \theta, Z$

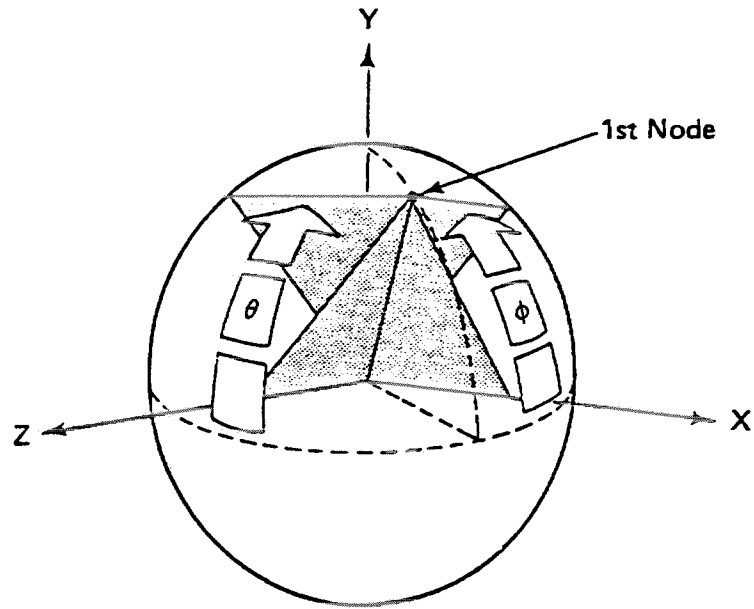

Spherical Coordinate System 2  
 $R, \theta, \phi$

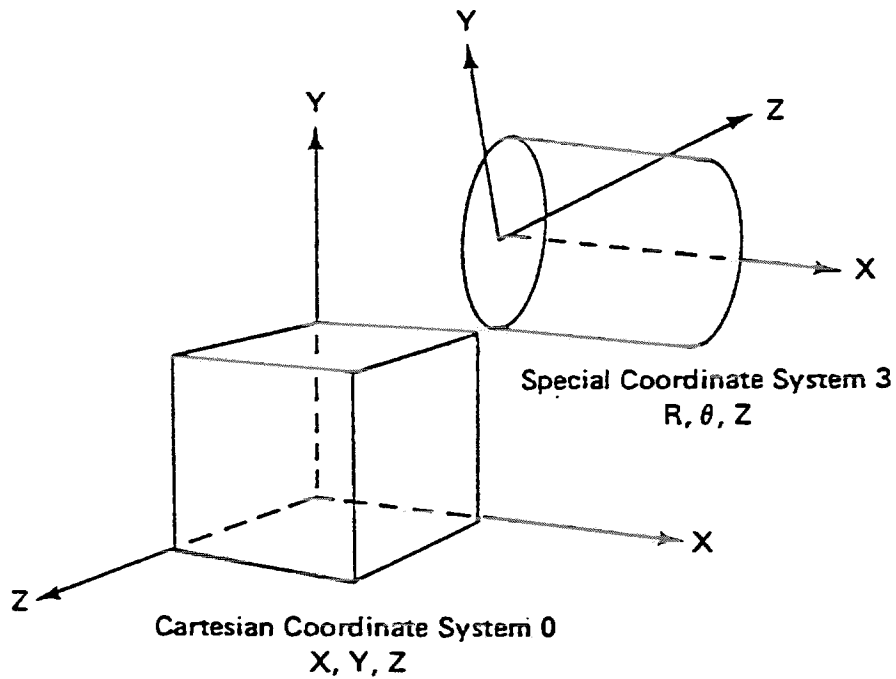

Cartesian Coordinate System 0  
 $X, Y, Z$

Special Coordinate System 3  
 $R, \theta, Z$

# COORDINATE\_SYSTEM MODIFY

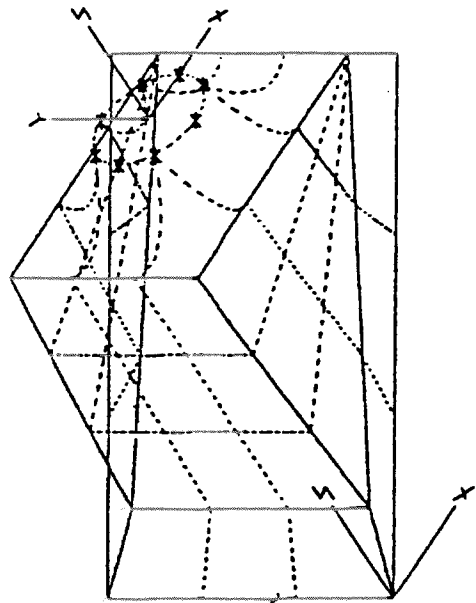
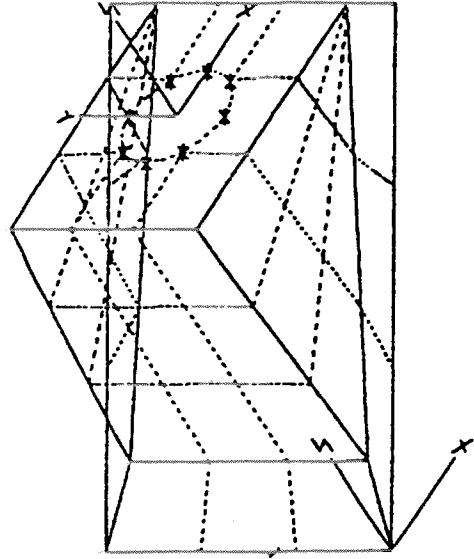

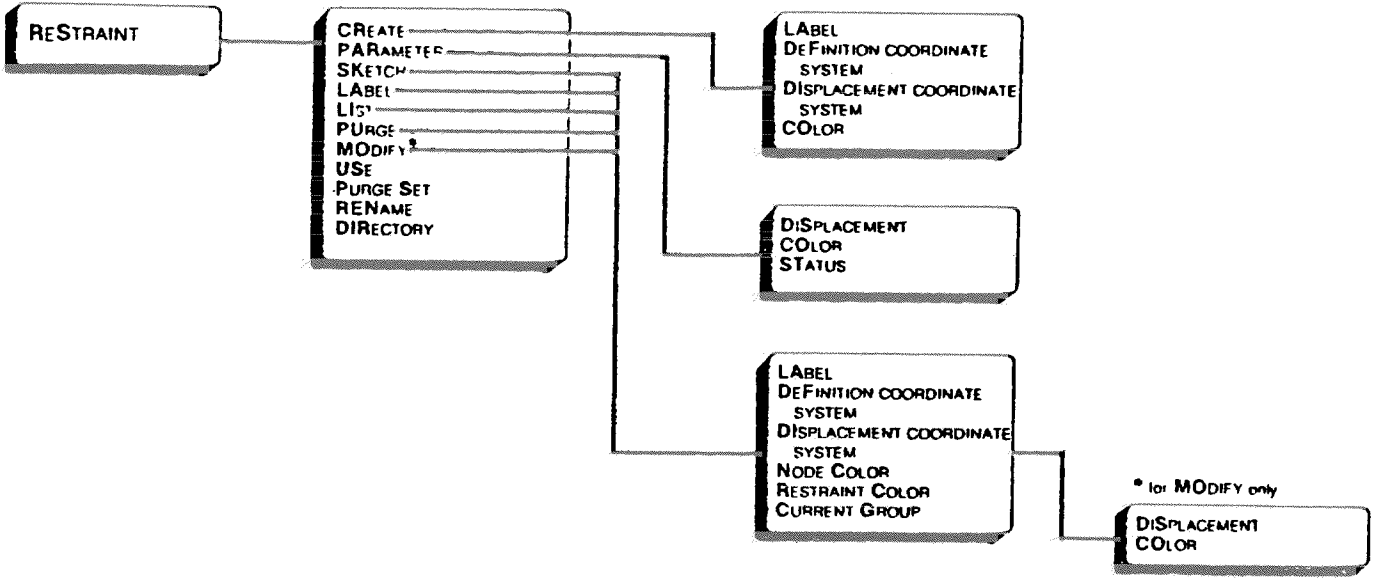

## RESTRAINT

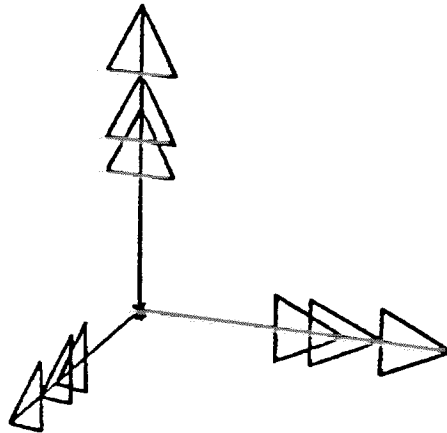

RESTRAINT LABEL LABEL 174

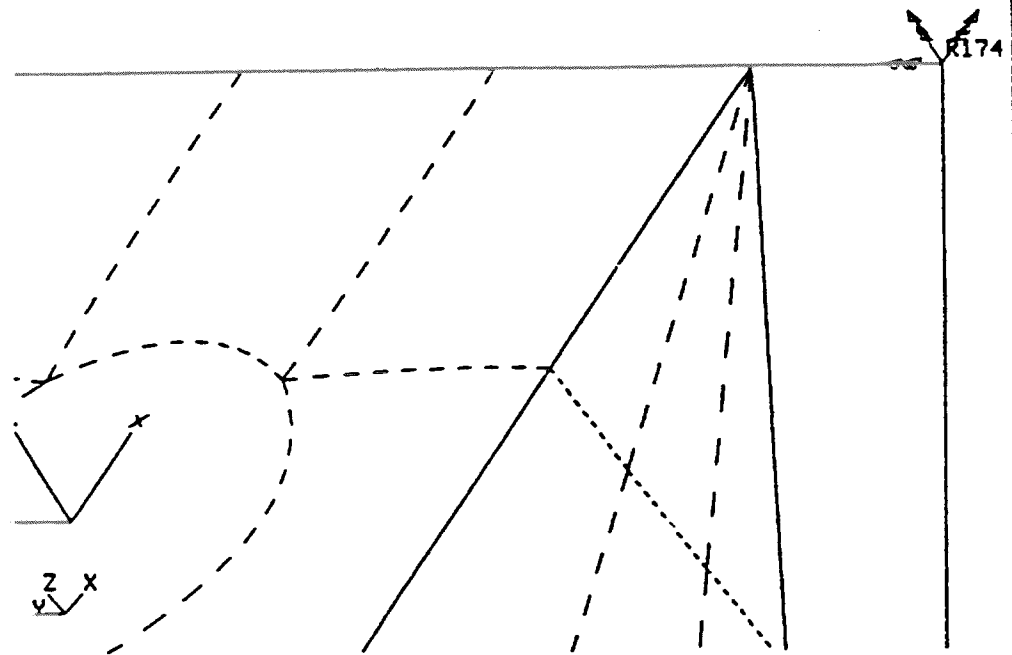
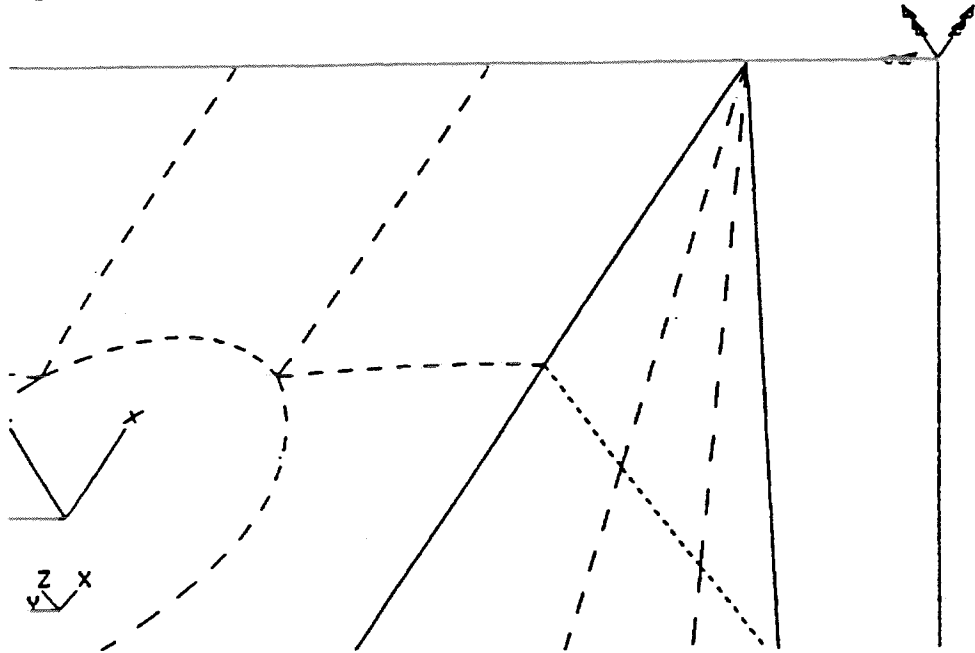

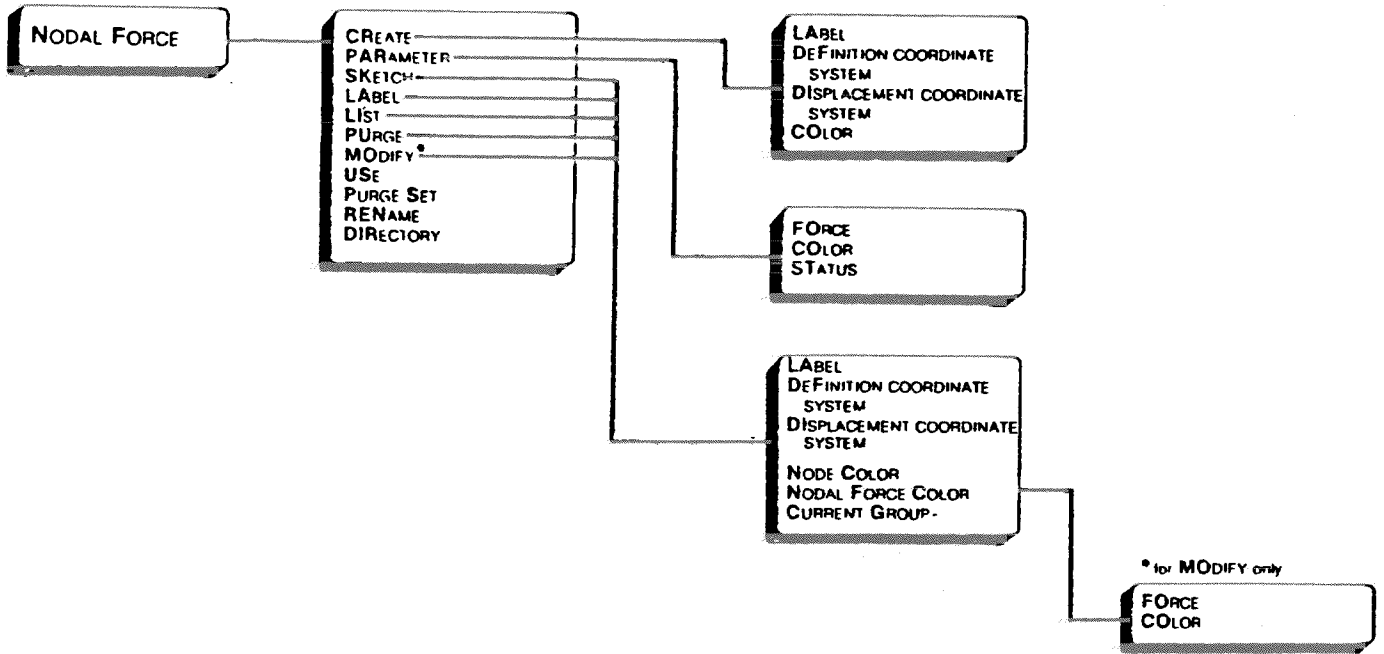

## NODAL FORCE

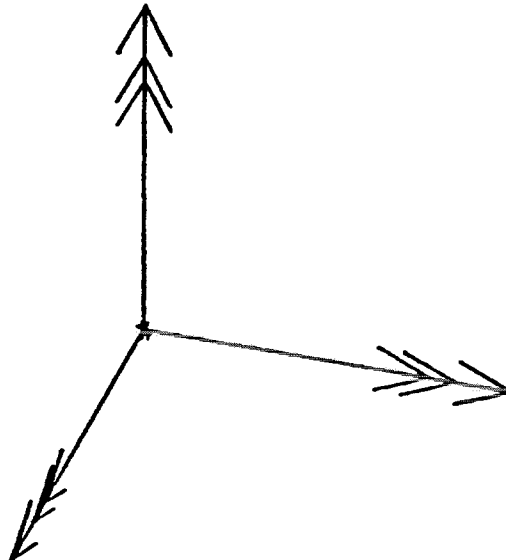

NODAL\_FORCE SKETCH LABEL 1,999

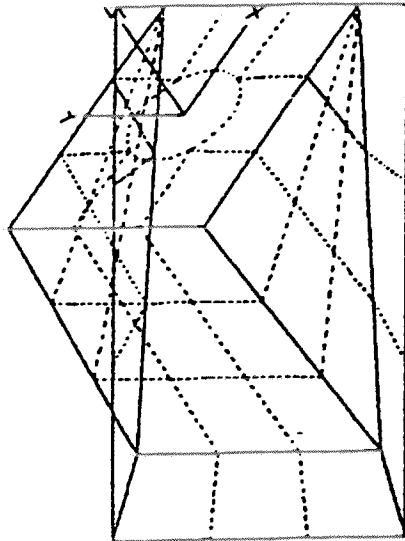



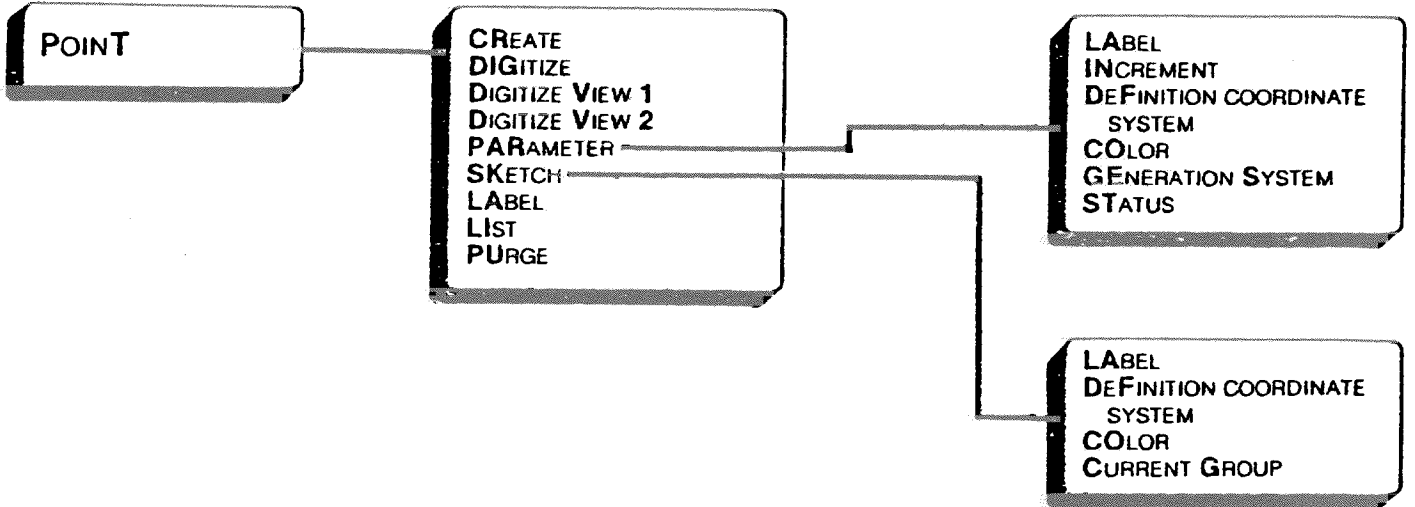
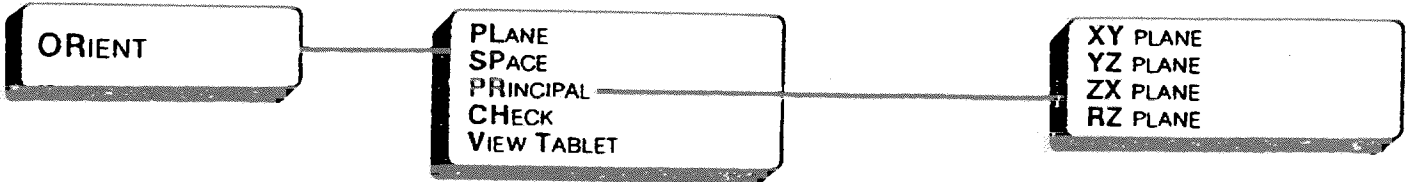
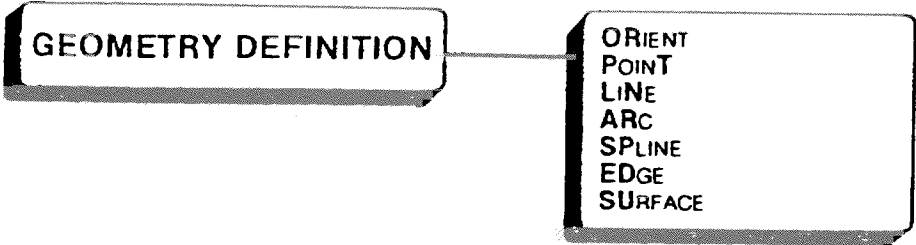

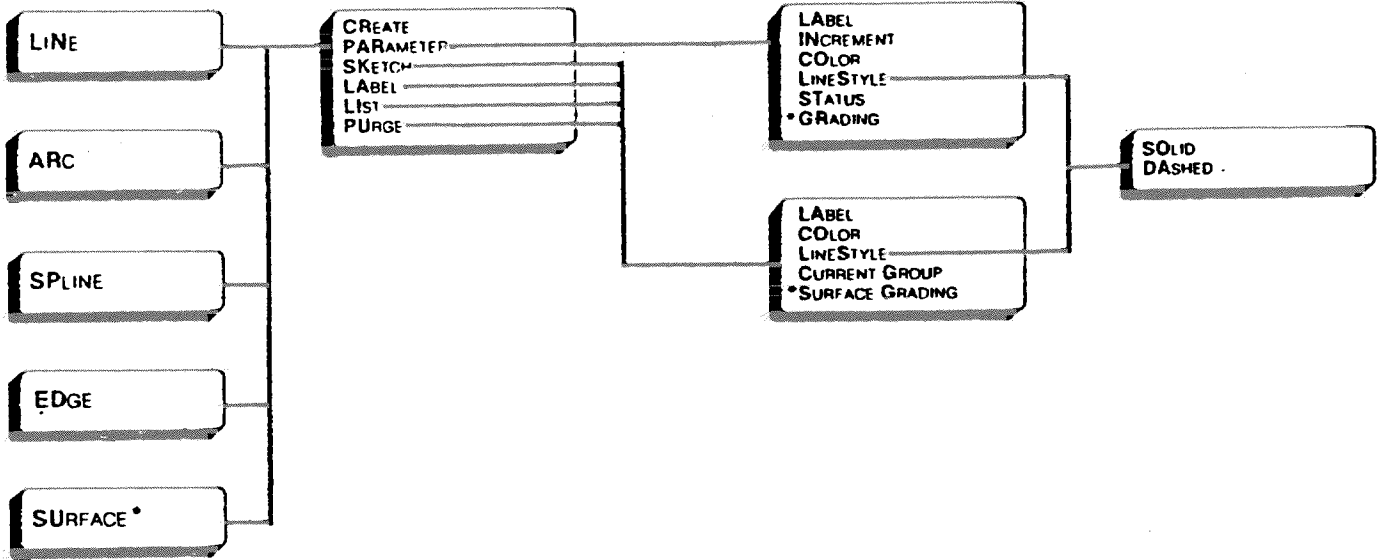

# LINE CREATE

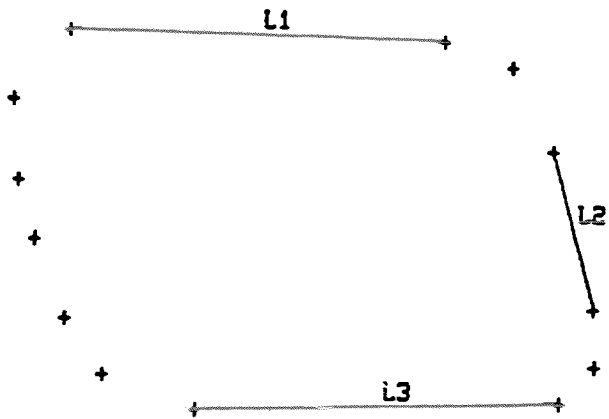

# EDGE CREATE

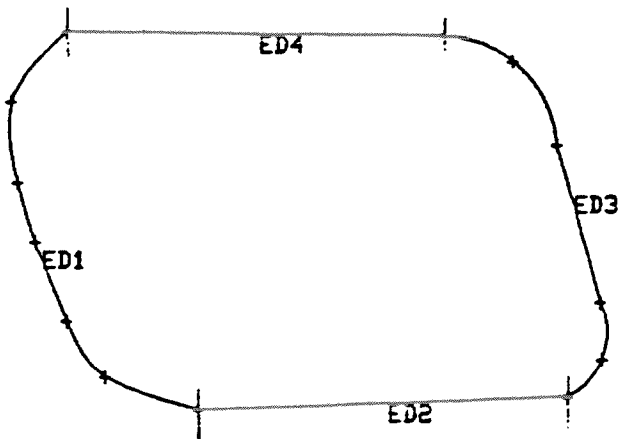
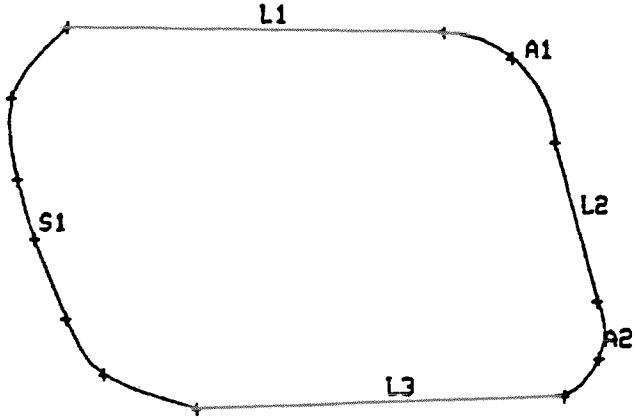

# SURFACE CREATE

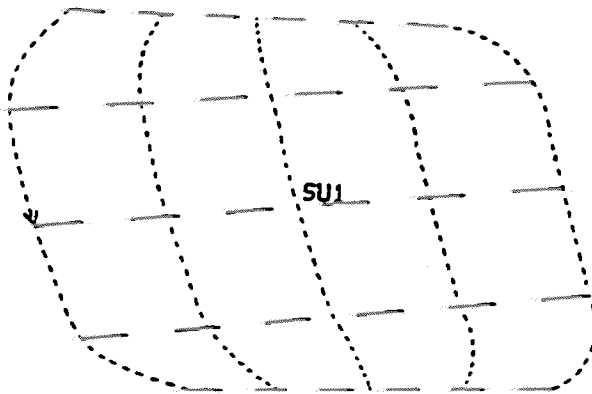
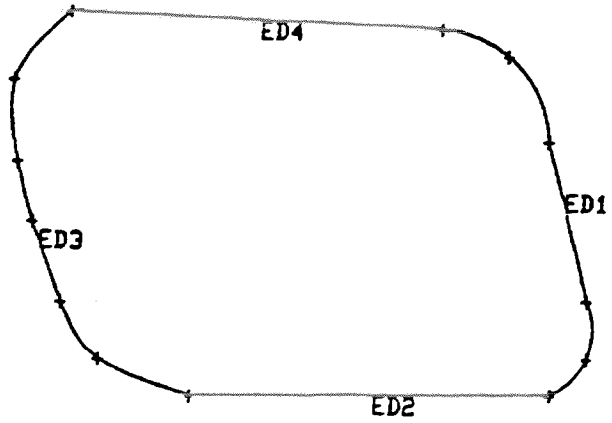

**MESH GENERATION**

**SURFACE MESH  
NODES ON MESH  
NODES AND ELEMENTS  
ON MESH**

**SURFACE MESH**

**CREATE  
PARAMETER  
SKETCH  
LABEL  
LIST  
PURGE  
NODE PARAMETER  
ELEMENT PARAMETER**

**LABEL  
INCREMENT  
COLOR  
LINE STYLE  
STATUS**

**LABEL  
COLOR  
LINE STYLE  
CURRENT GROUP**

**SOLID  
DASHED**

**NODES ON  
MESH**

**NODES AND ELEMENTS  
ON MESH**

**LABEL  
INCREMENT  
DEFINITION COORDINATE  
SYSTEM  
DISPLACEMENT COORDINATE  
SYSTEM  
COLOR  
GENERATION SYSTEM  
STATUS**

**LABEL  
INCREMENT  
TYPE  
PROPERTY REFERENCE  
MATERIAL REFERENCE  
COLOR  
STATUS**

SURFACE\_MESH\_CREATE  
MID\_BIAS

