

DESIGN OF HIGH PRECISION SANDWICH STRUCTURES USING ANALYTICAL AND FINITE ELEMENT MODELS

Dr. W. Elspass

Institute for design and construction methods
Swiss Federal Institute of Technology (SFIT) Zurich
Raemistr. 101, CH-8092 Zurich

presented at
MSC World User's Conference
Los Angeles, California
March 26-30, 1990

Contents

Design of high precision sandwich structures using analytical and finite element models	1
1. Abstract	1
2. Introduction	2
3. Honeycomb and sandwich models	3
3.1 Analytical honeycomb model	3
3.2 Sandwich finite element model	6
3.3 Results	7
4. Prediction of contour accuracy for sandwich panels with parabolic shape using finite element models	10
5. References	14

Tables

1. Elastic constants of honeycomb 3/16-5056-.001	8
--	---

Figures

1. Definition of honeycomb coordinate system	1
2. Components of a sandwich plate with faceskins of composite material	2
3. Geometric parameters of the honeycomb	3
4. Beam model of the representative portion of the honeycomb	3
5. Deformed shapes of honeycomb	6
6. Detailed 3-D finite element model	7
7. Scale factor concerning faceskin stiffness	9
8. Scale factor concerning core thickness	9
9. Deformed shape of a 30 mm thick honeycomb	10
10. Idealization of a honeycomb sandwich panel	11
11. Definition of reference geometry for calculation of the contour error	12
12. Isocontours of z-displacements for honeycomb core with and without in-plane stiffness	13

Design of high precision sandwich structures using analytical and finite element models

1. Abstract

Composite sandwich structures must be carefully designed to meet very close thermal distortion tolerances such as those required for structures like communication satellite antennas or reflectors of terrestrial systems.

To analyze and optimize the design of high precision sandwich structures it is necessary to know the complete thermoelastic material property data of all components. The properties of faceskin material are fairly well documented and can be used with confidence, however the properties of the core material are less well known. The material elasticity data of the honeycomb core material provided by the manufacturer are the transverse shear moduli G_{xy} , G_{yz} and the orthogonal modulus E_z .

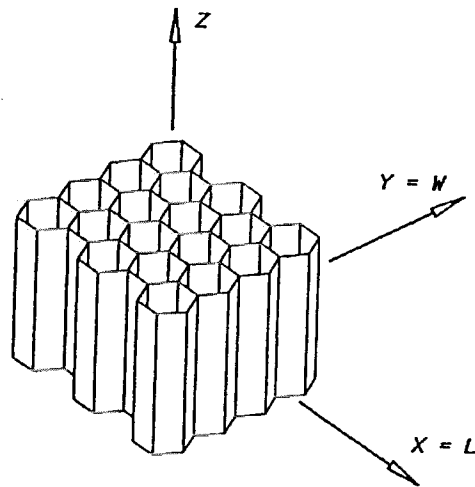

Figure 1. Definition of honeycomb coordinate system

For that reason analytical and finite element models have been developed to determine the thermoelastic constants of honeycombs as an orthotropic homogeneous material.

Also the influence of certain parameters as core weight density, faceskin stiffness and core height on the elastic constant of the honeycomb is taken into consideration. Besides several tests were performed to verify the theoretical results.

As honeycomb is regarded as a homogeneous orthotropic material, it can be modelled with the knowledge of all 9 elastic constants by use of solid elements in finite element analysis. This procedure simplifies the analysis of sandwich structures thus improving the accuracy concerning the inplane ¹ stiffness of the core material.

To quantify the influence of different material combination for core and facesheets, parametric studies are performed with a special finite element reference structure. For selected thermal load cases the deformations of a sandwich with parabolic shape are analyzed by calculating the contour error.

2. Introduction

Spacecraft components require the use of lightweight materials that are dimensionally invariant with respect to temperature changes, to achieve and maintain dimensional accuracy. Advanced composite materials even in combination with metallic honeycomb material result in sandwich components which meet the requirements of high stiffness and minimum weight while providing the capability of achieving a near-zero coefficient of thermal expansion (CTE) over quite a wide temperature range. These properties are most useful to future, high frequency communications satellite antenna reflectors, where deviations from the ideal contour must be held to fractions of a millimeter under all operating environmental conditions of space.

To predict the thermoelastic behavior of a sandwich component with high accuracy, it is necessary to consider all relevant components and their influence on the overall behavior. Figure 2 shows the complexity of a sandwich from this point of view.

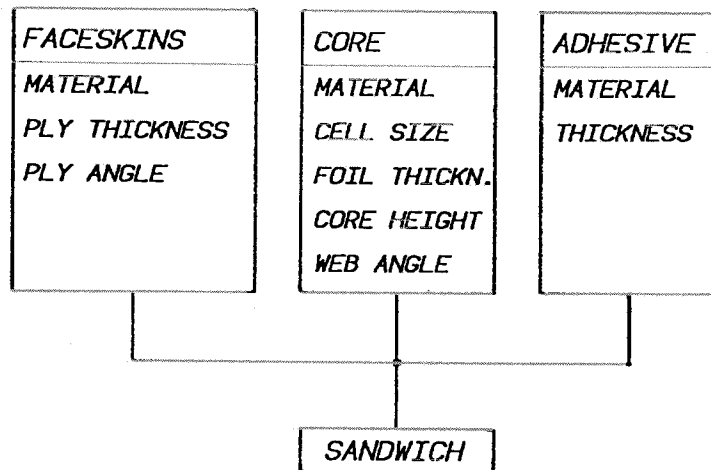

Figure 2. Components of a sandwich plate with faceskins of composite material

¹ in-plane: in the xy-plane

Design of high precision sandwich structures using analytical and finite element models

1. Abstract

Composite sandwich structures must be carefully designed to meet very close thermal distortion tolerances such as those required for structures like communication satellite antennas or reflectors of terrestrial systems.

To analyze and optimize the design of high precision sandwich structures it is necessary to know the complete thermoelastic material property data of all components. The properties of faceskin material are fairly well documented and can be used with confidence, however the properties of the core material are less well known. The material elasticity data of the honeycomb core material provided by the manufacturer are the transverse shear moduli G_{xy} , G_{yz} and the orthogonal modulus E_z .

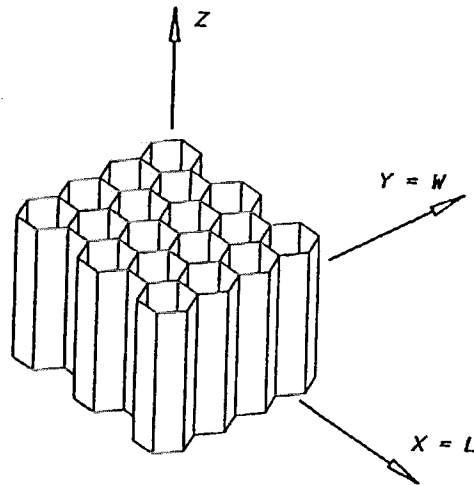

Figure 1. Definition of honeycomb coordinate system

For that reason analytical and finite element models have been developed to determine the thermoelastic constants of honeycombs as an orthotropic homogeneous material.

Also the influence of certain parameters as core weight density, faceskin stiffness and core height on the elastic constant of the honeycomb is taken into consideration. Besides several tests were performed to verify the theoretical results.

3. Honeycomb and sandwich models

3.1 Analytical honeycomb model

To determine the in-plane stiffness of the honeycomb, first of all, a simple analytical model on the basis of the classical beam theory was developed. Because of the symmetry of the honeycomb geometry only a portion of the structure has to be considered. Figure 3 represents the geometry parameters of the honeycomb.

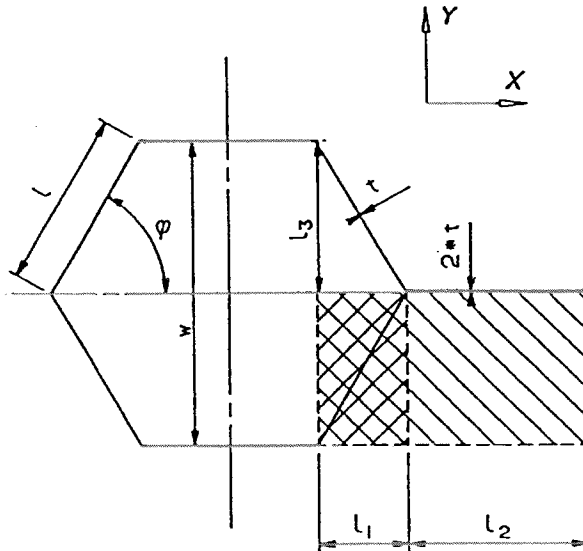

Figure 3. Geometric parameters of the honeycomb

To determine the elastic constants $E_x, E_y, G_{xy}, \nu_{xy}$ the problem is reduced to a 2D bending problem. It is assumed that the double thickness webs ($2*t$) do not bend because of the symmetry of the honeycomb cells. Furthermore the web angle φ does not change in the deformed state.

A schematic representation of the analytical model is given in Figure 4.

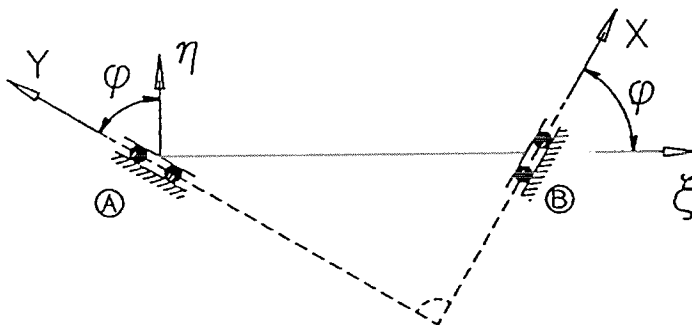

Figure 4. Beam model of the representative portion of the honeycomb

A local cartesian η, ξ -coordinate system is introduced to formulate the differential equation with respect to the boundary conditions under in-plane loading in x- and y-direction and shear load in the xy-plane.

In the following the procedure to determine E_x is shown. The other constants E_y, G_{xy} and ν_{xy} are calculated in a similar way.

Due to the kinematic boundary conditions the displacement u (ξ -direction) and w (η -direction) at supports A and B can be expressed as:

$$w_A = \frac{1}{\tan \varphi} u_A$$

$$w_B = -\tan \varphi u_B$$

The force acting in x-direction F_x is reduced with respect to the local coordinate system:

$$F_\eta = -F_x \sin \varphi = N_x$$

$$F_\xi = F_x \cos \varphi = Q_x$$

By integrating the components u and w of the displacement is obtained:

$$w = \frac{1}{6} c_1 \xi^3 + \frac{1}{2} c_2 \xi^2 + c_3 \xi + c_4$$

$$u = c_5 \xi + c_6$$

Considering the boundary conditions, the constants c_1 to c_6 are determined:

$$c_1 = -\frac{Q_x}{EI}$$

$$c_2 = \frac{1}{2} \frac{Q_x l}{EI}$$

$$c_3 = 0$$

$$c_4 = -\frac{\frac{N_x l}{EA} \tan \varphi - \frac{1}{12} \frac{Q_x l^3}{EI}}{1 + \tan^2 \varphi}$$

$$c_5 = \frac{N_x}{EA} = \varepsilon$$

$$c_6 = \tan \varphi c_4$$

To calculate the x-component of the strain, the displacements must be transformed back to the global xy-coordinate system:

$$U = u \frac{1}{\cos \varphi}$$

$$W = w \frac{1}{\cos \varphi}$$

In addition to the contribution of section 1, the tensile strain of section 2 has to be taken into account:

$$U_{x2} = \frac{F_x}{2 E A} l_2$$

The equivalent Young's modulus E_x is expressed by

$$E_x = \frac{\sigma_x}{\varepsilon_x}$$

with

$$\varepsilon_x = \frac{U_{x1}(\xi = l) + U_{x2}}{l_1 + l_2}$$

and

$$\sigma_x = \frac{F_x}{l_3 t_c}$$

With this simple model the behavior of the honeycomb far away and near the faceskins can be investigated. Far away from the faceskins, the single thickness members deform in a cubic shape. However near the faceskins only a tensile deformation of the webs is permitted by the much stiffer faceskins. This restrained state of deformation can be simulated in the analytical model by setting all nonlinear terms in the differential equation to zero (see Figure 5 on page 6).

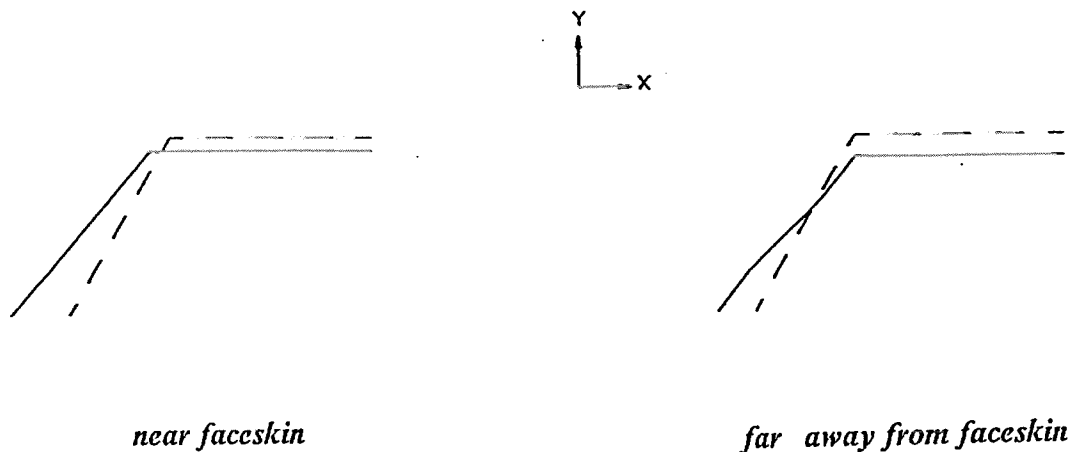

Figure 5. Deformed shapes of honeycomb

3.2 Sandwich finite element model

Because the core in-plane stiffness is mainly a geometrical one (i.e. heavily depends on the boundary conditions (faceskin stiffness), and to consider the influence of the core height t_c on the in-plane elastic constants of the honeycomb), a detailed 3D-model of a sandwich was developed.

The symmetry about the xy -plane only requires half of the structure to be idealized while suppressing the corresponding degrees of freedom in z -direction in the symmetry plane. In this model the webs and faceskins are idealized by using QUAD4 and TRIA3 elements.

It should be noted that the stiffness of the adhesive layers are taken into account in that of the faceskins by assuming the adhesive as an additional layer of the faceskin laminate. The concave fillet weld between the webs and the faceskins is modeled by truss elements (CONROD).

To facilitate and speed up the high amount of input data a special pre-processing routine has been developed to generate a complete data set for the fe-analysis of a sandwich plate. This was easily done by using "program file utility" in the IDEAS-SUPERTAB pre-processor. To obtain the complete sandwich model the following input data are necessary:

- cell size of the honeycomb
- number of cells in x -, y -direction
- core thickness
- foil thickness

The number of elements of the webs and the faceskins can also be defined in detail. For the other input data as for example the material data of the core and the faceskins, default values are set to consider an aluminum honeycomb core with faceskins of CFRP-laminate (isotropic lay-up). Of course also anisotropic type of material can be defined for the core and the faceskins. Moreover the loading, supports and constraints are automatically set by the program referring to the selected load case (thermal or mechanical loads).

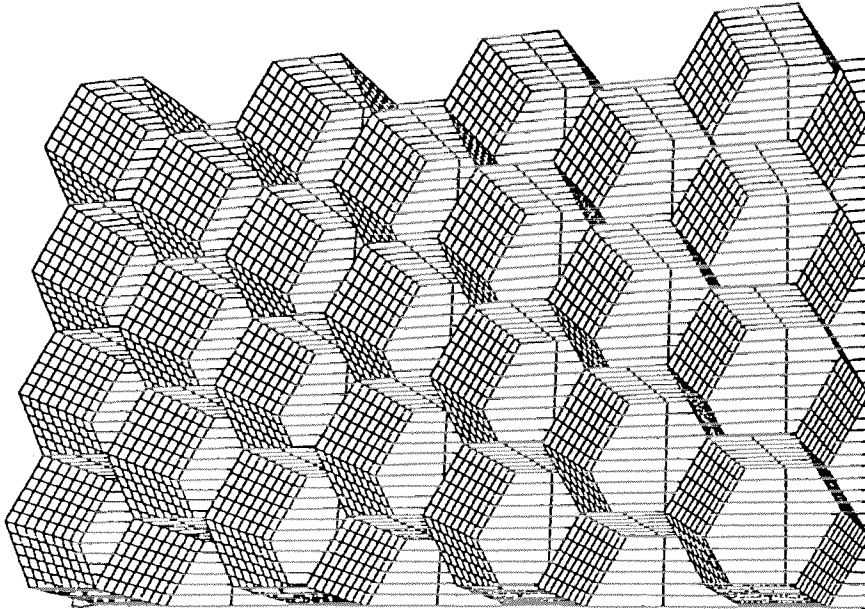

Figure 6. Detailed 3-D finite element model

The postprocessing of the results, i.e. the calculation of the equivalent elastic constants is also done by using a program file routine. The approach is completely the same as for the analytical model.

3.3 Results

In Table 1 on page 8 the results are summarized for a honeycomb type 3/16-5056-.001² with a core thickness of $t_c = 1 \text{ mm}$ and a rigid faceskins. Regarding the in-plane elastic constants in the xy-plane the influence of the faceskins is obvious. The Young's modulus E_x for the honeycomb near the faceskins is increased by a factor of 3000 compared with the behavior far away from it. This increase of stiffness is forced by the restrained bending deformation of the webs. Also the Poisson's ratio decreases from $\nu_{xy} = 0.99$ to $\nu_{xy} = 0.28$ at the same time. Moreover the Young's modulus in direction of the double thickness webs E_x is about 35 % higher than the corresponding in y-direction for the elastic honeycomb behavior near the faceskins. At this point it can already be stated that there must be a dependency of the core thickness on the in-plane elastic constants.

² 3/16: cell size in fractions of an inch; 5056: type of aluminum alloy; .001: nominal foil thickness in inches

Also it can be stated that the results of the analytical and the finite element model showed a good correspondence.

Tests of sandwich specimen measuring the in-plane Young's moduli confirmed the above results within a deviation of 8 %.

	far away from faceskin	near faceskin
$E_x [N/mm^2]$	0.127	415
$E_y [N/mm^2]$	0.127	267
$E_z [N/mm^2]$	996	996
$\nu_{xy} []$	0.99	0.29
$\nu_{xz} []$	0.30	0.30
$\nu_{yz} []$	0.30	0.30
$G_{xy} [N/mm^2]$	0.87	131
$G_{xz} [N/mm^2]$	192	192
$G_{yz} [N/mm^2]$	287	287

Referring to this type of honeycomb the influence of the following parameters on the honeycomb elastic constants was quantified:

- faceskin stiffness $E_f t_f$
- core height t_c
- angle between webs φ

The honeycomb parameters cell size and foil thickness can be summarized in the parameter core eight density. It is clear that the increase of core weight density means a proportional increase of honeycomb stiffness.

Concerning the faceskin stiffness this parameter was changed within technical reasonable limits while keeping the core unchanged. The limits represent the stiffness of CFRP faceskin material available now (from high tensile T-300 to ultra high modulus GY-70 laminate). The faceskins are assumed to have a quasi isotropic lay-up. As a basic result it turned out that the in-plane stiffness constants of the honeycomb with a faceskins stiffness $E_f = 260 \text{ kN/mm}$ are about 35 % higher than one with $E_f = 20 \text{ kN/mm}$ (Figure 7 on page 9).

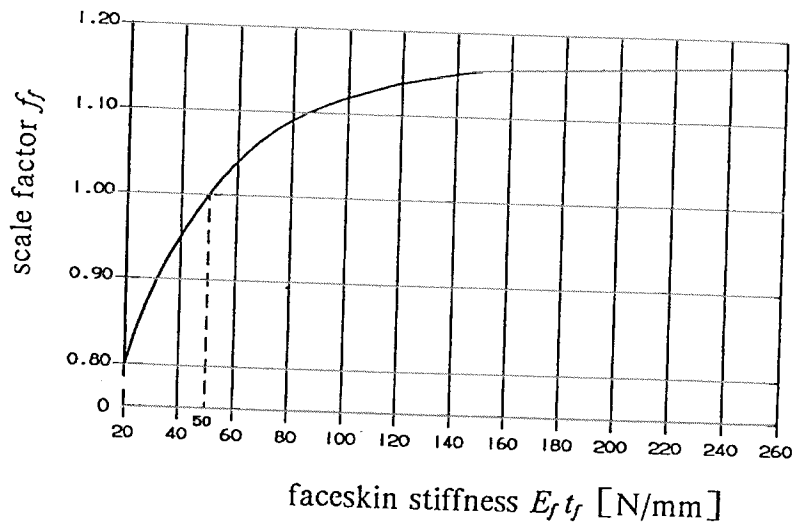

Figure 7. Scale factor concerning faceskin stiffness

Another important influence parameter is the web angle φ . In practical work one will never find a perfect honeycomb with $\varphi = 60^\circ$. The analysis shows that a change of $\Delta\varphi = 5^\circ$ results in a maximum change of 30 % referring to the Poisson's ratio ν_{xy} of the ideal geometry.

To evaluate the effect of the core thickness this parameter was varied within a range $2 \text{ mm} < t_c < 50 \text{ mm}$ while keeping the faceskins unchanged. It turns out that the faceskins only restrain a narrow edge zone of the honeycomb, i.e. only up to a thickness of approximately $t_c = 5 \text{ mm}$ the honeycomb core fully contributes to the overall (smeared) lateral stiffness of the sandwich. For increasing core thickness the equivalent stiffness contribution of the honeycomb drops as the honeycomb can deform without restraint. Therefore a honeycomb with a thickness $t_c = 50 \text{ mm}$ only contributes 28 % of the in-plane stiffness of one with a thickness $t_c = 5 \text{ mm}$ (Figure 8).

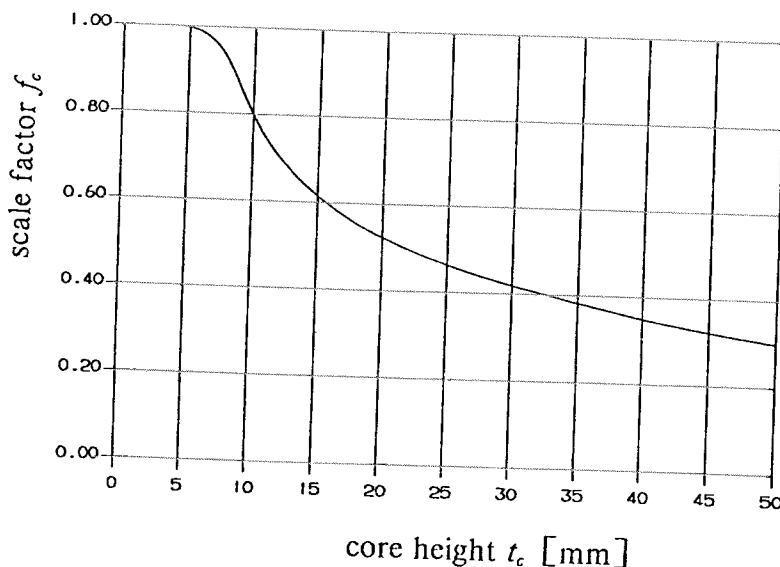

Figure 8. Scale factor concerning core thickness

The deformation of one cell of a honeycomb with $t_c = 30$ mm is shown in Figure 9 on page 10.

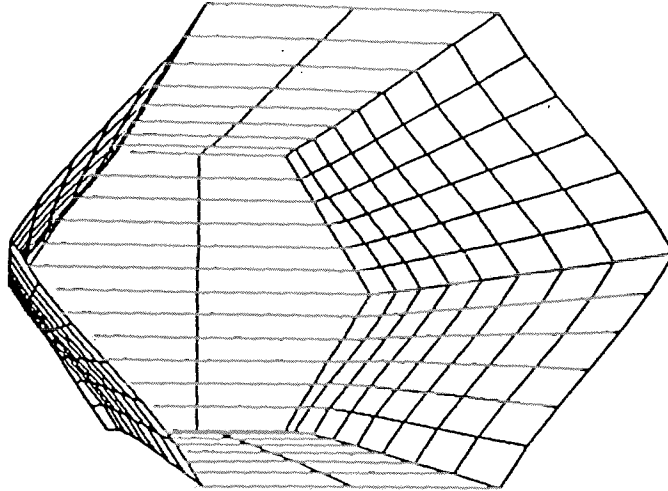

Figure 9. Deformed shape of a 30 mm thick honeycomb

Additional runs loading the sandwich model with a global temperature rise confirmed the CTE's of the sandwich in the xy-plane calculated with laminate theory using the equivalent thermoelastic data of the core. Concerning the resulting CTE of the sandwich in z-direction however, a strong effect of the Poisson's ratio of the honeycomb has to be noticed. It is found that the CTE_z of the sandwich is about 30 % higher than that of the core material. The reason for this effect is the much more higher facesheet stiffness (factor 100 - 500) and the less CTE (factor 8 - 30) compared with the core. Under thermal loading the facesheets restrain the in plane expansion of the core where the core has to expand more in the orthogonal direction because of the lateral contraction (Poisson's ratio).

The influence of different parameters on the elastic constants of the honeycomb has been quantified. So it is possible to convert the data of the master core listed in Table 1 on page 8 to any other sandwich configuration.

4. Prediction of contour accuracy for sandwich panels with parabolic shape using finite element models

With the knowledge of the detailed set of material constants an improved analysis of sandwich structures can be performed by fe-analysis. Thus a precise prediction of sandwich behavior under such loads as i.e.

- manufacture
- temperature fields
- humidity
- gravity

is enabled. Figure 10 on page 11 shows the element types used for the analysis of an antenna reflector panel with CFRP faceskins and an aluminum honeycomb core. The honeycomb core is modelled by volume elements with orthotropic material law (HEXA, MAT9/ MATT9), thus using plate elements for the faceskins (QUAD4, MAT8/ MATT8).

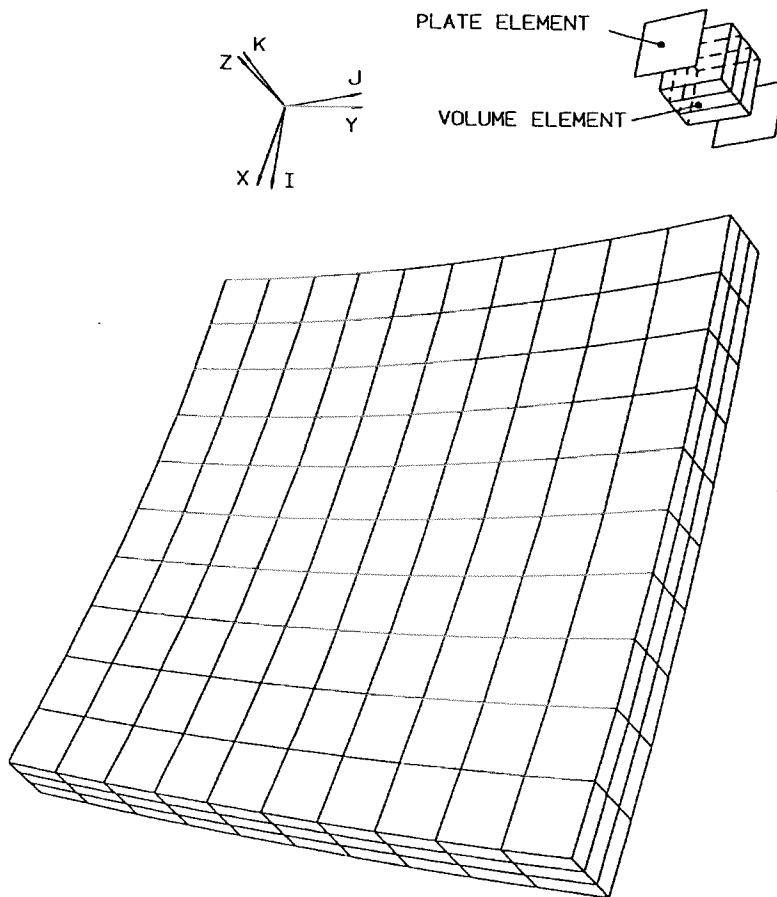

Figure 10. Idealization of a honeycomb sandwich panel

To determine the accuracy of parabolic shaped contour it is required to compare the deformed paraboloid either with the undeformed ideal or with a best fitted paraboloid by changing the paraboloid parameters as location of the apex, orientation of the paraboloid axes or the focal length. So the minimum contour error is obtained. The result is the root mean square of the vertical distances v_i from a point of reference to the deformed contour.

- — — — — undeformed contour
- - - - - deformed contour
- bestfit contour

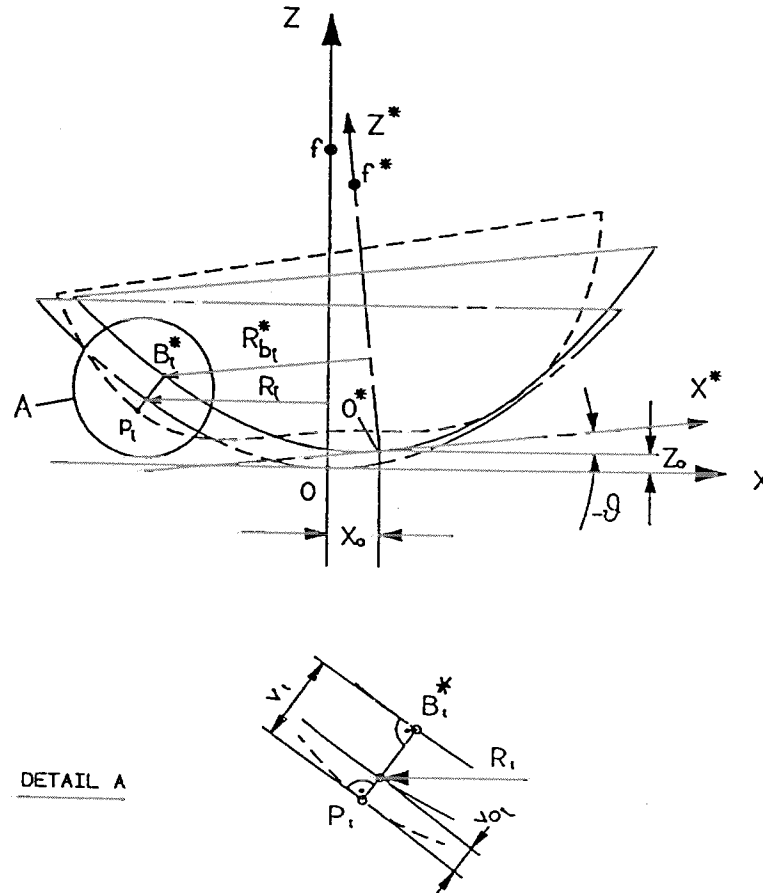
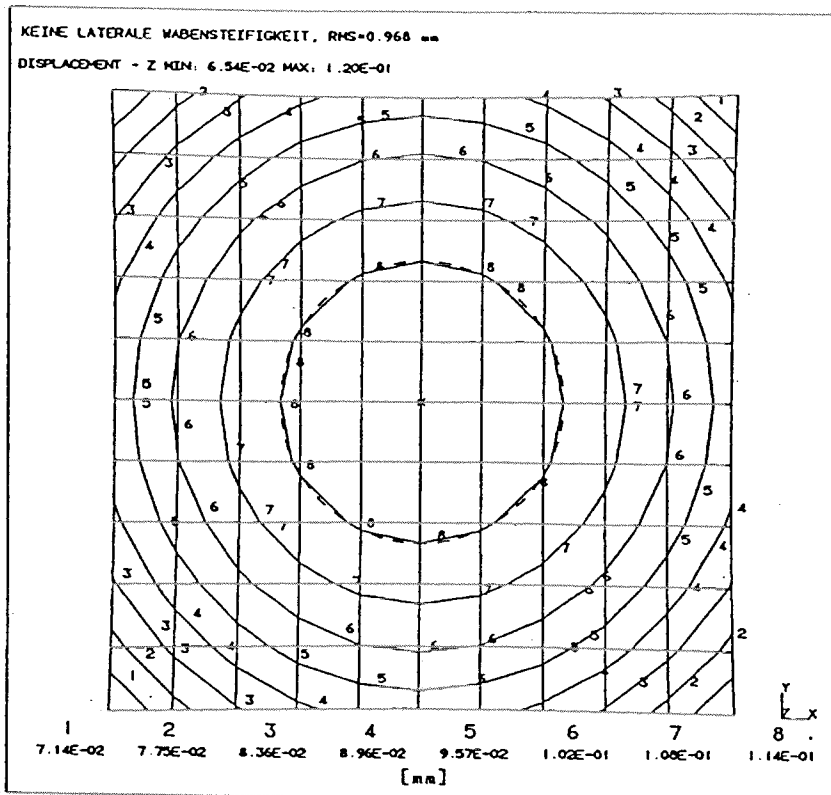

Figure 11. Definition of reference geometry for calculation of the contour error

To estimate the error, if the in-plane stiffness of the honeycomb core material is neglected, analyses using the above model (see Figure 10 on page 11) under different thermal loading (global temperature rise of the entire structure, thermal gradient through the thickness of the sandwich) were performed. The essential result is that the neglecting of the core in plane stiffness leads to errors up to 60 % (referring to rms contour accuracy) compared with the real behavior of the core, i.e. having orthotropic in-plane stiffness.

This result can be clarified if the isocontours of displacements in z-direction (in direction of the paraboloid axis) are plotted for both cases (Figure 12 on page 13).



A. no in-plane core stiffness

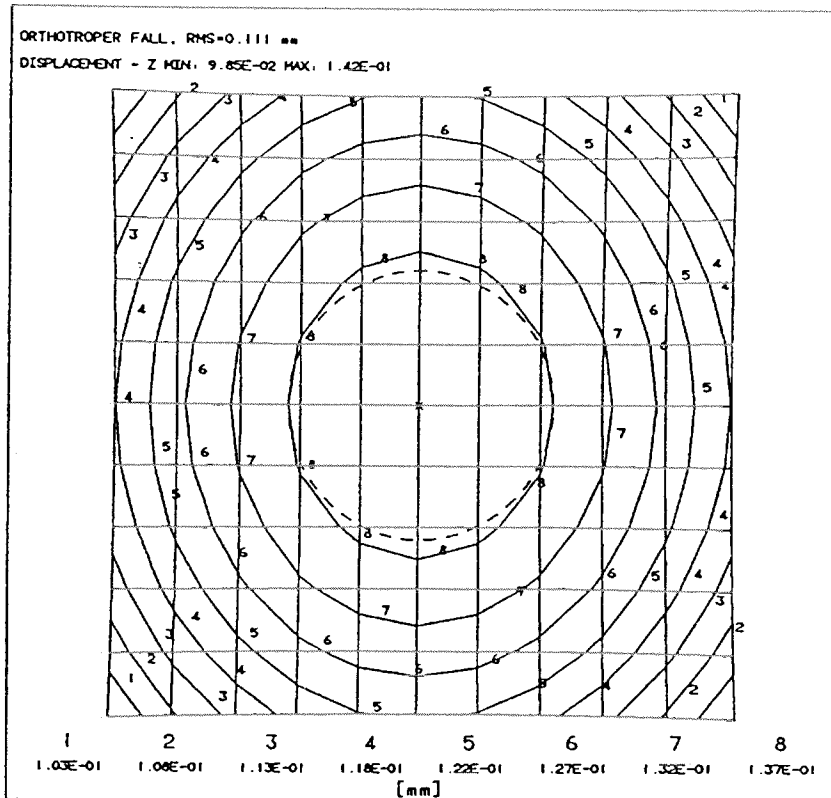

B. orthotropic in-plane core stiffness

Figure 12. Isocontours of z-displacements for honeycomb core with and without in-plane stiffness

It is obvious that the orthotropic in-plane stiffness of the core changes the undeformed spherical paraboloid to an elliptical in the deformed state.

Experimental tests have turned out that the deviation of the calculated and measured thermal deformations of a corresponding sandwich specimen are less than 10 % max.

So it can be concluded that this analysis procedure is a very useful tool to predict the deformation behavior of sandwich components under thermal loading with high accuracy.

5. References

1. L.J. Gibson, M.F. Asby

Cellular Solids, Structure and properties, Pergamon Press 1988

2. W. Elspass

Thermal stable sandwich structures, PhD thesis, Swiss Federal Institute of Technology Zurich, 1989