

Implementation and Verification of a Coupled Fire Model as a Thermal Boundary Condition Within P3/Thermal

D. M. Hensinger, L. A. Gritzko, and J. A. Koski

Sandia National Laboratories

Albuquerque New Mexico 87185-5800

Abstract:

A user-defined boundary condition subroutine has been implemented within P3/THERMAL to represent the heat flux between a non-combusting object and an engulfing fire. The heat flux calculation includes a simple two dimensional fire model in which energy and radiative heat transport equations are solved to produce estimates of the heat fluxes at the fire-object interface. These estimates reflect the radiative coupling between a cold object and the flow of hot combustion gasses which has been observed in fire experiments. The model uses a database of experimental pool fire measurements for far field boundary conditions and volumetric heat release rates. Taking into account the coupling between a structure and the fire environment is an improvement over the σT^4 approximation frequently used as a boundary condition for engineered system response and is the preliminary step in the development of a fire model with a predictive capability. This paper describes the implementation of the fire model as a P3/THERMAL boundary condition and presents the results of a verification calculation carried out using the model.

Introduction

An engulfing fire is one of the many hypothetical accident scenarios to be considered when assessing the fire survivability of systems such as hazardous material shipping containers. Such a fire could occur as a result of a transportation accident. The ability to represent the fire environment, and the coupled thermal response of the fire environment and a shipping container is an integral part of the design and assessment of these engineered systems. The ability to use the Container Analysis Fire Environment (CAFE) code as a P/THERMAL option represents an important achievement in the continuing development of tools that can be used by hazardous material shipping container analysts and designers. This is because it is a first step in capturing the influence of a non-combusting object on an engulfing fire.

Code Physics

The CAFE code was developed based on the gray gas model of Nicolette and Larson [1]. The goal of the CAFE model is to provide a thermal boundary condition representing an engulfing pool fire for hazardous material container thermal response models. The use of detailed fire field models in conjunction with high-fidelity thermal response models of hazardous material containers is presently intractable due to the difficulty of code and solution integration. Accordingly, the CAFE models employ a simplified deterministic formulation of the dominant physics to provide an improved estimate of the incident heat flux (relative to a simple σT^4 boundary condition) to an engulfed object. In the CAFE code, it is assumed that hot combustion gas, which is initially at a temperature T_f , travels over a surface of length L at a constant, uniform velocity, u_∞ . Convective heat transfer between the gas and the surface are represented using a standard turbulent flow correlation based on u_∞ and the properties of the combustion gas. Viscous boundary layer effects are neglected since the viscous boundary layer thickness is small (on the order of 0.05 m) as compared to the extent of the temperature field required to model thermal radiation in the participating media (on the order of 1.0 m). The combustion gas is modeled as a nonconducting, uniform concentration participating media at a constant and uniform pressure with a constant or Arrhenius-type volumetric source term representing combustion. The combustion gas and soot are treated as a single, volume averaged, absorbing and emitting mixture. The gas density varies with temperature according to the ideal gas law. The remaining properties of the gas are taken as constant. A two-flux method is used to model the radiative transfer in a direction normal to the surface. The necessary subroutines have been developed to represent scattering and gray surfaces, but the present version includes only absorbing and emitting media and black surfaces.

Presently the temperature distribution at the leading edge (i.e. the initial temperature) is supplied by the FIRETEMP thermocouple temperature database developed by Joe Mansfield based on a series of spill fire tests [2]. This database provides the temperature distribution from the leading edge of the surface (i.e. the center of the lowest point on the surface) for a distance of 5 optical paths along a vector normal to the surface. The database requires wind and pool size (given in the form of fuel spill rate) information as input data. Data with improved fidelity is presently available for use for scenarios without wind. Efforts are currently being devoted to the development of a model which predicts this temperature distribution.

Coupling Implementation

The fire model and P/THERMAL are coupled through the ULIB subroutine framework supplied with P/THERMAL. These subroutines are called at key points during P/THERMAL execution. Figure 1 is a flow chart of the original unmodified P/THERMAL solution process showing the ULIB subroutines called during solution. To implement the CAFE model within P/THERMAL, additional subroutines were added to the ULIB subroutines. The fire code calculations were carried out within these subroutines. Figure 2 is a flow chart showing the subroutines added to implement the CAFE model within P/Thermal.

Thermal calculations using P/THERMAL and the fire boundary condition proceed in the following manner (referring to Figure 2). Initialization of variables is carried out in the subroutines called from Init1 and Init2. GGIN.DAT, SETPROP.DAT, and TAX.# are five data files which contain constants relevant to problem geometry, material properties, and fire conditions. At each time step, subroutine ULOOP1 calls the following subroutines: Reset, Bound, Step, and FlxRet. Subroutine Reset reinitializes variables before each solution of the fire temperature and flux profile. Subroutine Bound and the subroutines it calls map the temperature profile from the surface in contact with the fire onto the grid used by the fire calculation. These temperatures are one of the boundary conditions for the fire field calculation. Within subroutine Step, the fire field grid is iteratively solved for its steady state temperature and heat flux distribution. After the fire field calculation has converged, subroutine FlxRet calculates the radiant flux field at the boundary of the fire field (q''). This calculated value is applied to the thermal model to represent the fire boundary condition. The heat flux calculated in FlxRet is used, inside subroutine UHVAL, to calculate an equivalent heat transfer coefficient (h) at each node using the expression given in Equation 1, where T_1 is the surface temperature and T_2 is the far field fire temperature. Within P/THERMAL, the values of h , T_1 , and T_2 are recombined to apply the appropriate heat flux boundary condition to the surface exposed to the fire boundary condition.

$$h = \frac{\dot{q}''}{T_1 - T_2} \quad (\text{EQ 1})$$

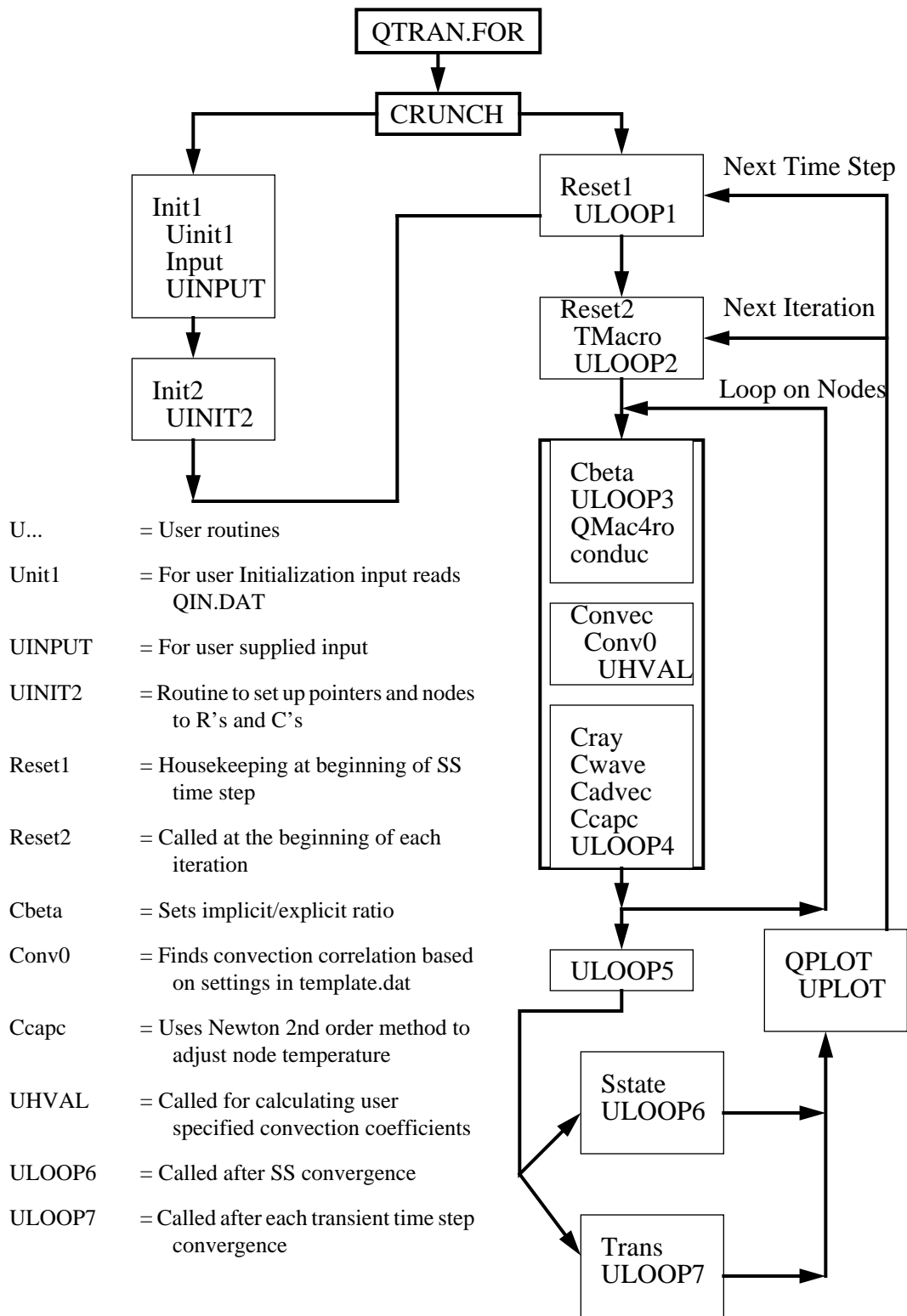

Figure 1. Top level P/THERMAL Flow Diagram from [3].

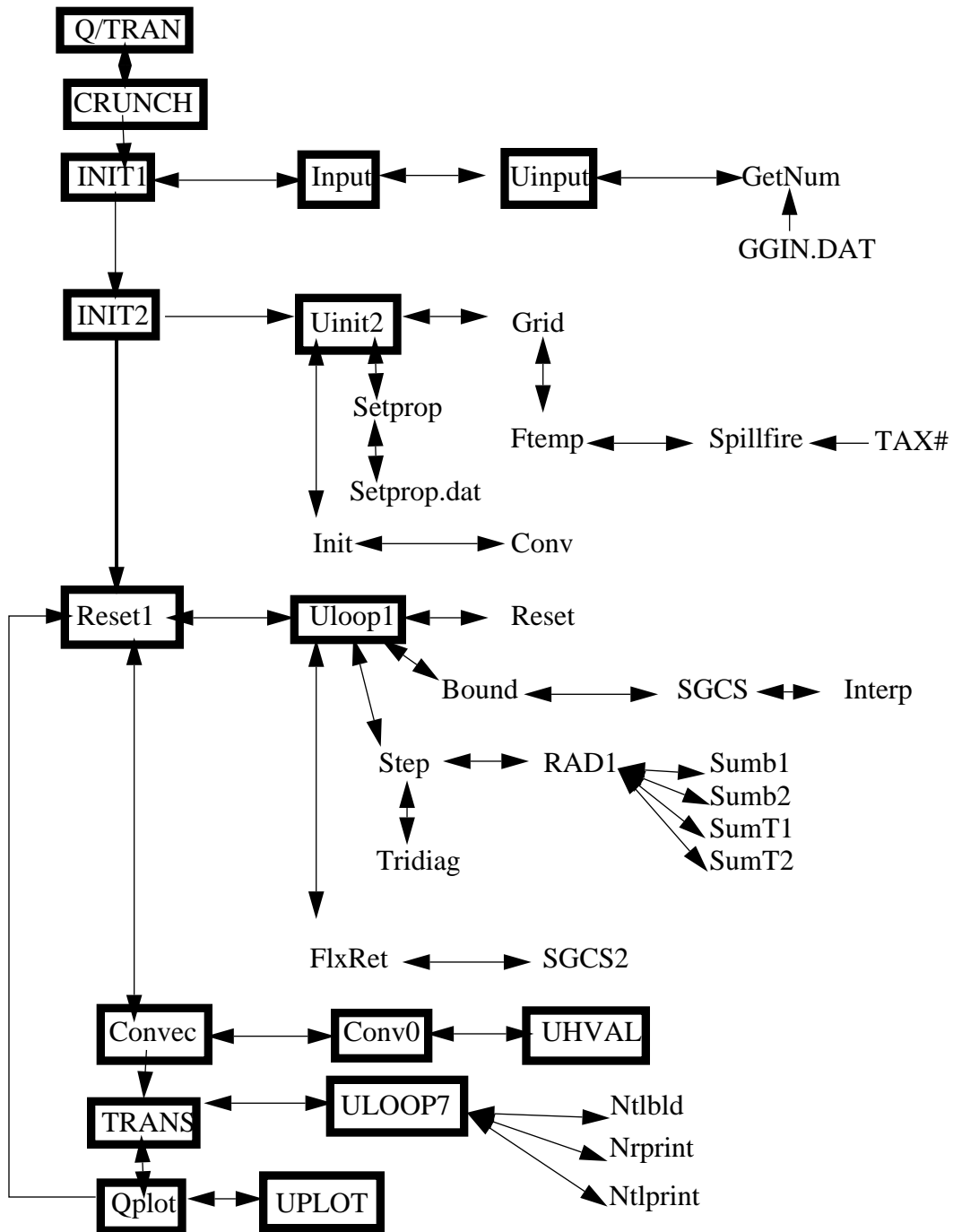

Figure 2. Flow chart of implementation of CAFE code within ULIB subroutines.

Verification

The correct implementation of the fire boundary condition within the P/THERMAL analysis code was verified by modeling a transient fire-structure interaction problem within P/THERMAL for

which a separate solution was available. The geometry of the test problem was a slab with a thickness (w) of 0.004 m, a width of 1.0 m, and a height (L) of 3.0 m. The fire boundary condition was applied to one face of the slab with the fire free stream direction oriented in the L direction. All other surfaces were insulated. The slab had the following material properties:

1. The initial slab temperature (T_{iw}) was 318.25 K.
2. The thermal conductivity of the slab (k) was 50 W/mK.
3. The slab density (ρ) was 100 kg/m³.
4. The slab specific heat (c_p) was 100 KJ/kg K.

The fire environment was characterized by the following conditions which are typical of a large hydrocarbon pool fire:

1. The gas absorption coefficient (a) was 4.6 m⁻¹.
2. The far field density of the fire (ρ_f) was 0.27 kg/m³.
3. The gas specific heat (c_{pf}) was 1180 J/kg K.
4. The far field temperature in the fire (T_f) was uniform and equal to 1273 K.
5. The free stream velocity (u_∞) was 5.0 m/s.

Both analyses included the following assumptions:

1. There is no convective heat transfer between the slab and the fire.
2. Radiative heat transfer is negligible in the free stream direction.

The results of this calculation were compared to a separate solution of the same problem given in Reference 4. This analysis consisted of a solution of conduction within the slab using a 1-D finite difference model with the fire field supplying a heat flux boundary condition.

The results of the analysis of Reference 4 and the P/THERMAL simulation performed here are presented in terms of the following nondimensional groups:

$$\tau = \frac{kt}{\rho c_p w^2} \quad (\text{EQ 2})$$

$$Bi_{rad} = \frac{\sigma T_f^3 w}{k} \quad (\text{EQ 3})$$

$$N_{rad} = a \frac{L}{Bo} \quad (\text{EQ 4})$$

Where Bo is defined by:

$$Bo = \frac{\rho_f c_{pf} \mu_\infty}{\sigma T_f^3} \quad (\text{EQ 5})$$

The net heat flux to the plate surface, averaged over the length, normalized by the incident black body flux (σT_f^4), from the P/THERMAL solution and Reference 4 is shown in Figure 3.

For this typical case of coupling between a fire and a solid object, agreement is observed between the two solutions. The difference between the two calculations may be due to the finite conductivity in the streamwise direction allowed in the P/THERMAL model compared to the zero thermal conductivity imposed in this direction in the solution of Reference 4.

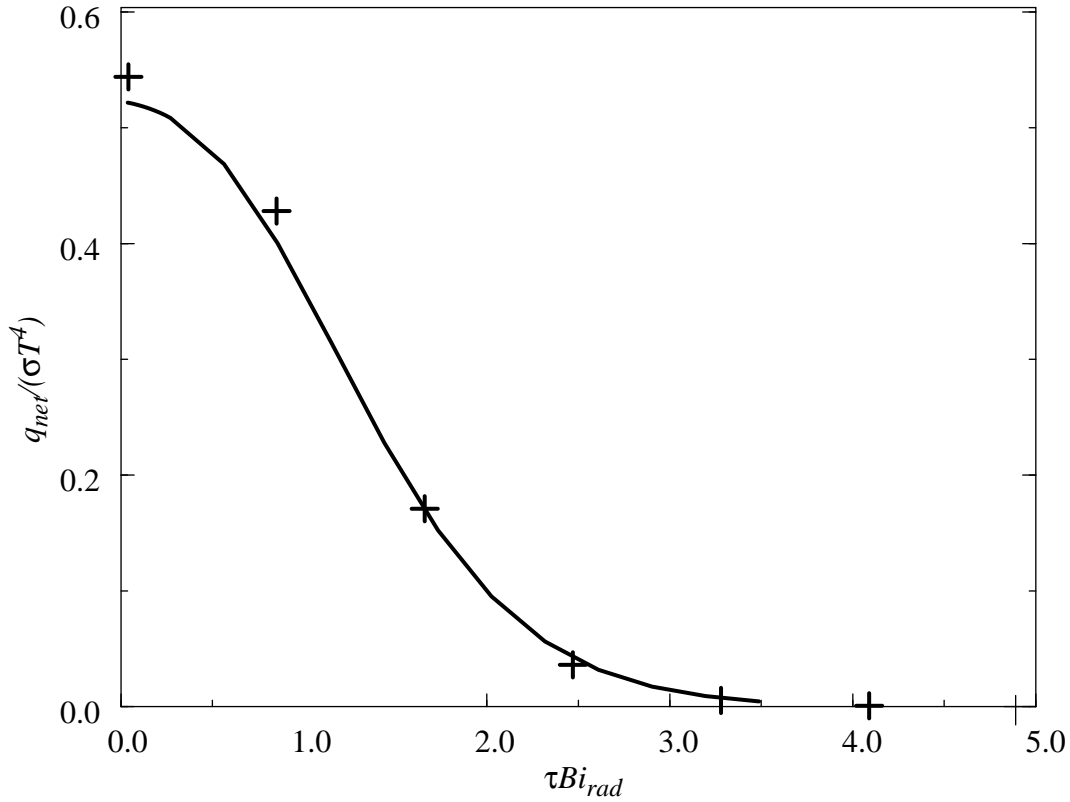

Figure 3. Comparison of results from P/THERMAL coupled with the CAFE code (solid line), to results from Reference 4 (Symbols). Transient nondimensional average heat flux for $T_{iw}/T_f = 1/4$, $Bi_{rad} = 0.1$, and $N_{rad} = 1.0$.

Results

Figures 4, 5, and 6 are fringe plots for the coupled P/THERMAL and fire code solution used to verify the correct implementation of the CAFE code as a P/THERMAL option. Each plot corresponds to conditions at a time 0.5 seconds after the slab was first exposed to the fire. Figure

4 shows the temperature profile in the slab. The highest temperatures are at the base (leading edge) of the slab where the fire has not yet been cooled by exposure to the slab. Farther along the slab surface in the streamwise direction the lower temperatures reflect the lower heat flux from the fire, due to cooling of the participating media in the fire from exposure to the lower portions of the slab. Figure 5 shows the temperature profile in the fire grid. The surface temperature of the slab is imposed on the left hand side of this grid as a boundary condition for solution of the fire field. Figure 6 shows the divergence of the radiative heat flux calculated within the fire grid. The heat fluxes are nonzero along the edge of the fire grid which is coupled to the slab. The temperature gradients near the slab's leading edge result in locally increased heat fluxes in this region.

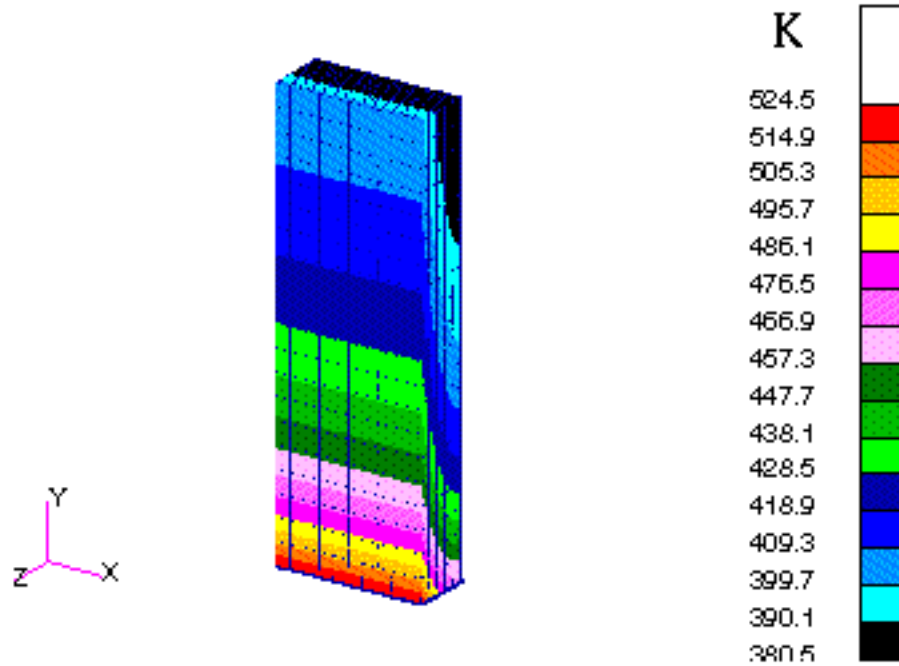

Figure 4. Temperature profiles in a 0.004 m thick by 3 m long slab initially at 318.25 K after simulated exposure to a 1273 K fire for 0.5 seconds.

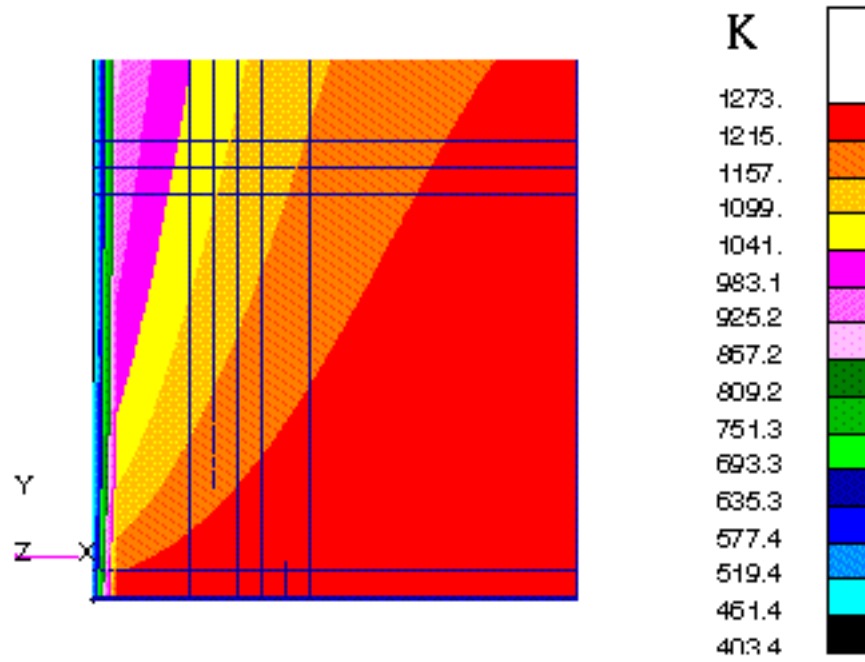

Figure 5. Temperature profiles within the fire grid.

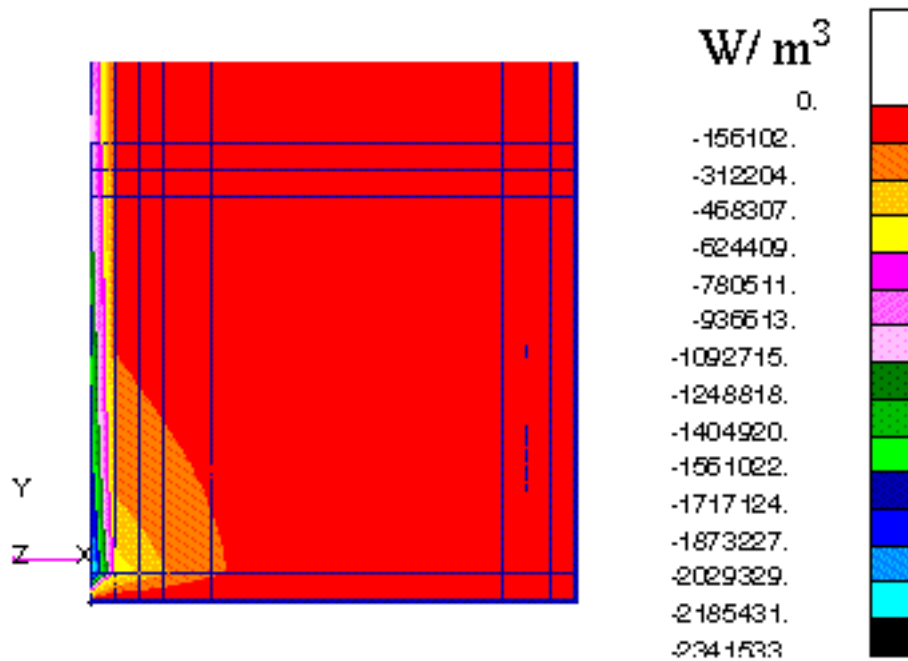

Figure 6. Divergence of the radiant heat flux in the fire grid.

Conclusions

The CAFE model has been implemented as an optional boundary condition in P/THERMAL. This boundary condition supplies a model based estimate of the heat flux to an object which is coupled with a radiative fire environment. This implementation of CAFE provides an appropriate tool for analysts and designers performing scoping studies assessing the survivability of hazardous material shipping containers exposed to large pool fires.

The implementation of the CAFE model as a boundary condition option has been verified by comparing a P/THERMAL solution using this boundary condition to a finite difference solution of a simplified problem. The agreement between the results of these separate solutions verify the correct implementation of the CAFE model.

Acknowledgements

This work was performed by Sandia National Laboratories under Contract DE-AC04-94AL85000 to the U.S. Department of Energy

References

1. Nicolette, V.F., and Larson, D.W., "The Influence of Large, Cold Objects on Engulfing Fire Environments," *Heat and Mass Transfer in Fires*, **141** pp. 63-70, 1990
2. Mansfield, J. A., and Linley, L.J. "Measurement and Statistical Analysis of Flame Temperatures from Large Fuel Spill Fires," NWC TP 7061, Naval Air Weapons Center, China Lake.
3. P/THERMAL *Release 2.5 Notes*; PDA Engineering, PATRAN Division, 2975 Redhill Avenue, Costa Mesa, California 92626; p7.2,
4. Gritz, L.A., Nicolette, V.F., "Coupled Thermal Response of Objects and Participating Media in Fires and Large Combustion Systems", *Heat Transfer in Fire and Combustion Systems*. HTE Vol. 250, ASME 1993, (To appear in the Journal of Numerical Heat Transfer.)