

APPENDIX D

Linear Static Analysis of a Simply-Supported Stiffened Plate (SI)

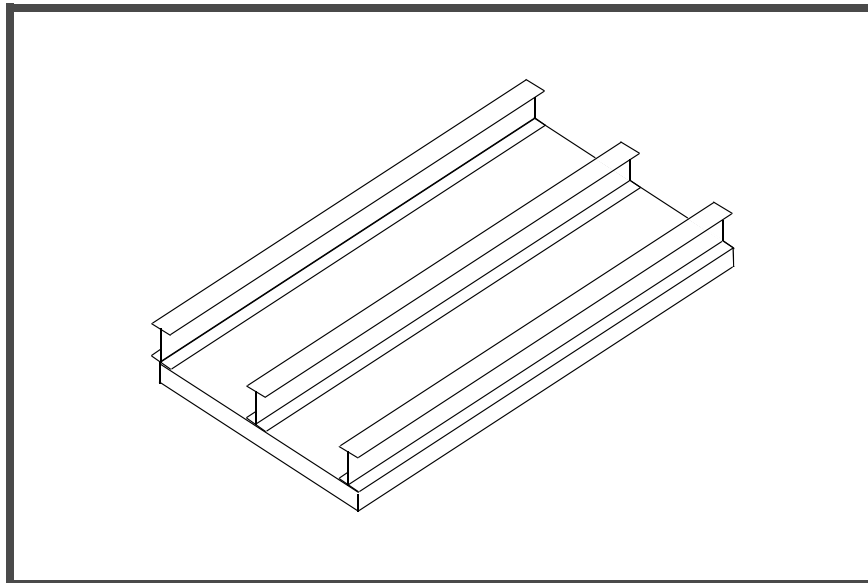

Objectives:

- Create a MSC.Nastran analysis model comprised of CQUAD4 & CBAR elements.
- Prepare a MSC.Nastran input file for a Linear Static analysis.
- Visualize analysis results.

Model Description:

Below is a finite element representation of the stiffened plate shown on page D-1. The plate is 2.54 mm thick; therefore thin-shell theory applies. I-beam stiffeners are mounted as shown. The structure has pin supports on its four corners and a uniform pressure of 3447 Pa is applied to the surface of the plate (See Figure D.3). Table 2.1 contains all the necessary values to define the material and property of the stiffened plate.

HINT: Because the centroidal axes of the stiffeners do not coincide with the mid-plane of the plate, you will need to account for this when you define the element properties for the stiffeners.

Figure D.1 - Model Schematics

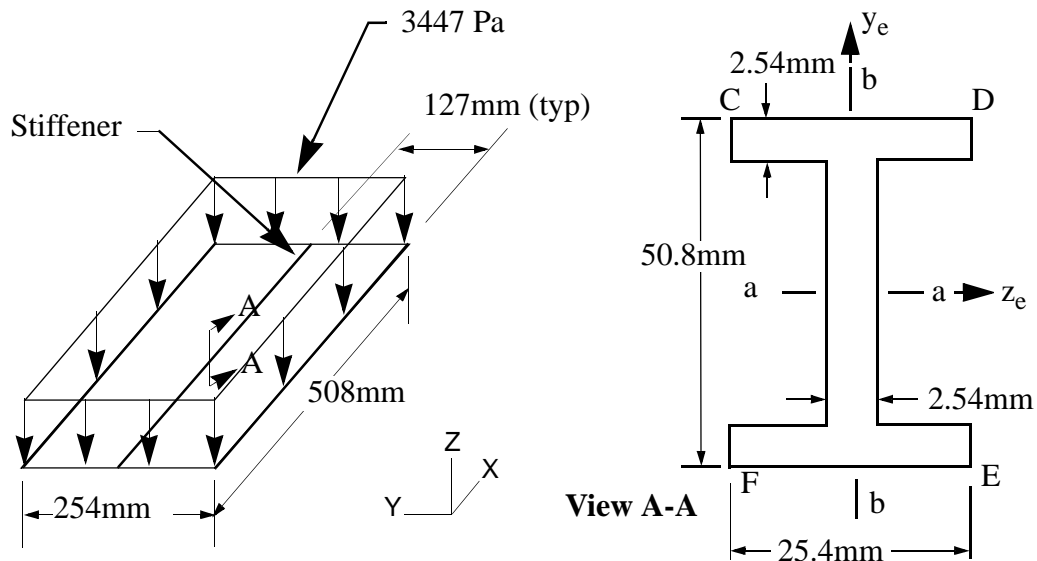

Table D.1 - Model Properties - Aluminum

Elastic Modulus:	71.0 GPa
Poisson Ratio	0.30
Density:	2796 kg/m³
Plate Thickness:	2.54 mm
Bar Cross-Sectional Area:	245.2 mm²
I_{aa}:	95,442 mm⁴
I_{bb}:	6,993 mm⁴
J:	541 mm⁴

Suggested Exercise Steps:

- Create a wire frame to use when mesh the plate and the stiffeners.
- Generate a finite element representation of the stiffened plate using nodes (GRID), element connectivities, (CBAR) and CQUAD4 element. Size mesh to match Figure D.2. Actual node numbers and element numbers may vary
- Define material (MAT1) and element properties (PSHELL & PBAR).
- Verify XY-orientation and offset vectors for the bar elements when defining PBAR properties.
- Define simply-supported boundary constraints (SPC1) and apply a uniform pressure load to the plate (PLOAD4).
- Prepare the model for a Linear Static analysis (SOL 101).
- Generate and submit input file for MSC.Nastran.
- Review the results.

Figure D.2 - Grid Coordinates and Element Connectivities

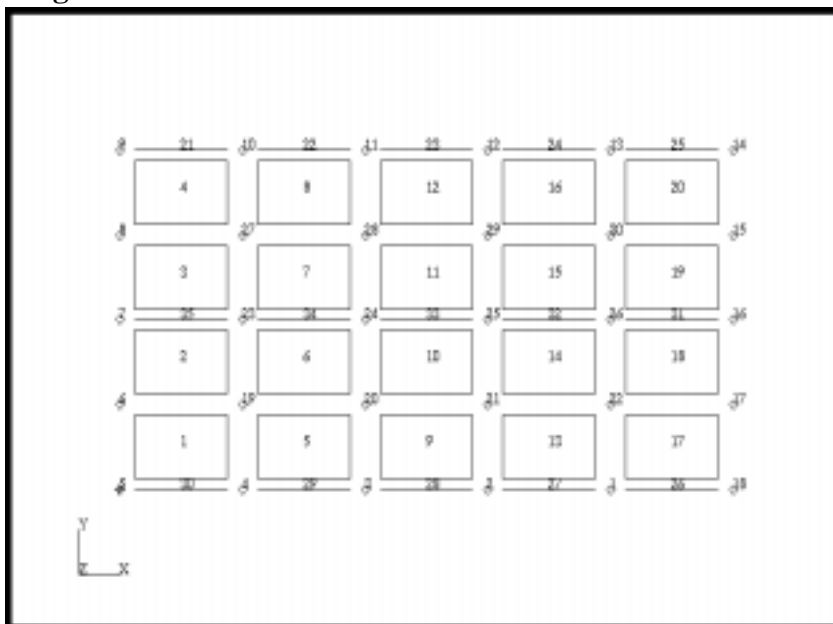
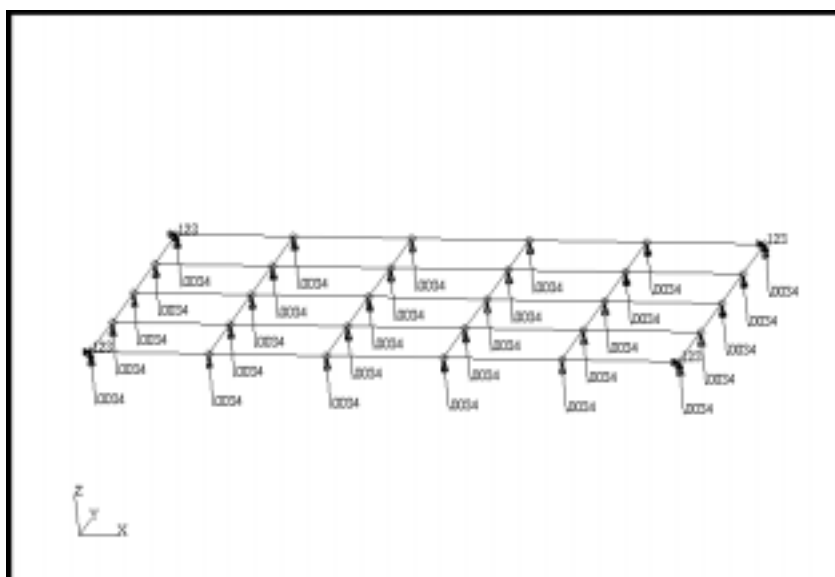

Figure D.3 - Loads and Boundary Conditions



Generating an Input File for MSC.Nastran Users:

1. MSC.Nastran users can generate an input file using the data from pages D-3 (general model description) and D-5 (NASTRAN model element IDs). The result should be similar to the output below (**ex02plate.dat**):

```
ID EXERCISE,CATIAFEM
SOL 101
CEND
$.
$-----
$.
$. CASE CONTROL DECK
$.

TITLE = EXERCISE 2 SIMPLY SUPPORTED STIFFENED PLATE
DISPL = ALL
ELSTRESS= ALL
MPC = 1
$.
SUBCASE = 1
$ CATIA RESTRAINT SET NAME :
$ PIN JOINTS
  SPC = 1
$ CATIA LOAD SET NAME :
$ PRESSURE LOAD
  LOAD = 1
$.
$-----
$.
$. BULK DATA CARDS
$.
$.
BEGIN BULK
PARAM POST 1
PARAM AUTOSPC YES
$.
$-----
$.
$. RESTRAINTS
$.
$ NASTRAN ID = 1 / RESTRAINT SET NAME :
$ PIN JOINTS
SPC1 1 123 5 9 14 18
$.
$-----
$.
$. LOADS
$.
$ NASTRAN ID = 1 / LOAD SET NAME :
$ PRESSURE LOAD
PLOAD4 1 1 -.003447
PLOAD4 1 2 -.003447
PLOAD4 1 3 -.003447
PLOAD4 1 4 -.003447
PLOAD4 1 5 -.003447
PLOAD4 1 6 -.003447
PLOAD4 1 7 -.003447
PLOAD4 1 8 -.003447
PLOAD4 1 9 -.003447
PLOAD4 1 10 -.003447
PLOAD4 1 11 -.003447
PLOAD4 1 12 -.003447
PLOAD4 1 13 -.003447
PLOAD4 1 14 -.003447
PLOAD4 1 15 -.003447
PLOAD4 1 16 -.003447
PLOAD4 1 17 -.003447
PLOAD4 1 18 -.003447
PLOAD4 1 19 -.003447
PLOAD4 1 20 -.003447
$.
$-----
$.
$. MATERIALS
```

CBAR	27	2	1	2	0.	0.	1.		7
+	7		0.	0.	26.67	0.	0.	26.67	
CBAR	28	2	2	3	0.	0.	1.		8
+	8		0.	0.	26.67	0.	0.	26.67	
CBAR	29	2	3	4	0.	0.	1.		9
+	9		0.	0.	26.67	0.	0.	26.67	
CBAR	30	2	4	5	0.	0.	1.		10
+	10		0.	0.	26.67	0.	0.	26.67	
CBAR	31	2	16	26	0.	0.	1.		11
+	11		0.	0.	26.67	0.	0.	26.67	
CBAR	32	2	26	25	0.	0.	1.		12
+	12		0.	0.	26.67	0.	0.	26.67	
CBAR	33	2	25	24	0.	0.	1.		13
+	13		0.	0.	26.67	0.	0.	26.67	
CBAR	34	2	24	23	0.	0.	1.		14
+	14		0.	0.	26.67	0.	0.	26.67	
CBAR	35	2	23	7	0.	0.	1.		15
+	15		0.	0.	26.67	0.	0.	26.67	
\$. .									

\$. .									
\$. .									
\$. .									
\$. .									
PROPERTYIES									
\$. .									
PSHELL	1	1	2.54	1	1.	1	.83333		
PBAR	2	1	245.2	95442.	6993.	541.			16
+	1625.4	-12.7	25.4	12.7	-25.4	-12.7	-25.4	12.7	
\$. .									
ENDDATA									

Submitting the Input File for Analysis:

2. When the run is completed, edit the **ex02plate.f06** file and search for the word **FATAL**. If no matches exist, search for the word **WARNING**. Determine whether existing **WARNING** messages indicate modeling errors.

2a. While still editing **ex02plate.f06**, search for the word:

D I S P L A C E (spaces are necessary).

What are the components of the displacement vector for GRID 25 (translation only)?

disp X = _____
 disp Y = _____
 disp Z = _____

Search for the word:

S T R E S S (spaces are necessary)

What is the axial stress for CBAR 33?

axial stress = _____

Search for the word:

Q U A D (spaces are necessary)

What are the centroidal Von Mises stresses for CQUAD4 11?

-(thk/2): stress = _____
 +(thk/2): stress = _____

Comparison of Results:

3. Compare the results obtained in the **.f06** file with the results on the following page.

D I S P L A C E M E N T V E C T O R

POINT ID.	TYPE	T1	T2	T3	R1	R2	R3
22	G	-1.976656E-04	-8.198572E-05	1.198532E+00	1.454896E-02	7.856132E-04	0.0
23	G	1.420448E-04	-2.032879E-18	1.684084E+00	5.767956E-17	2.532538E-06	-1.033706E-18
24	G	3.750603E-05	4.770490E-18	1.683930E+00	6.071532E-17	7.128691E-07	1.517883E-18
25	G	-3.750603E-05	-4.702727E-18	1.683930E+00	4.800305E-17	-7.128691E-07	3.113693E-18
26	G	-1.420448E-04	-1.151965E-18	1.684084E+00	4.022390E-17	-2.532538E-06	2.098515E-18
27	G	1.976656E-04	8.198572E-05	1.198532E+00	-1.454896E-02	-7.856132E-04	0.0
28	G	1.074019E-04	-9.067759E-05	1.203637E+00	-1.445164E-02	6.483336E-04	0.0

(C B A R)

ELEMENT ID.	S T R E S S E S I N B A R E L E M E N T S				A X I A L S T R E S S		S A - M I N S B - M I N		M . S . - T M . S . - C	
	SA1 SB1	SA2 SB2	SA3 SB3	SA4 SB4	SA SB	SA SB	SA-MIN SB-MIN	SA-MIN SB-MIN	M.S.-T M.S.-C	
31	-7.325063E-02	-7.325063E-02	7.325063E-02	7.325063E-02	-6.349257E-02	9.758055E-03	-1.367432E-01			
32	-5.995434E-02	-5.995434E-02	5.995434E-02	5.995434E-02	-1.069677E-01	-3.538236E-03	-1.234469E-01			
33	-2.096744E-02	-2.096744E-02	2.096744E-02	2.096744E-02	-7.899203E-02	-5.368518E-02	-1.042989E-01			
34	-2.530685E-02	-2.530685E-02	2.530685E-02	2.530685E-02	-1.069677E-01	-8.600031E-02	-1.279352E-01			
35	-4.363080E-02	-4.363080E-02	4.363080E-02	4.363080E-02	-6.349257E-02	-3.538240E-03	-1.234469E-01			

S T R E S S E S I N Q U A D R I L A T E R A L E L E M E N T S (Q U A D 4)

ELEMENT ID.	FIBRE DISTANCE	S T R E S S E S I N E L E M E N T S (Q U A D 4)			P R I N C I P A L S T R E S S E S (Z E R O S H E A R)		V O N M I S E S	
		NORMAL-X	NORMAL-Y	SHEAR-XY	MAJOR	MINOR	MAJOR	MINOR
8	-1.270000E+00	9.923518E+00	3.447110E+00	1.216517E-01	1.0757	9.925802E+00	3.444826E+00	8.729016E+00
9	1.270000E+00	-9.943161E+00	-3.847236E+00	1.903856E-01	88.2129	-3.841296E+00	-9.949101E+00	8.690382E+00
10	-1.270000E+00	9.470063E+00	1.950759E+00	-7.520868E-14	0.0000	9.470063E+00	1.950759E+00	8.661047E+00
	1.270000E+00	-9.648311E+00	-2.713698E+00	6.769064E-14	90.0000	-2.713698E+00	-9.648311E+00	8.618089E+00
	-1.270000E+00	2.221622E+01	5.987573E+00	-5.883420E-14	0.0000	2.221622E+01	5.987573E+00	1.990955E+01
	1.270000E+00	-2.250582E+01	-6.276981E+00	-6.795719E-15	-90.0000	-6.276981E+00	-2.250582E+01	2.011576E+01