

Exercise 2

Geometry Model of a Space Satellite

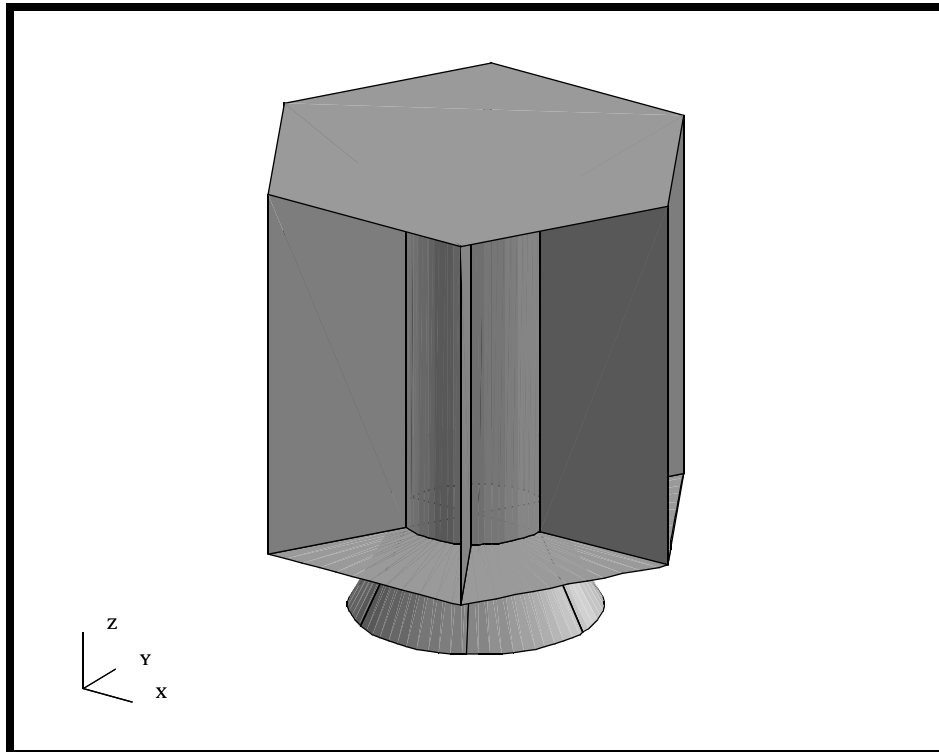

Objectives:

- Create geometry for a Satellite.
- Create group for each portion of the Satellite.
- Change the graphics display.



Model Description:

Shown below is a drawing of the Satellite you will be building as well as the suggested exercise steps. The concept for the Satellite series of exercises was presented to MSC by Carl Woo of TRW Space and Communications, Redondo Beach. The Satellite is made of many thin structures which will be idealized as plate elements. Some of the secondary structures, such as the propulsion module, navigational platform and science experiments, will be idealized as lumped masses with the supporting structure. Thus, for modeling purposes, this model is composed primarily of surfaces. The model will be initially broken up into 6 groups, each representing a separate piece of the structure. These groups include:

- Lower Platform
- Upper Platform
- Adapter Cone
- Shear Panels
- Central Cylinder
- All Geometry

In this exercise, you will create the geometry for a Satellite by defining MSC.Patran points, curves, surfaces, and two user defined coordinate systems; one coordinate system locates the vehicle for On-Orbit and the other locates the vehicle for Launch. Throughout this exercise, you will become familiar with the use of the MSC.Patran *Geometry* and *Group* menus. You will also be introduced to *Viewing* methods and shown how to change the model's render style.

In later exercises, we will be meshing the geometry with Quad and Bar elements and assigning appropriate properties and materials. We will use MSC.Patran to verify the model mass properties and elements to ensure model integrity. We will be submitting and analyzing the model using MSC.Nastran. The final step will use MSC.Patran to review the results. Therefore, do not delete the model database when you are done with this exercise because we will be using it again.

Figure 1.1. Geometry specifications for the satellite.

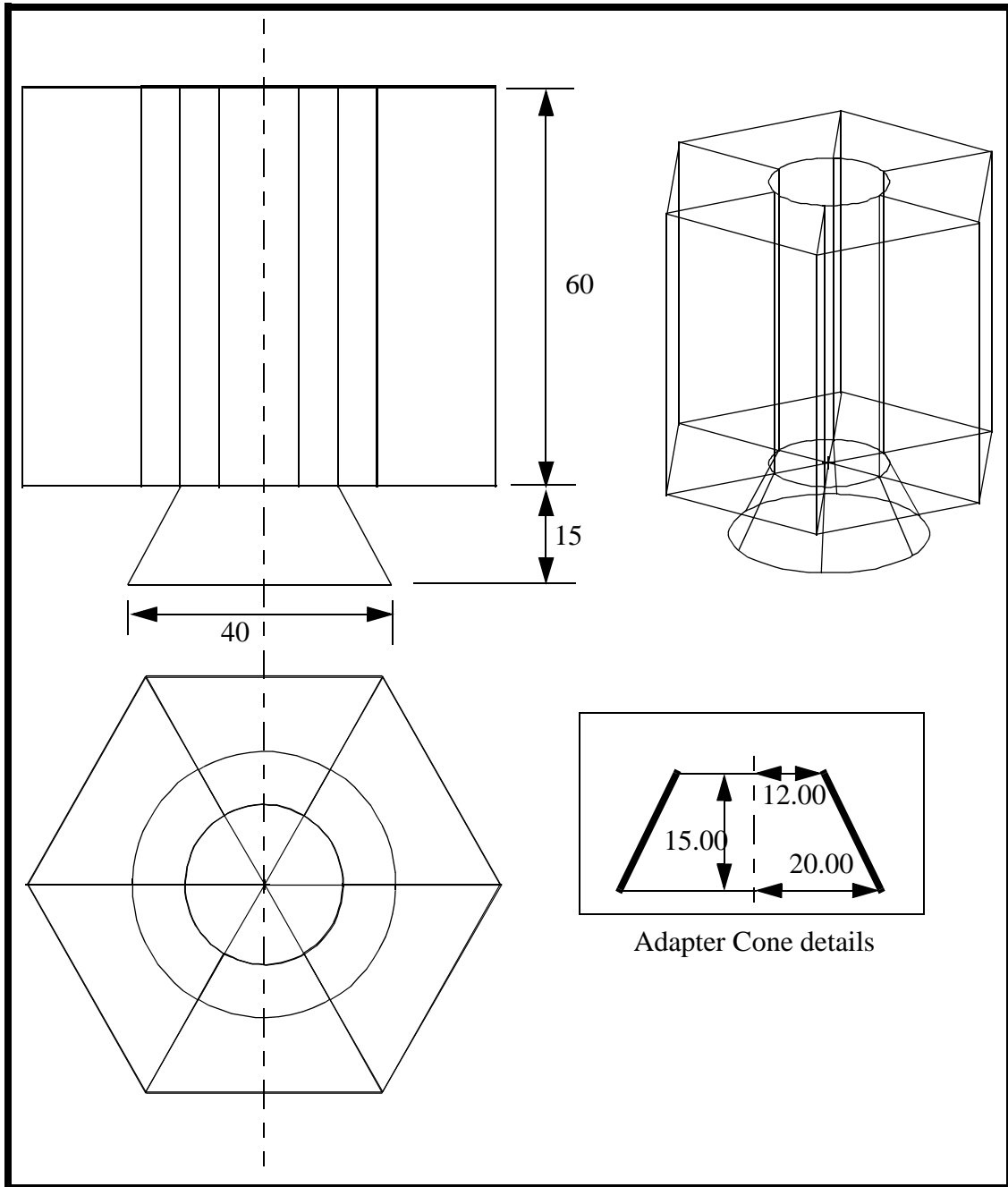

Suggested Exercise Steps:

- Create a new database and name it as **satellite.db**.
- Create a group for the Lower Platform.
- Build 1/6 surfaces for the Lower Platform.
- Complete the Lower Platform geometry by rotating 1/6 surface with an angle of 60 degrees and a repeat factor of 5.
- Create a group for the Upper Platform.
- Transform the outside edges of the Lower Platform 60 units in +Z direction.
- Create a trimmed surface to represent the Upper Platform using the transformed curves.
- Create a group for the Central Cylinder.
- Build the Central Cylinder surfaces by extruding the inner surface edges of the Lower Platform. The extrude distance is 60 units in +Z direction.
- Create a group for the Shear Panels.
- Build the Shear Panels surfaces by extruding the radial curves of the Lower Platform. The extrude distance is 60 units in +Z direction.
- Create a group for the Adapter Cone.
- Create 1/6 of geometry for the Adapter Cone by defining an axisymmetric slice and revolving it by 60 degrees.
- Complete the remainder of the Adapter Cone geometry by revolving the created surface with an angle of 60 degrees and a repeat factor of 5.
- Create a group that contains all the geometry.
- Write out an IGES file of the geometry.
- Close and Exit MSC.Patran.

Exercise Procedure:

*Note: In most MSC.Patran forms, the default setting for the **Auto Execute** button is on; thus, you do not need to press **Apply**.*

Open a New Database

1. Create a new database and name it as **satellite.db**.

File/New...

New Database Name

satellite

OK

New Model Preferences

Tolerance

◆ **Default**

OK

2. The first component you shall build is the Lower Platform. Let's create a group for it.

There are many ways of grouping entities inside MSC.Patran. In this exercise, you will create groups prior to building any entities. The newly created group will be set current. The current group is the group that collects new entities and there can be only one current group at a time. This way, any new entities will automatically be placed into the newly created current group. We will start with the Lower Platform.

Group/Create...

New Group Name

Lower Platform

Make Current

Unpost All Other Groups

Apply

Cancel

3. Before we get started, we will change the view using the Toolbar to an Isometric view



Isometric View 3

Reset the View

4. Create the geometry for Lower Platform. We will start by creating two curves that represent a radial slice.

◆ **Geometry**

<i>Action:</i>	Create
<i>Object:</i>	Curve
<i>Method:</i>	XYZ
<i>Vector Coordinates List</i>	<12, 0, 0>
<i>Origin Coordinates List</i>	[0, 0, 0]

Apply

This automatically creates the curve with two end points. To see the newly created points more clearly, simply increase the point size using the Toolbar icon.



Point Size

Also, turn on the Show Labels using the following toolbar icon.



Show Labels

**Create
Curves
Using XYZ
Method**

Figure 1.2. The first radial line for the Lower Platform.

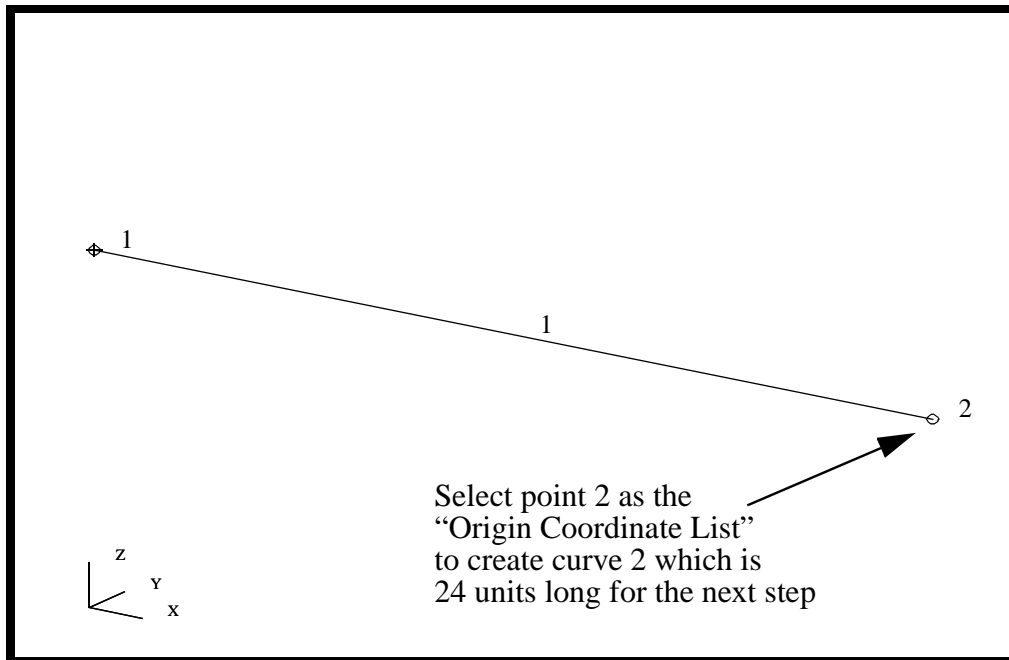

We will create the second portion of slice by extending the curve, from point 2, for 24 units.

<i>Action:</i>	Create
<i>Object:</i>	Curve
<i>Method:</i>	XYZ
<i>Vector Coordinates List</i>	<24, 0, 0>
<i>Origin Coordinates List</i>	Point 2 

Note: This point can be selected using your mouse as shown in the Figure 1.2

In most MSC.Patran forms the default setting for the **Auto Execute** button is On. If the **Auto Execute** button is on, the curve will be automatically created. If the **Auto Execute** switch is off and the point has been selected, hit:

Apply

Figure 1.3. The completed radial slice of the Lower Platform.

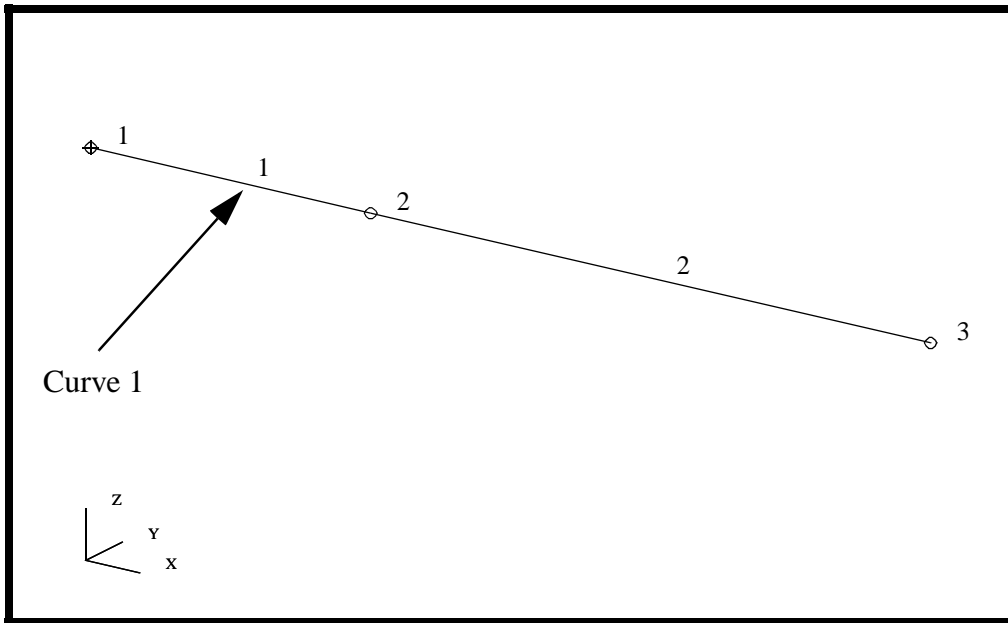

5. Create the first 1/6 surface of the Lower Platform by revolving Curve 1 with an angle of 60 degrees.

Action:

Create

Object:

Surface

Method:

Revolve

Total Angle

60

Curve List

Curve 1

Note: This curve can be selected using your mouse, see Fig. 1.3

Create 1/6 of the Lower Platform

Again, if the **Auto Execute** button is on, you do not need to press **Apply**.

Curves 1 & 2 and Surface 1 can now be seen in the Viewport.

Figure 1.4. The first surface of the Lower Platform.

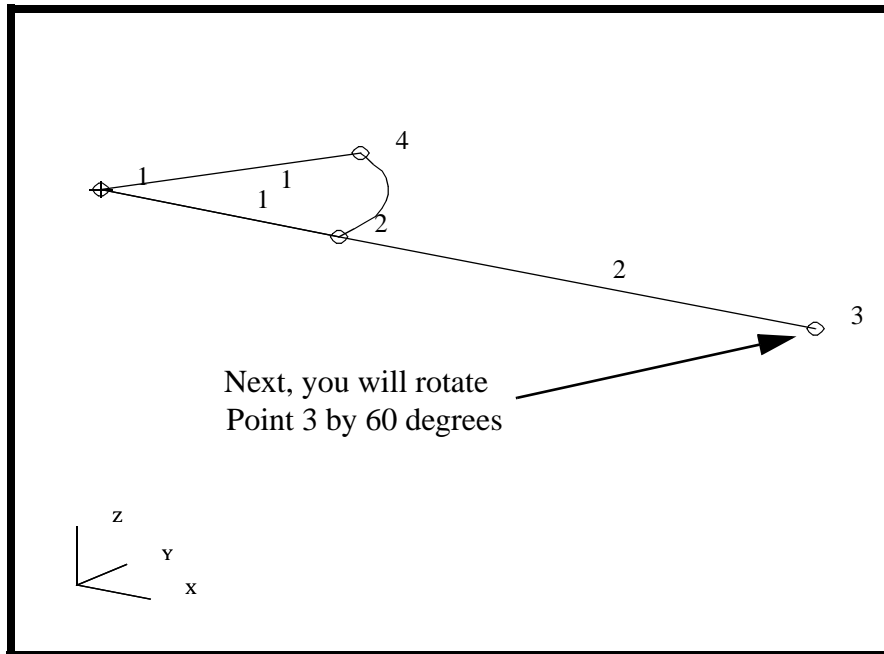

You will now use Point Transform to create the vertex for the outer edge of the satellite by radially rotating Point 3 by 60 degrees.

This process was rather simple, since the desired coordinate system and axis were already defined by the defaults for the form.

Transform a Point by Rotation



<i>Action:</i>	Transform
<i>Object:</i>	Point
<i>Method:</i>	Rotate
<i>Rotation Angle</i>	60
<i>Repeat Count</i>	1
<i>Point List</i>	Point 3  (see Figure 1.4)

Again, if the **Auto Execute** button is on, you do not need to press **Apply**.

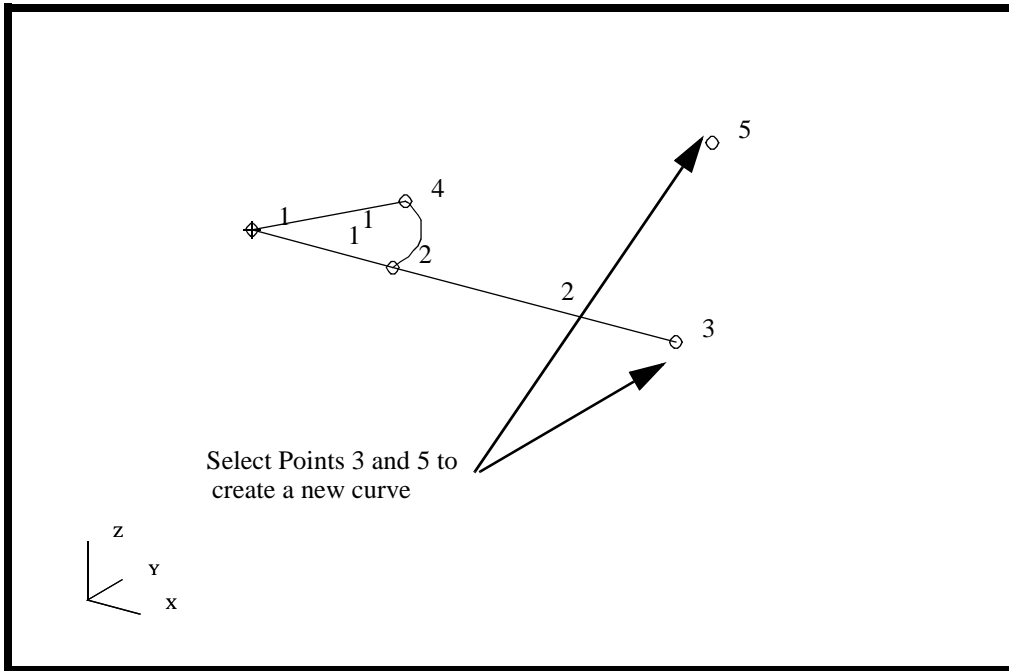
Figure 1.5. Selected points to create the outer edge of the Lower Platform.



Next, we will connect Point 3 and 5 to create an outer edge curve for the 1/6 Lower Platform.



<i>Action:</i>	Create
<i>Object:</i>	Curve
<i>Method:</i>	Point
<i>Option:</i>	2 Point
<i>Starting Point List</i>	Point 3 
<i>Ending Point List</i>	Point 5 

Your model should now look like the figure below.

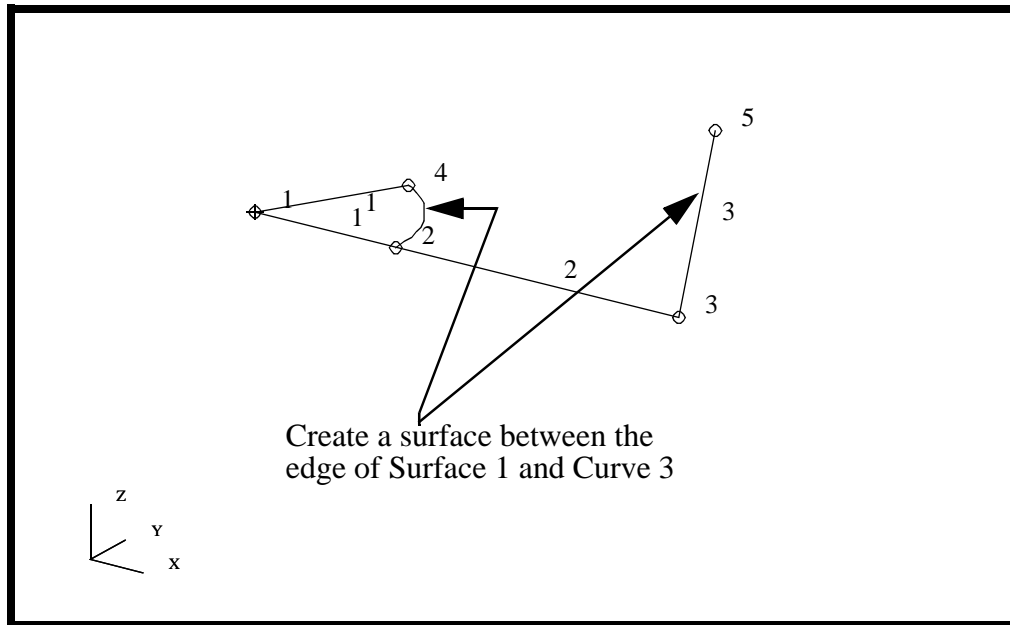
Figure 1.6. Selected edges to make the remainder of the 1/6 slice of the Lower Platform.



Finally, we will create the last surface to complete the 1/6 segment of the Lower Platform. The curve will be constructed by using the newly created curve and the edge of Surface 1.

<i>Action:</i>	Create
<i>Object:</i>	Surface
<i>Method:</i>	Curve
<i>Option:</i>	2 Curve
<i>Starting Curve List</i>	See Fig. 1.6 
<i>Ending Curve List</i>	See Fig. 1.6 

To better visualize the surfaces, you can turn off the labels, reset the point size, and turn on the smooth shaded render style from the toolbar.



Hide Labels



Point Size



Smooth Shaded

Your model should now look like the figure below.

Figure 1.7. 1/6 slice of the Lower Platform.

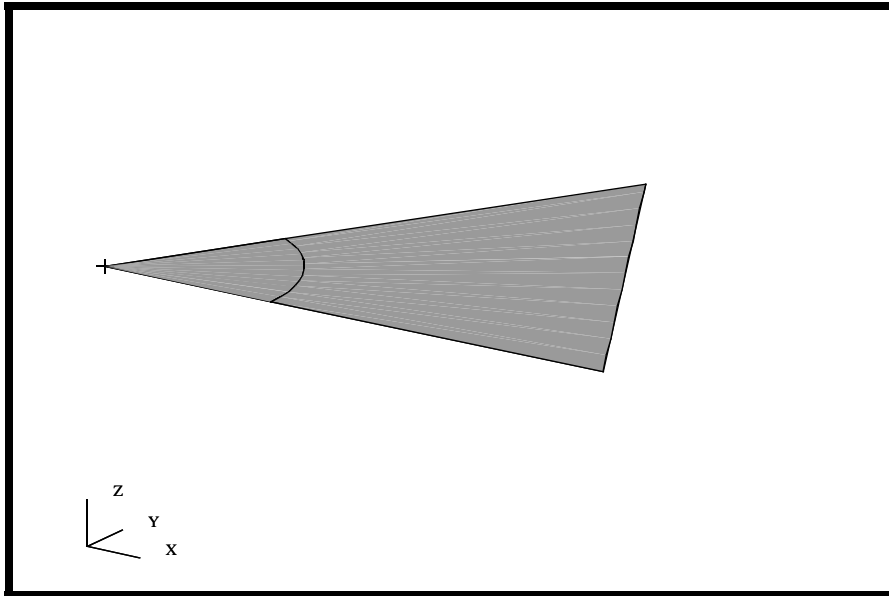

- We will create the remaining surfaces for the Lower Platform. These surfaces will be created by rotating the slice just created with an angle of 60 degrees and five times.

<i>Action:</i>	Transform
<i>Object:</i>	Surface
<i>Method:</i>	Rotate
<i>Rotation Angle</i>	60
<i>Repeat Count</i>	5
<i>Surface List</i>	Select all posted surfaces (see Figure 1.8) 

**Create the
Remainder
of the Lower
Platform**

Note: You can drag select both surfaces using a rubberband pick as shown below.

Figure 1.8. Using the rubberband pick method to select all the surfaces.

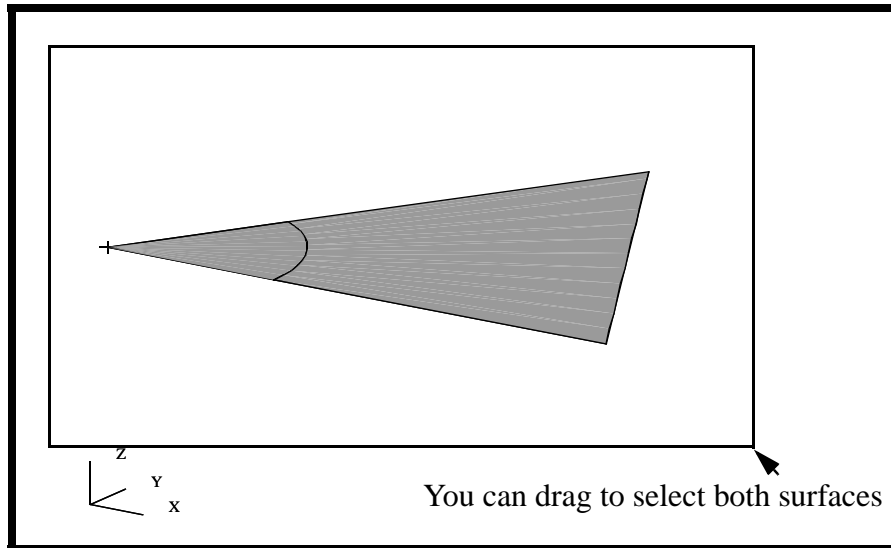

You have now completed the creation of all the surfaces for the Lower Platform. We will use the surfaces from the Lower Platform to create the Upper Platform in the next step. Your model should now look like the figure below.

Figure 1.9. Lower Platform geometry in shaded image.

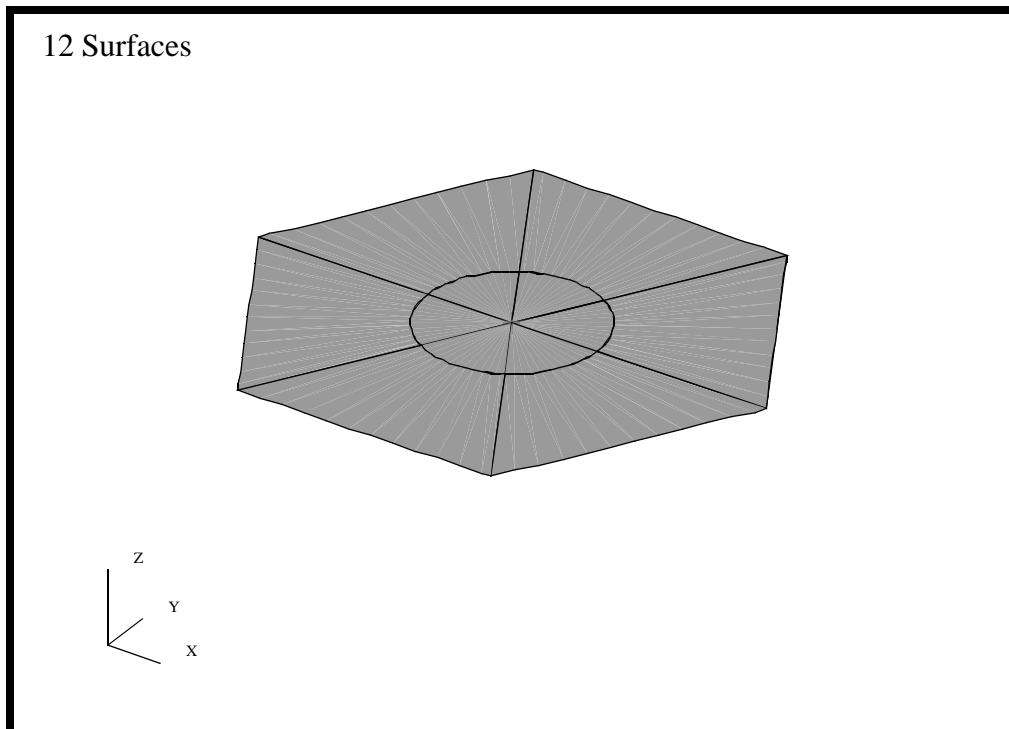

7. In this step, we will create a group for the Upper Platform.

Again, we will create a group prior to the creation of any new geometry. This way, any new entities will automatically be placed into the current group.

Create a Group for the Upper Platform

Group/Create...

New Group Name

Upper Platform

- Make Current**
 Unpost All Other Groups

Apply

Cancel

8. As in any exercise, there are many different ways to approach a problem. In the next step, you will create the geometry for the Upper Platform, which is located 60 units above the Lower Platform. The obvious method of creating the identical geometry is to simply transform the lower geometry 60 units up. This is probably the quickest method. However, for this exercise, we will use a different method to create the geometry to illustrate other capabilities/techniques.

Create Geometry for the Upper Platform

Let's first change the render style back to Wireframe using the Toolbar icon shown below.



Wireframe

Figure 1.10. Edges of the Lower Platform which will be Transformed to make the upper surface.

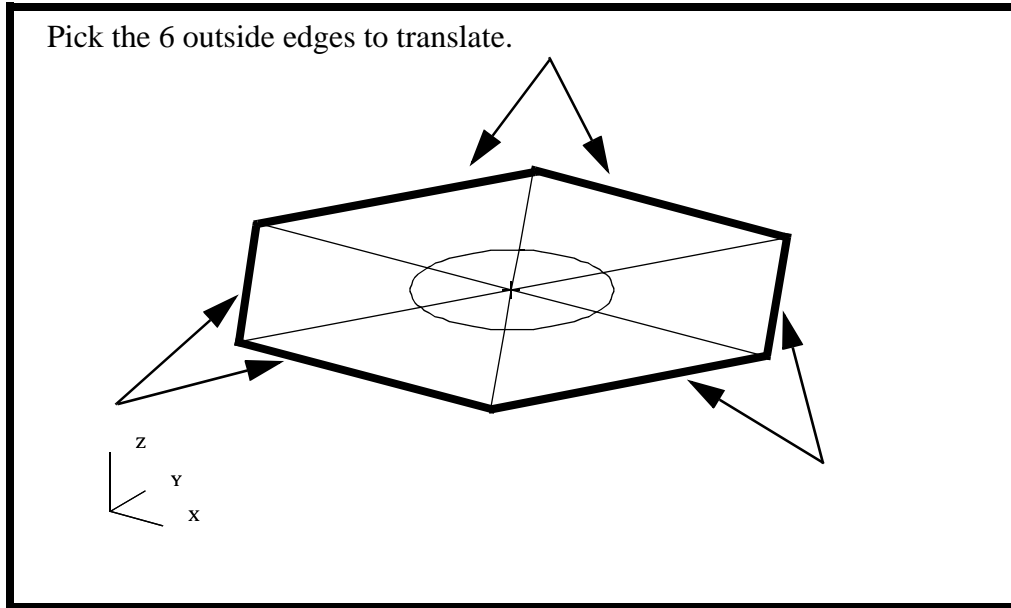

We will create the Upper Platform surface by defining a Planar Trimmed Surface that is constructed from 6 bounding curves. We will first create the 6 bounding curves by transforming the outside edges of the Lower Platform 60 units in +Z direction.

<i>Action:</i>	<input type="text" value="Transform"/>
<i>Object:</i>	<input type="text" value="Curve"/>
<i>Method:</i>	<input type="text" value="Translate"/>
<i>Translation Vector</i>	<input type="text" value="<0, 0, 60>"/>
<i>Repeat Count</i>	<input type="text" value="1"/>
<i>Curve List</i>	<input type="text" value="See Figure 1.10"/>

As long as the **Auto Execute** is on, you can consecutively pick the outside edges and they will be transformed automatically.

Now, we will use these curves to create a Planar Trimmed Surface.

<i>Action:</i>	<input type="text" value="Create"/>
<i>Object:</i>	<input type="text" value="Surface"/>
<i>Method:</i>	<input type="text" value="Trimmed"/>

Option:

Planar

Auto Chain...

Select a Start Curve

Choose any curve that makes up the outside edges of the Upper Platform

Do you wish to delete the original curves?

Yes

Cancel

Outer Loop List

Choose the newly created chained curve

Apply

Do you wish to delete the original curves?

YES

This will create a single trimmed surface that will represent the Upper Platform. You may note that the underlying geometry, the Shear Panels and Central Cylinder, are not congruent and normally the mesh will not align. We will take care of that in a subsequent step.

Your model should look like the figure below.

Figure 1.11. Upper platform surface (1) general trimmed surface. Lower platform surfaces (12) parametric surfaces

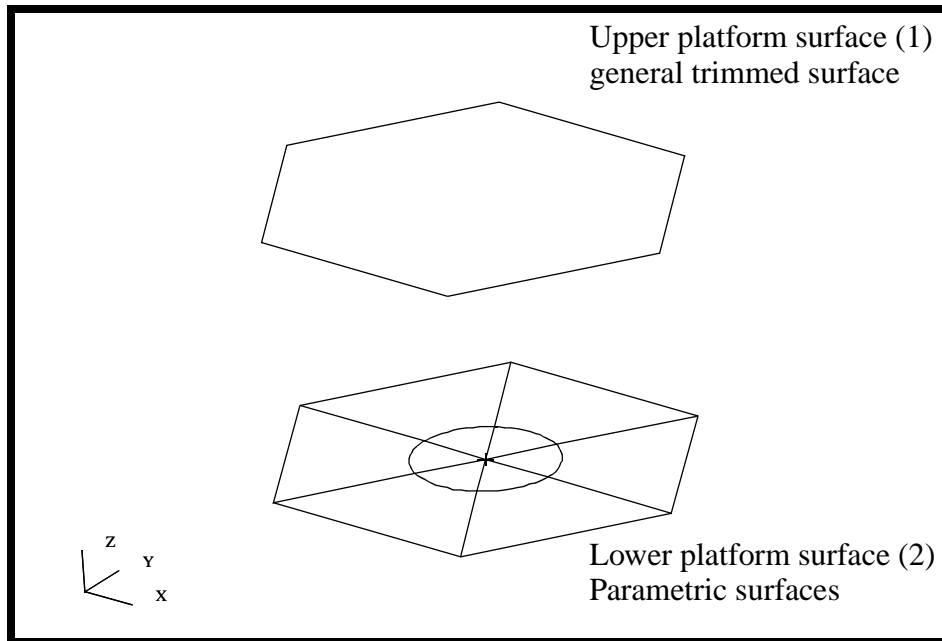

Transform a Point by Translation

- In this step, we will create a point at the center of the Upper Platform by transforming the center point from the Lower Platform.

Since we will be working with points, we can better visualize the points by selecting the Point size icon from the Toolbar.



Point size

The process of transforming the point is rather simple since the desired coordinate system and axis were already defined by the defaults of the form.

<i>Action:</i>	Transform
<i>Object:</i>	Point
<i>Method:</i>	Translate
<i>Translation Vector</i>	<0, 0, 60>
<i>Repeat Count</i>	1
<i>Point List</i>	See Figure 1.12 

Your model should look like the figure below.

Figure 1.12. Point on Lower Platform that will be translated.

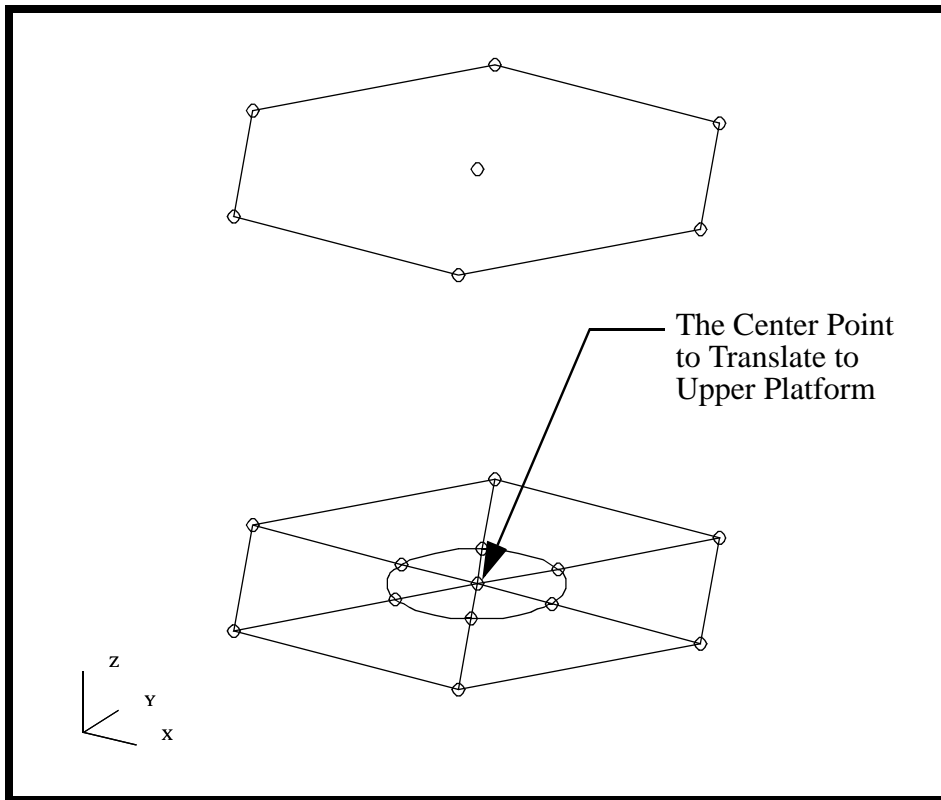

- In this step, we will create a group for the Central Cylinder.

We will be creating a group prior to building any new geometry. This way, any new entities will automatically be placed into the current group.

Create a Group for the Central Cylinder

Group/Create...

New Group Name

Central Cylinder

Make Current

Unpost All Other Groups

Apply

Cancel

Create the Geometry for the Central Cylinder

11. We will create the Central Cylinder surfaces by extruding the 1-D curve geometry.

We will create the Central Cylinder surfaces by extruding 6 circular edges of the Lower Platform. We will define the same Translation Vector as before, 60 units in the +Z direction.

<i>Action:</i>	Create
<i>Object:</i>	Surface
<i>Method:</i>	Extrude
<i>Translation Vector</i>	<0, 0, 60>
<i>Curve List</i>	See Figure 1.13 

Figure 1.13. The extruding curves for Central Cylinder.



As long as the **Auto Execute** is on, you can consecutively pick the inside edges and they will be extruded automatically.

Again, to better visualize the surfaces, turn on the Smooth shaded render style from the Toolbar icons.

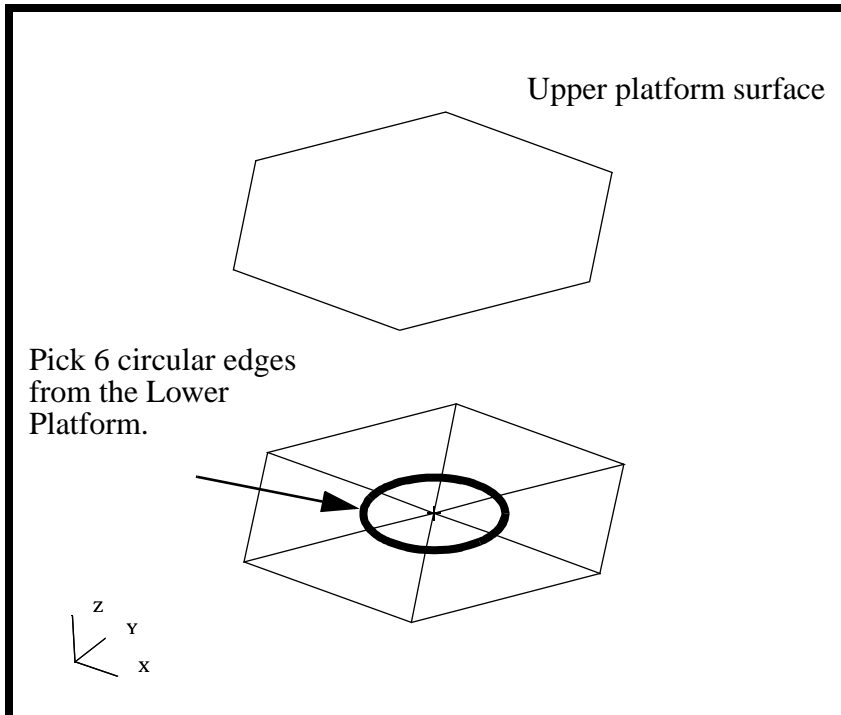

Figure 1.14. The completed Central Cylinder surfaces shown with the Upper and Lower Platforms.

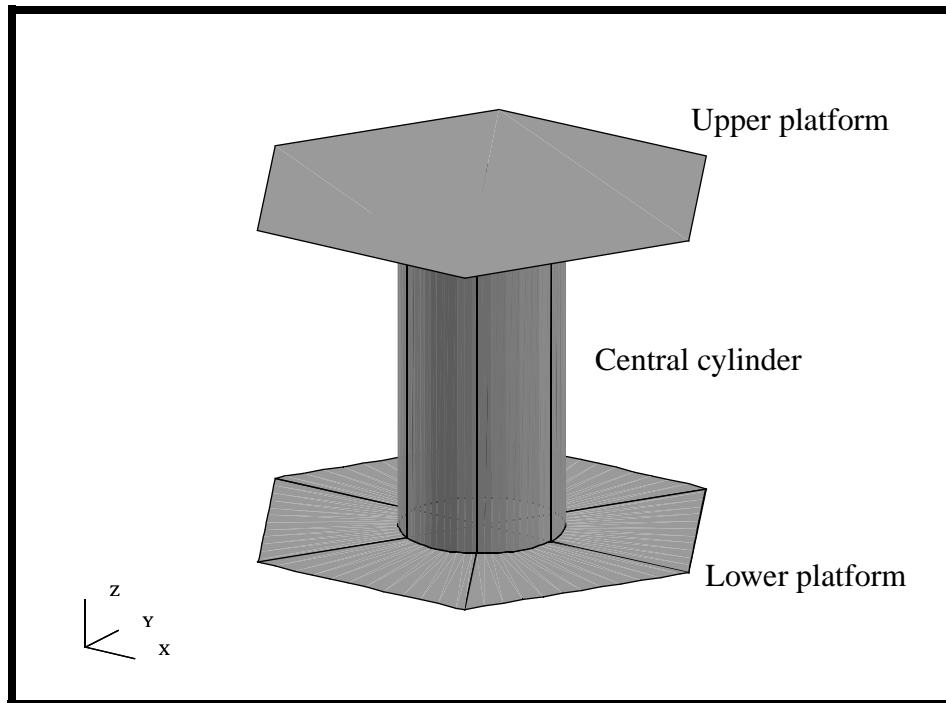

Let's change the render style back to Wireframe and shrink the Point size using the Toolbar icons shown below before we continue.



Wireframe



Point size

12. We will create a group for all the Shear Panels. This group will be set current so that any new geometry will be automatically added to this group.

Group/Create...

Create a Group for the Shear Panels

New Group Name

Shear Panels

- Make Current**
- Unpost All Other Groups**

Apply

Cancel

**Create the
Geometry
for the
Shear
Panels**

13. We will use 6 outer radial lines of the Lower Platform geometry to create the surfaces for the Shear Panels. We will define the same Translation Vector as before, 60 units in +Z direction.

Action:

Create

Object:

Surface

Method:

Extrude

Translation Vector

<0, 0, 60>

Curve List

See
Figure 1.15 

Figure 1.15. The extruding curves for Shear Panels.



Again, as long as the **Auto Execute** is on, you can consecutively pick the radial lines and they will be extruded automatically.

To better visualize the surfaces, turn on the Smooth shaded render style from the Toolbar icons.

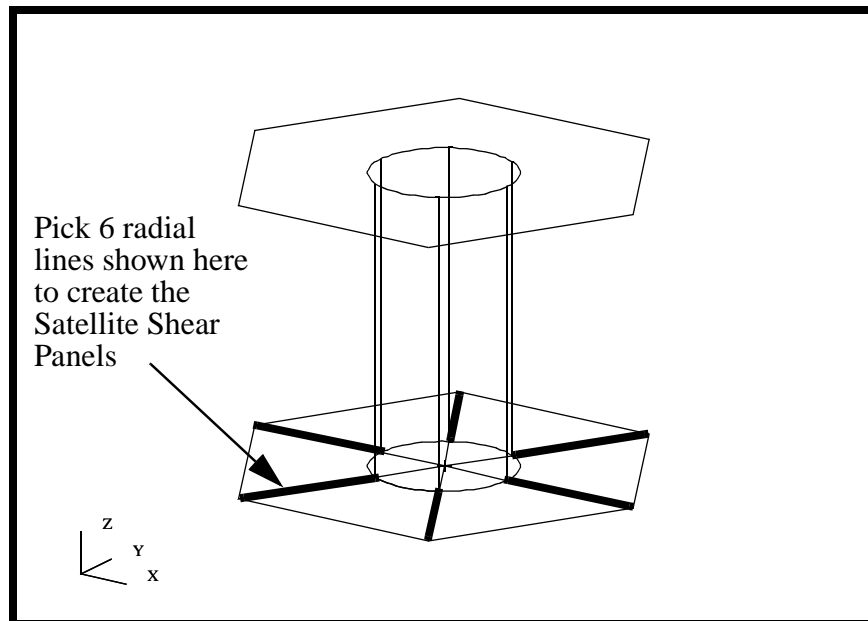

Smooth Shaded

Your model should be similar to the one below.

Figure 1.16. Shear Panels, Central Cylinder and Upper and Lower Platform.

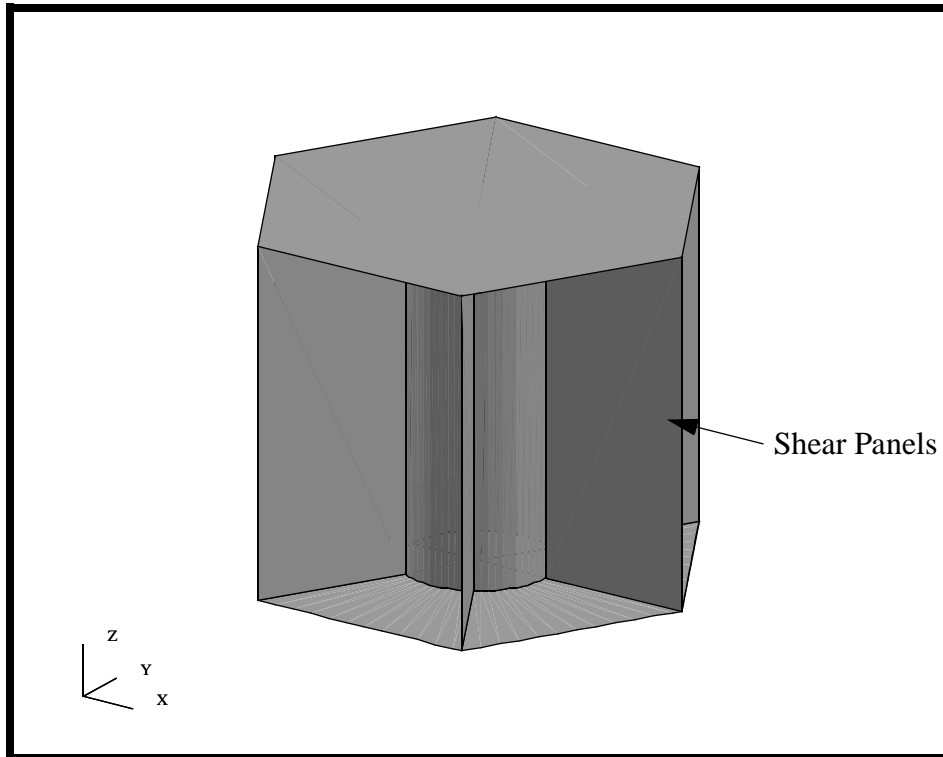

14. In this step, we will create a group for the Adapter Cone.

To reduce the amount of clutter on the screen, we will display only the Lower Platform.

Create a Group for the Adapter

Group/Post...

Select Groups to Post

Central Cylinder
Lower Platform
Shear Panels
Upper Platform
default_group

Apply

Prior to apply, the Lower Platform should be the only group highlighted. Once applied, the Lower Platform will be the only entities displayed in your graphics window.

While you are still in the **Group** form, change the *Action* from Post to Create so that any Adapter entities created will be automatically added.

Action:

Create

New Group Name

Adapter

Make Current

Unpost All Other Groups

Apply

Cancel

Create a 2-D Slice of the Adapter Cone

15. In this step, we will create the geometry for the Adapter Cone. We will first create a curve and then revolve this curve to create a surface.

Before we start the next step, let's change the view, render style, and the Point size using the Toolbar icons.



Front view



Wireframe



Point size

The geometry for the curve that defines an axisymmetric slice of the Adapter Cone is shown below. We will create this curve using a simple XYZ construct method.

Figure 1.17. An axisymmetric 2-D slice of the Adapter Cones's geometry.

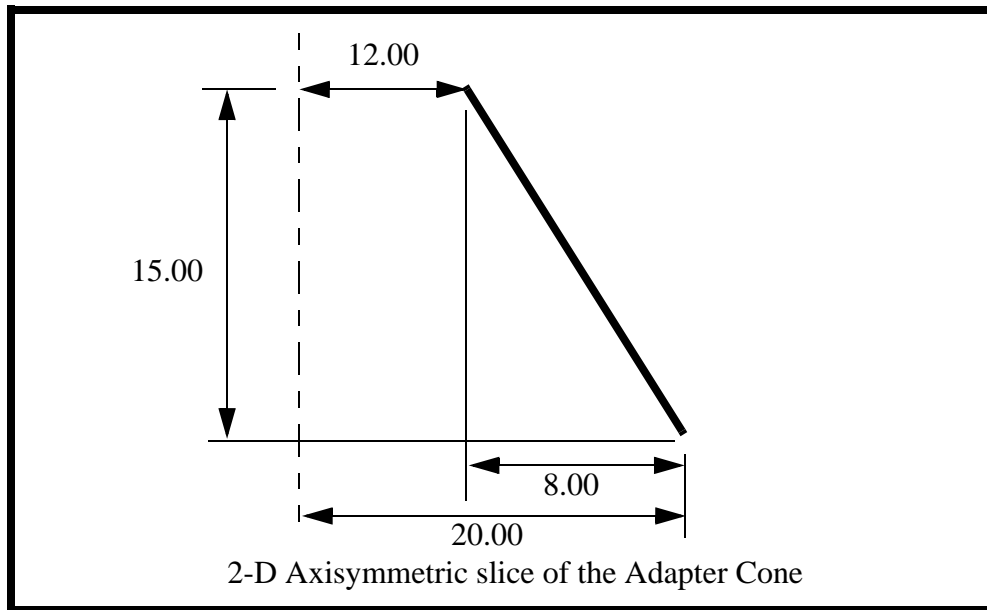

We will create this curve using a simple XYZ construct method.

Action:

Create

Object:

Curve

Method:

XYZ

Vector Coordinates List

<8, 0, -15>

Origin Coordinates List

See Figure
1.18

Figure 1.18. Selected point to create the Adapter curve.

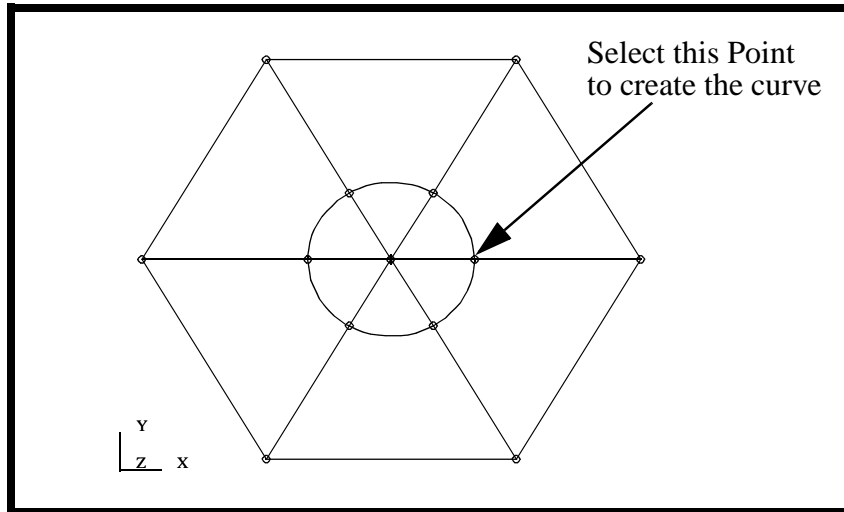

Change the view back to the Isometric view using the Toolbar icons.



Your model should look like the figure below.

Figure 1.19. Your Adapter curve should be similar to the one shown below.

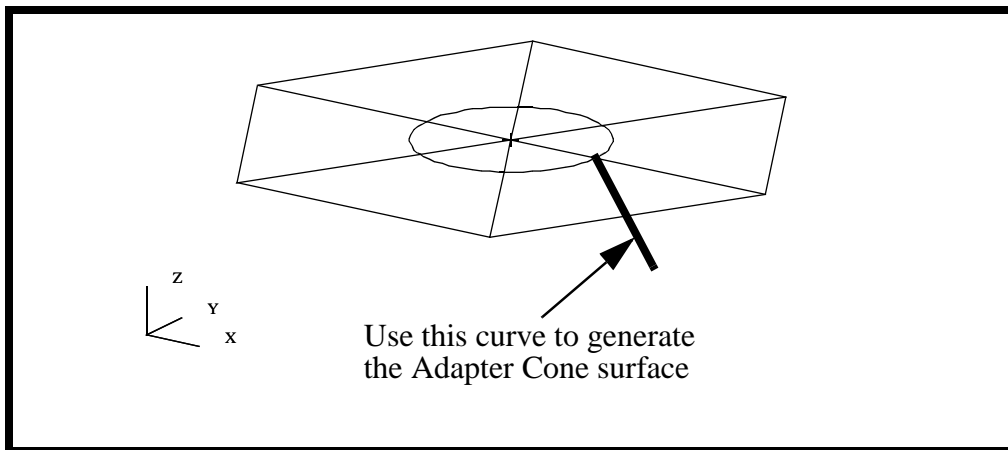

We shall revolve the newly created curve to create the Adapter Cone surface with an angle of 60 degrees.

Create 1/6 surface of the Adapter Cone

<i>Action:</i>	Create
<i>Object:</i>	Surface
<i>Method:</i>	Revolve
<i>Total Angle</i>	60.0
<i>Curve List</i>	See Figure 1.19 

Your model should look like the figure below.

Figure 1.20. 1/6 slice of the Adapter Cone shown with the Lower Platform.

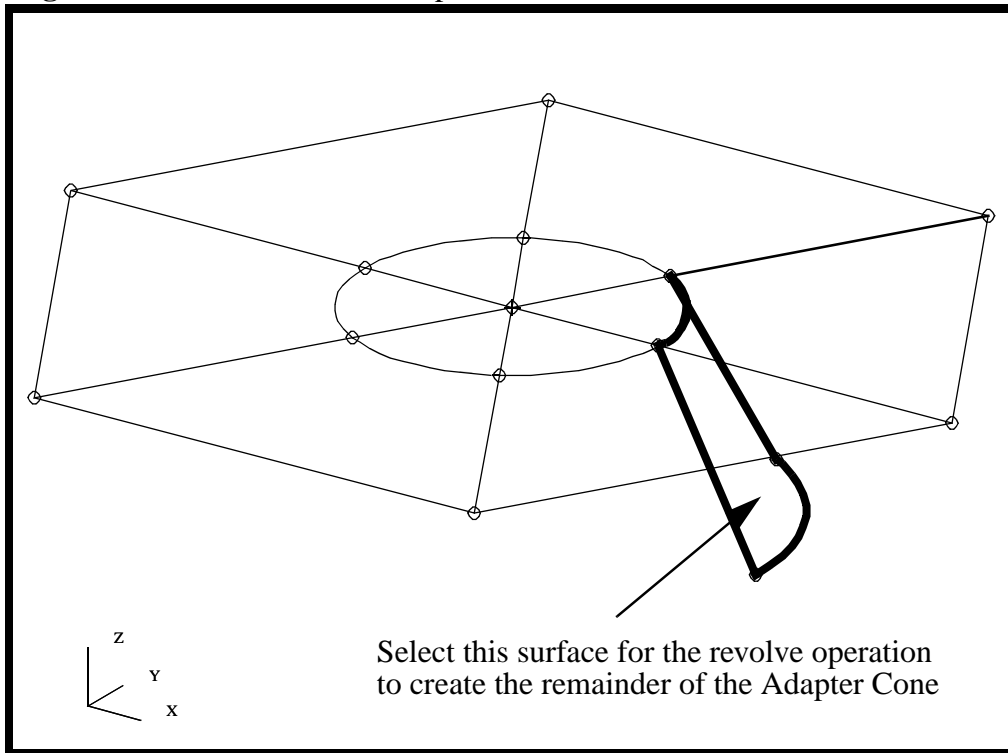

- Finally, we will complete the remainder of the Adapter Cone surfaces by rotating the newly created surface with an angle of 60 degrees and a repeat count of 5.

Create the Remainder of the Adapter Cone

<i>Action:</i>	Transform
<i>Object:</i>	Surface
<i>Method:</i>	Rotate

Rotation Angle

60.0

Repeat Count

5

Surface List

See Fig. 1.20



Change the model render style back to Smooth shaded using the Toolbar icons.



Smooth shaded

Your model should look like the figure below.

Figure 1.21. The Adapter Cone and Lower Platform geometry

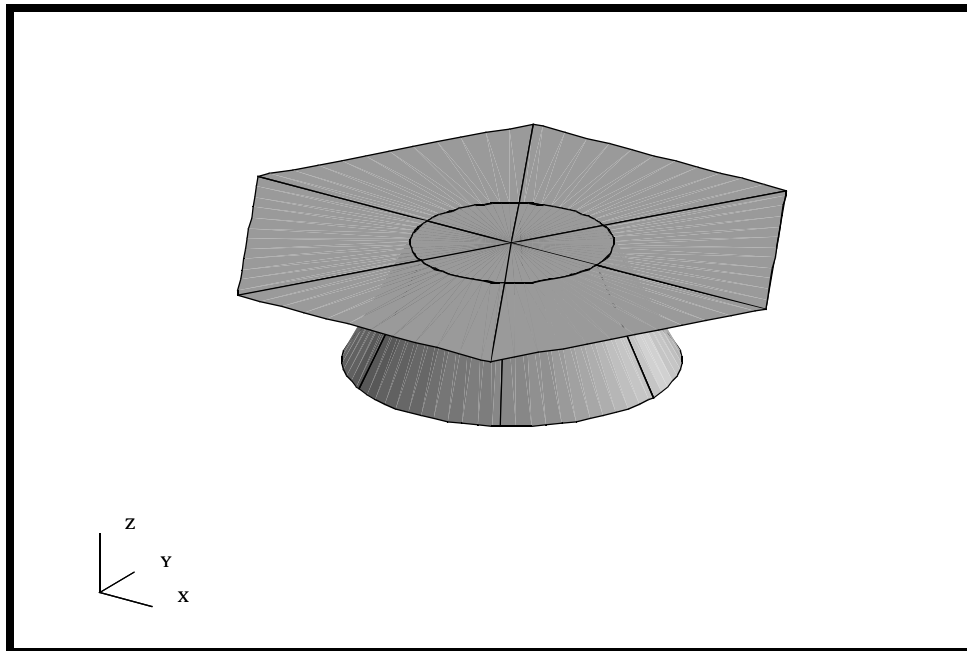

Create a Group for all of the Geometry

17. In this step, we will create a group for all geometry.

Group/Create...

New Group Name

All Geometry

Make Current

Unpost All Other Groups

Group Contents:

Add All Geometry

Apply

Cancel

Your model should look like the figure below.

Figure 1.22. The satellite model geometry.

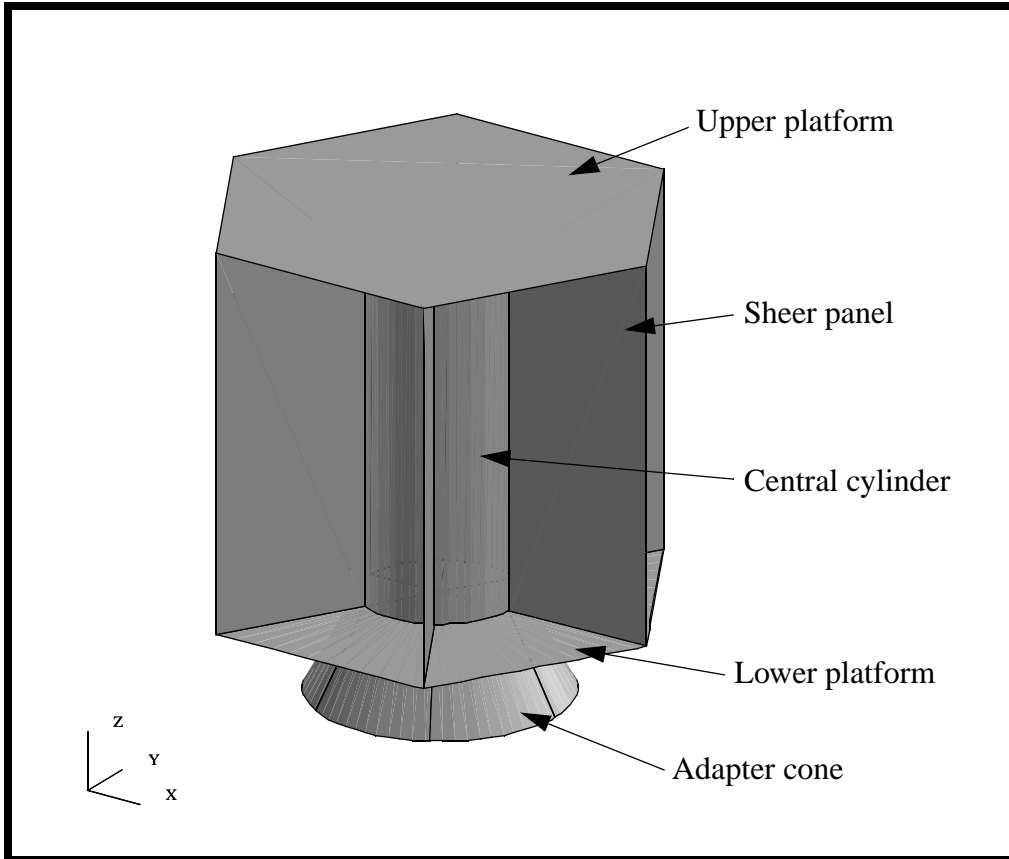

18. As an additional step, we will have you exercise the IGES export option from within MSC.Patran. Often times this is useful for transferring the geometry from MSC.Patran to another software package or using this as a geometric backup.

The creation of IGES entities is an additional step that you may want to perform. This step will take you through the procedure for creating an IGES file.

File/Export...

Format:

IGES

Create New File

satellite.igs

Apply

Export an IGES file of All the Geometry

MSC.Patran is capable of exporting every piece of geometry that can be created inside MSC.Patran, except for the Composite Trimmed Surface and Solids. In the case of solids, the faces are exported instead. For a further discussion on the specific IGES entities supported, please refer to the documentation.

Once the export is completed, you will be shown a Summary Window that lists the number and type of exported entities from MSC.Patran to IGES. Press OK to confirm the export.

IGES Export Summary

OK

In your UNIX window, you should see a **satellite.igs.01** file.

19. To complete this exercise, you will close the database.

File/Quit

This will exit MSC.Patran and close your file. Do not delete the database from your directory since you will use it for future exercises.

It should be noted that all changes made to the database are automatically saved; therefore, there is no need to perform a save operation.

**Close the
Database
and Quit
MSC.Patran**