

Exercise 3

Views of a Space Satellite

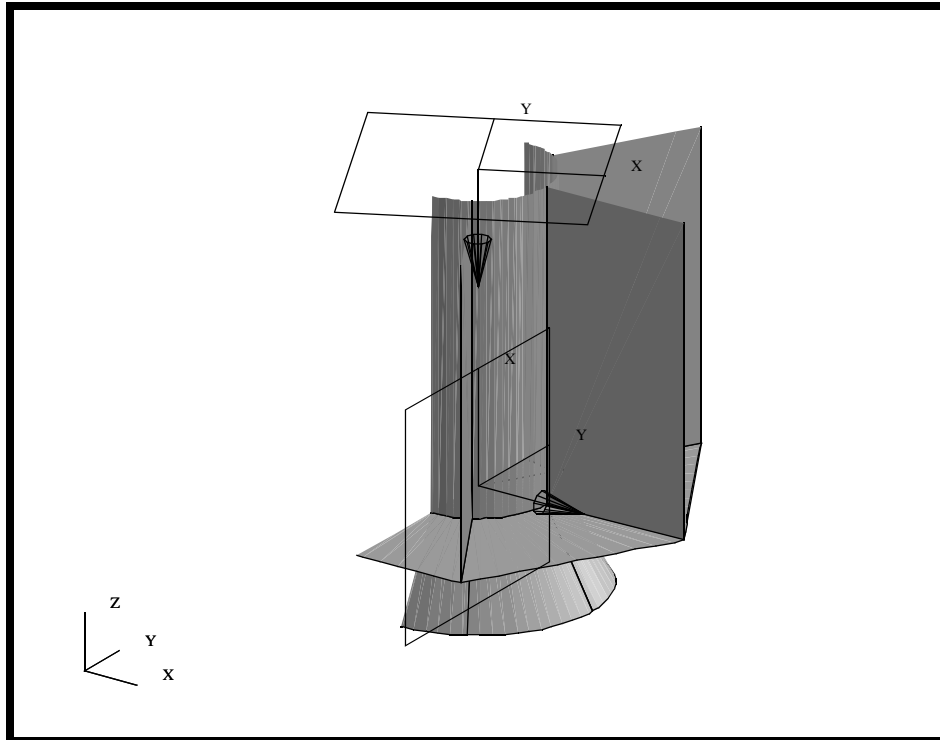

Objectives:

- To become familiar with different view options.
- To create and modify Z-Axis and Arbitrary Clipping planes.



Model Description:

The purpose of this exercise is to demonstrate the use of the Mouse movement, the Toolbar icons and the Main Form functions. Different views and render style of the Satellite model will be illustrated by using either the Mouse movement, the Toolbar icons, or the Main Form. You will also learn how to define Z-Axis and Arbitrary Clipping planes.

Suggested Exercise Steps:

- Create a new database called **view_satellite.db**.
- Import the geometry from the previously created IGES file.
- Change the model's render style using Toolbar icons or Main Form to shaded smooth.
- View the model from different angles using Toolbar icons or Main Form
- Use the middle mouse button to change the model's orientation.
- Change the mouse settings to translate and zoom in on the model, then change back to the default rotate X/Y setting.
- Use the Z-clipping planes to view a slice of the model.
- Change the view to MSC.Patran's predefined top view. Create two arbitrary clipping planes and name them **clip_1** and **clip_2**.
- Post and modify clipping planes' directions and locations as follows:

Table 1: Clipping Plane Locations

Name	Direction	Location	Move with model	Icon on
clip_1	<1, 0, 0>	[0, 0, 0]	Yes	Yes
clip_2	<0, 0, -1>	[0, 0, 50]	Yes	Yes

- Place the model in Isometric view position to observe the effects of the clipping planes.
- Turn off the "*Move With Model*" option and modify **clip_1**. Change to an Isometric view and notice the effect this has on

the model.

- Change the orientation of **clip_1** using the icons on the form.
- Unpost the clipping planes.
- Close and Exit MSC.Patran.

Exercise Procedure:

Open a New Database

1. Create a new database and called **view_satellite.db**.

File/New...

New Database Name

view_satellite

OK

New Model Preference

Tolerance

◆ **Default**

OK

Import the Satellite IGES Model

2. Import the IGES file that was created in the previous Satellite exercise.

File/Import...

Object:

Model

Source:

IGES

Import File

satellite.igs.01

Note: this can be selected from the IGES Files list.

Apply

Once the import file is completed, you will get a summary window listing what IGES entities were imported into MSC.Patran. Click **OK** on the **IGES Import Summary** window.

IGES Import Summary window

OK

3. Before we get started, let's change the view to Isometric view using the Toolbar icons.

**Iso 3 View**

4. Change the model's render style to Smooth shaded.

Using the Toolbar icons to change the render style.

**Smooth shaded**

You can also change the render style using the *Main Form* by selecting:

Display/Entity Color/Label/Render...

Render Style:

Shaded/Smooth

Apply

Cancel

Your model should look like the figure below.
Figure 2.1. Satellite model geometry from an imported IGES file.

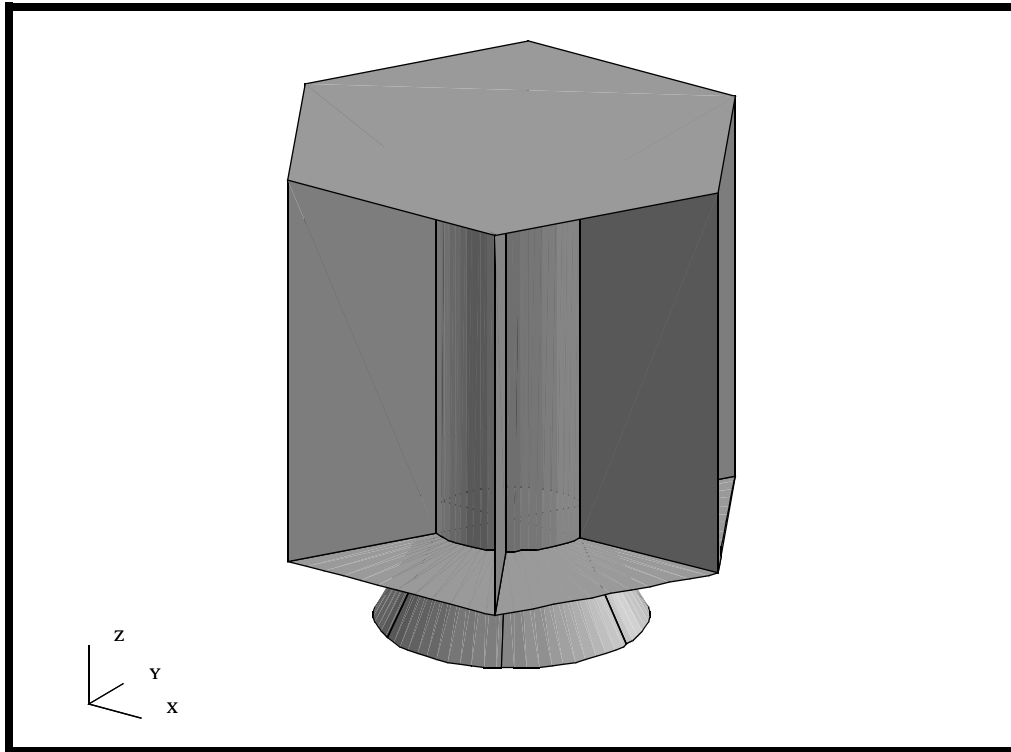

Re-Orient the Model

5. View the model from different angles.

Try viewing different orientations of the model by using the Toolbar icons as shown below.



Front view



Top view



**Back to
Iso 3 View**

You could have changed the views using the *Main Form* by selecting:

Viewing/Named View Options...

Select Named View

Pick the named view
that you want to
display

Close

- Use the middle mouse button to change the model's orientation.

Move the mouse cursor to the approximate center of the viewport. Click and hold down the center mouse button without sliding the mouse either horizontally or vertically. While holding the center mouse button down, slowly move the mouse to the right. Release the mouse button.

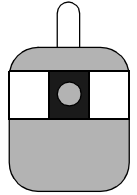

Repeat the same procedure but slowly move the mouse forward.

The control of the mouse movements can also be selected from the Main Form.

Preferences/Mouse...

Transformation Options...

You will see that the default rotations are relative to the screen coordinate system. Therefore horizontal and vertical movement of the mouse causes the model to rotate about the screen X- and Y-axes. Both forms are shown below for your reference.

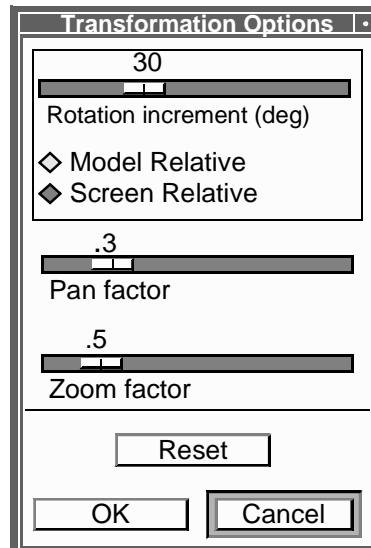
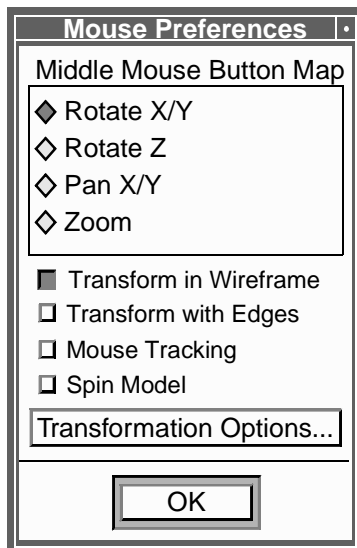

Cancel

OK

With this configuration, the middle mouse button will rotate your model in the XY plane of the screen coordinate system. You can change the middle mouse button to rotate about Z, pan and zoom the model, or use the Toolbar icons, as we will learn next.

Changing Mouse Settings

7. Change the middle mouse button settings to translate and zoom the model when moving the mouse, then change back to the default rotate X/Y setting.

From the Toolbar on the *Main Form*, click on the **Mouse translate XY** icon, shown below, which will change the function of the center mouse button to translate. Hold the middle mouse button down and move the mouse around to translate the model.

Next, click on the **Mouse zoom** icon, hold the middle mouse button down and zoom the model in and out.

To return to the default setting, click on the **Mouse rotate XY** icon.



Mouse translate XY



Mouse zoom



Mouse rotate XY

Clipping Planes

8. Return the model to Isometric view then use the Z-clipping planes to view a slice of the model. Turn off the Z-clipping planes.

Using the Toolbar icons to change the model to Isometric view.



Isometric 3 View



Fit View

Viewing/Clipping/Perspective...

Clipping

The Clipping toggle enables the MSC.Patran viewport Z-Axis front and back clipping planes. With the mouse, move the red clipping plane graphics towards the center of the blue model icon in the *Clipping/Perspective* form as shown below. This blue area represents the model's volume and position. The Z-Axis clipping planes are positioned along the screen Z-Axis.

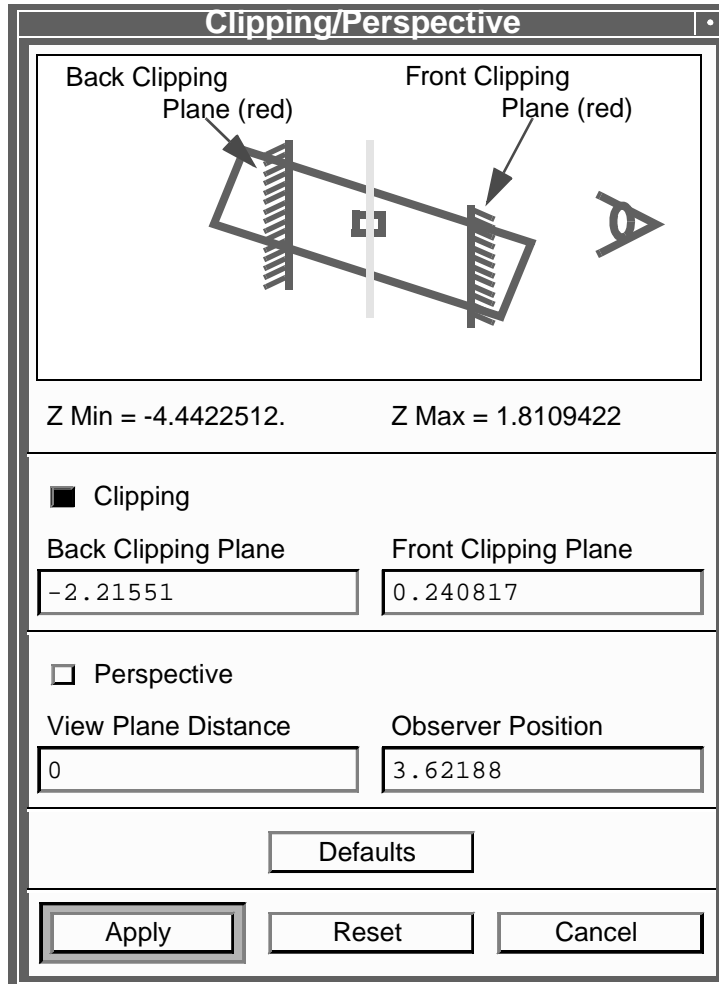

Using the mouse to change the model's view orientation. Notice that, as you move the model the Z-axis clipping planes remain stationary and the model passes through the clipping planes as shown in Figure 3.2.

Your clipping plane should be similar to the one shown below

Figure 3.2. The satellite clipped using Z-Axis Clipping

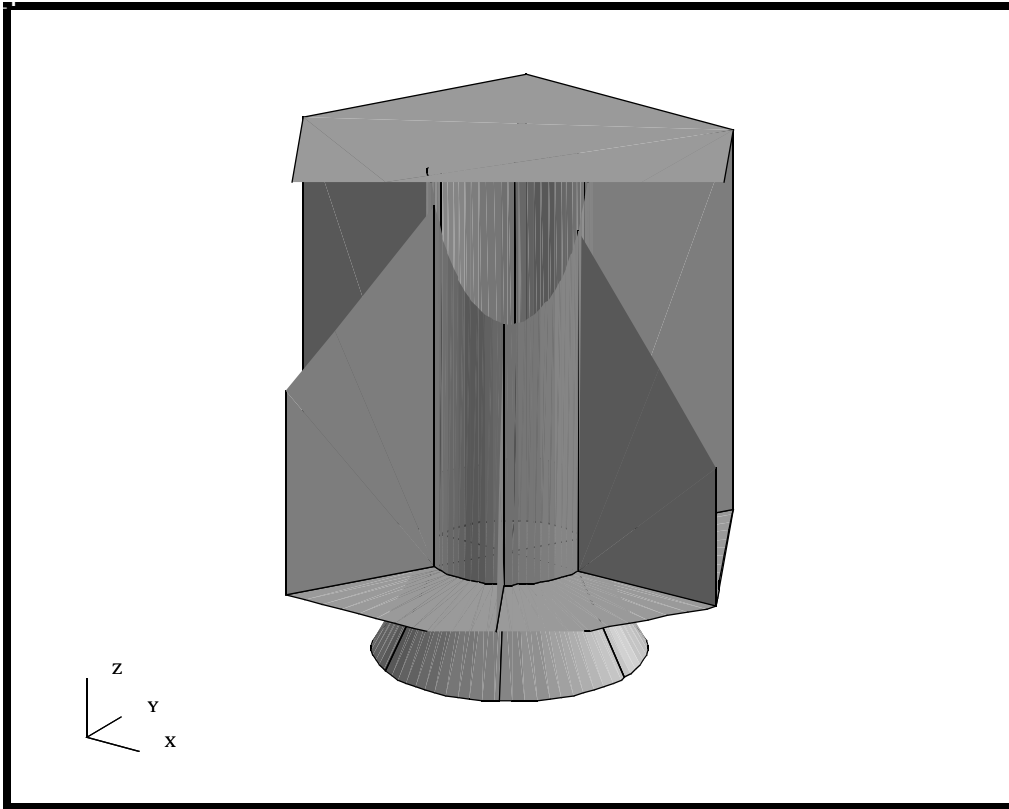

Turn off the Z-axis clipping planes and close the form.

Clipping

Cancel

9. Change the view to the bottom view. Create two arbitrary clipping planes and name them as **clip_1** and **clip_2**.

Using the Toolbar icons to change the view of the model.



Bottom view

Viewing/Arbitrary Clipping...

Create...

New Clipping Plane Name

clip_1

OK

Create...

New Clipping Plane Name

clip_2

OK

10. Modify and post each of the clipping planes that were just created.

First, let's post **clip_1** and modify its attributes.

Post/Unpost Clipping Planes

clip_1

clip_2

Target Clipping Plane:

clip_1

Clipping Plane Attributes

Move With Model

Display Direction Icon

This 'attaches' the plane to the model and displays the icon to show its position and direction. Now, let's define the plane direction and location.

Direction

< 1, 0, 0 >

Location

[0, 0, 0]

Apply

**Arbitrary
Clipping
Planes**

Your Satellite model should appear like the following figure.
Figure 3.3. The satellite with Arbitrary Clipping plane clip_1 applied to it.

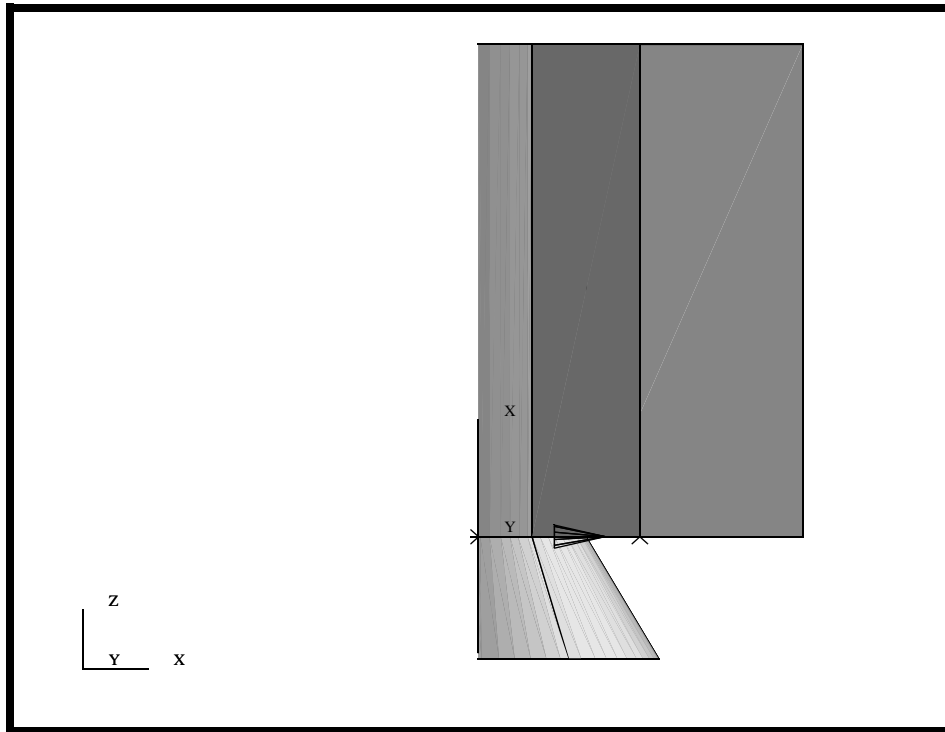

Now, we are going to repeat the steps we just performed for clipping plane #2. Let's start by posting **clip_1** and **clip_2** and modify **clip_2**'s attributes.

Post/Unpost Clipping Planes

clip_1
clip_2

Target Clipping Plane:

clip_2

Clipping Plane Attributes

Move With Model

Display Direction Icon

Direction

< 0, 0, -1 >

Location

[0, 0, 50]

Apply

Your Satellite model should be clipped as shown in the following figure.

Figure 3.4. The satellite with Arbitrary Clipping plane clip_1 and clip_2 applied to it.

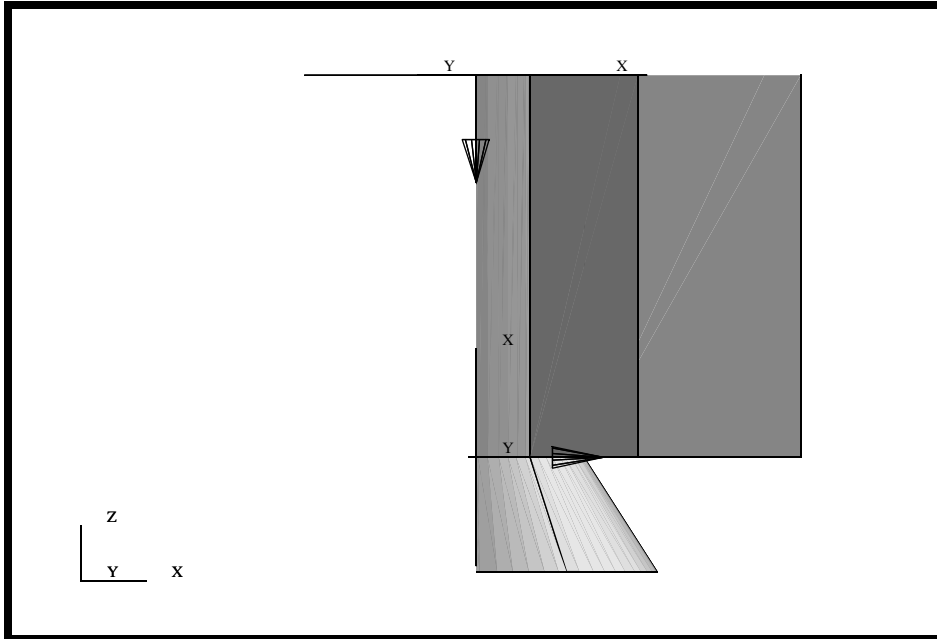

Now change the view to Isometric view using the Toolbar icons.



Isometric View 3

Your model should look like the figure shown below. Notice that the clipping planes moved with the model during the view change.

Figure 3.5. The satellite with clip_1 and clip_2 clipping planes applied to it as seen from an Isometric view.

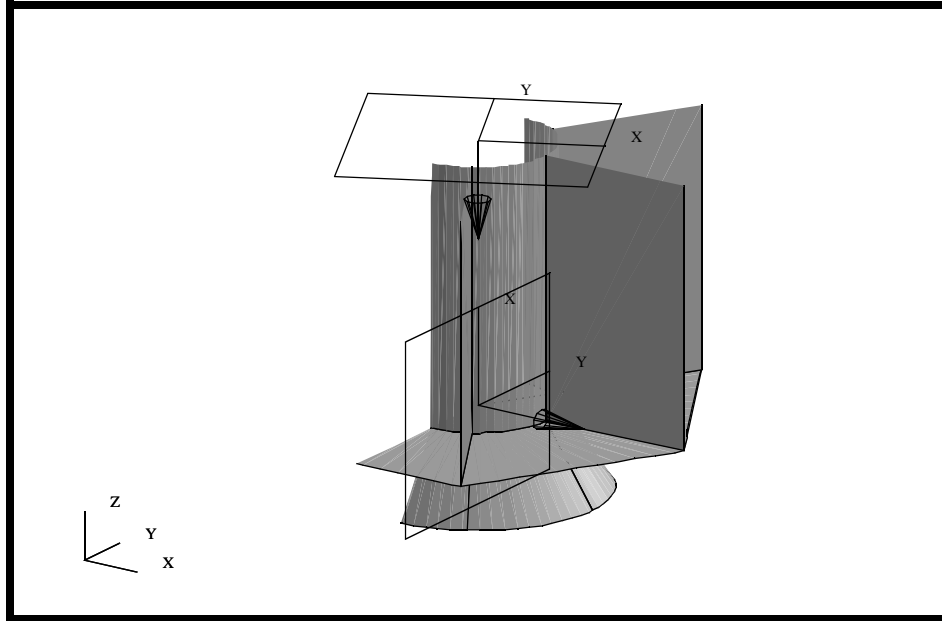

You can experiment by moving the model about using your center mouse button to observe that the clipping planes move with the model.

11. Return to the Bottom View and then change **clip_1** so that it no longer moves with the model. Notice the effect this has on the model.

First, change the view to the Bottom view using the Toolbar icons.



Bottom view

Now, modify **clip_1** so that it does not move with the model.

Target Clipping Plane:

clip_1

Clipping Plane Attributes

Move With Model

Apply

With the “*Move With Model*” option set to off, the clipping plane’s direction is defined with respect to the screen coordinate axis and not the model axis (default). Finally, change the view back to Isometric view using the Toolbar icons.



Isometric View 3

Again, you can experiment and move the model about using your center mouse button and observe how the properties of each clipping plane affects the model.

12. Unpost the clipping planes and return the model to the Isometric view.

Turn off **clip_1** and **clip_2** by unhighlighting their names in the *Post/Unpost Clipping Planes* list box. Note: you will need to select both of these by holding down on the Control Key.

Post/Unpost Clipping Planes

clip_1
clip_2

Hint: hold down the control key and select both items

Apply

Cancel

13. To complete this exercise, you will close the database.

File/Quit

This will exit MSC.Patran and close your file.

Close the Database and Quit MSC.Patran

