

## Exercise 5

# *Materials, Load Cases and LBC Assignment*

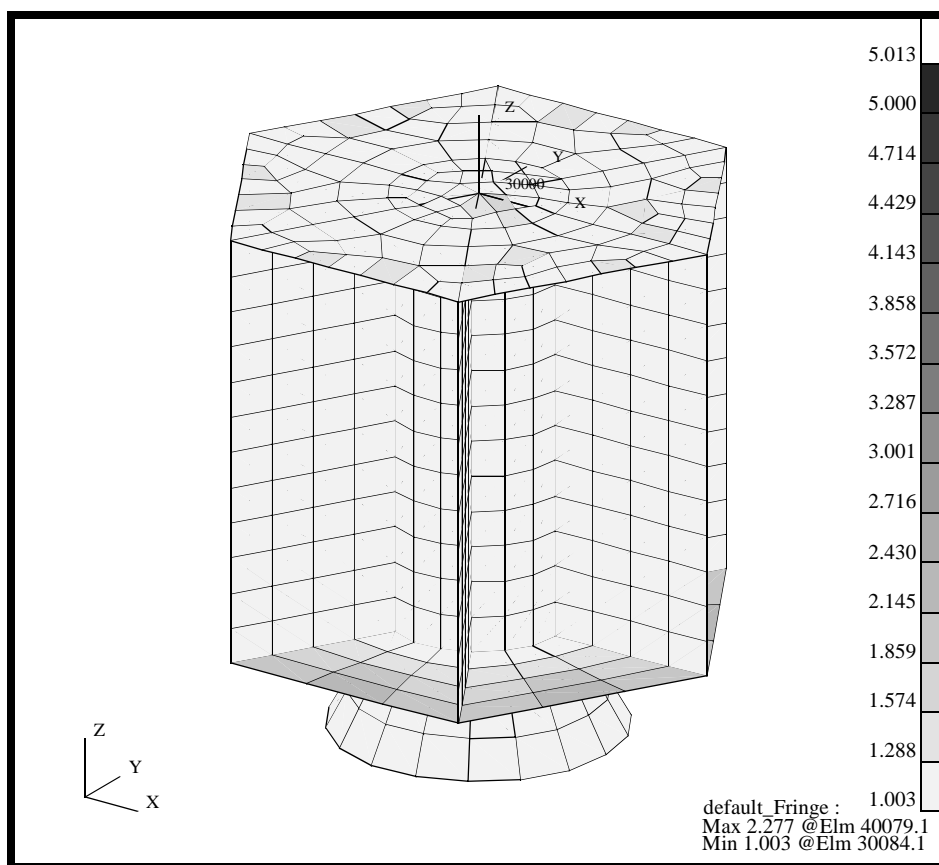

### Objectives:

- Perform a final verification of Quad elements.
- Prepare the model for analysis by creating material properties.
- Apply Loads and Boundary conditions and create two Loading conditions.



**Model Description:**

This exercise continues to prepare the Satellite model for analysis. You will check the Quad element's aspect ratio and define element and material properties. Finally, you will assign Loads and Boundary conditions to the model and setup two Loading conditions, one for a Modal analysis and one for a Static analysis.

**Suggested Exercise Steps:**

- Start MSC.Patran and open the **satellite.db** file.
- Verify the Quad element's aspect ratio using a threshold value of 5.0.
- Change the analysis coordinate system (Coord 20000) to the Launch CID by using FEM/Modify/Node.
- Create an Isotropic material, named **titanium**, which uses a Linear Elastic Constitutive Model. The material's Elastic Modulus, Poisson's Ratio and Density are 16E6, 0.16 and 0.27, respectively
- Create a Isotropic material named **aluminum**, which uses Linear Elastic Constitutive Model. The material's Elastic Modulus, Poisson's Ratio and Density are 10.5E6, 0.33 and 0.101, respectively.
- Create a simply supported displacement constraint, named **Launch constraint**, for all vertices on the outside edges of the Upper and Lower Platform. The displacement will be fixed in translation and free in rotation (i.e. ball joint).
- Define 3 inertial loadings according to the table below:

Load Name	Trans Accel	Analysis Coordinate System
Launch 1g + X	<386.4, 0, 0>	Coord 20000
Launch 1g + Y	<0, 386.4, 0>	Coord 20000
Launch 1g + Z	<0, 0, 386.4>	Coord 20000

- 
- Create two Load cases with the following properties:

<b>Load Case Name</b>	<b>LBC Scale Factor</b>	<b>Loads &amp; Boundary Conditions</b>
Launch Modal LC	1.0	launch constraint
Launch Static LC	1.0 2.0 2.0 -10.0	launch constraint Launch 1g + X Launch 1g + Y Launch 1g + Z

- Close and Exit MSC.Patran.

**Exercise Procedure:**

*Note: In most MSC.Patran forms, the default setting for the **Auto Execute** button is on; thus, you do not need to press **Apply**.*

1. Start MSC.Patran and open the **satellite.db** file.

**File/Open...**

Existing Database Name

**satellite.db****OK**

**Open the  
Satellite  
Database**

2. Before we get started, let's post the All Fem group.

**Group/Post...**

Select Groups to Post

**Adapter****All Fem****All Geometry****Central Cylinder****Lower Platform****Navigational Platform****Propulsion Block****Science Platforms****Shear Panels****Upper Platform****default\_group****Apply****Cancel**

Change the model view and render style using the following Toolbar.

**Isometric View 3****Smooth Shaded**

Your model should be similar to the display below.

**Figure 5.1.** All Fem displayed for the Satellite.

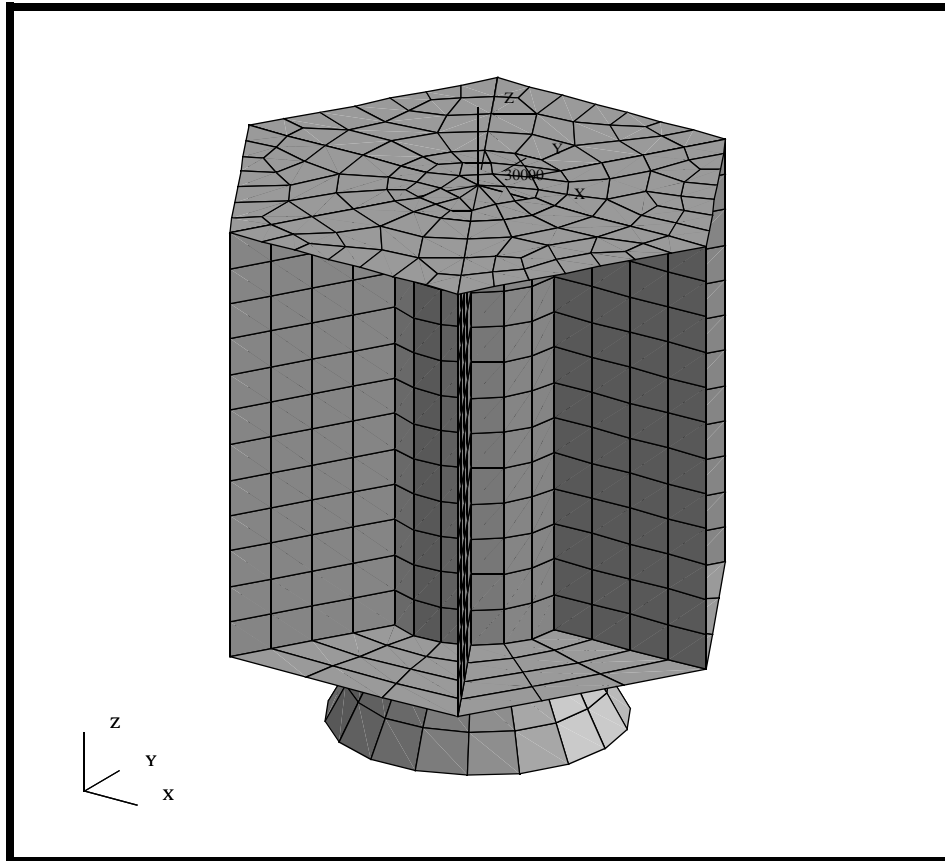

## Aspect Ratio Verification

3. Verify the Quad element's aspect ratio using a threshold value of 5.0.

### ◆ Finite Elements

*Action:*

**Verify**

*Object:*

**Quad**

*Test:*

**Aspect**

*Aspect Ratio*

**5.0**



**Apply**

This will color code the Quad4 elements based on their aspect ratio. Any element with an aspect ratio greater than or equal to your threshold value, 5.0, will be colored red according to the default spectrum.

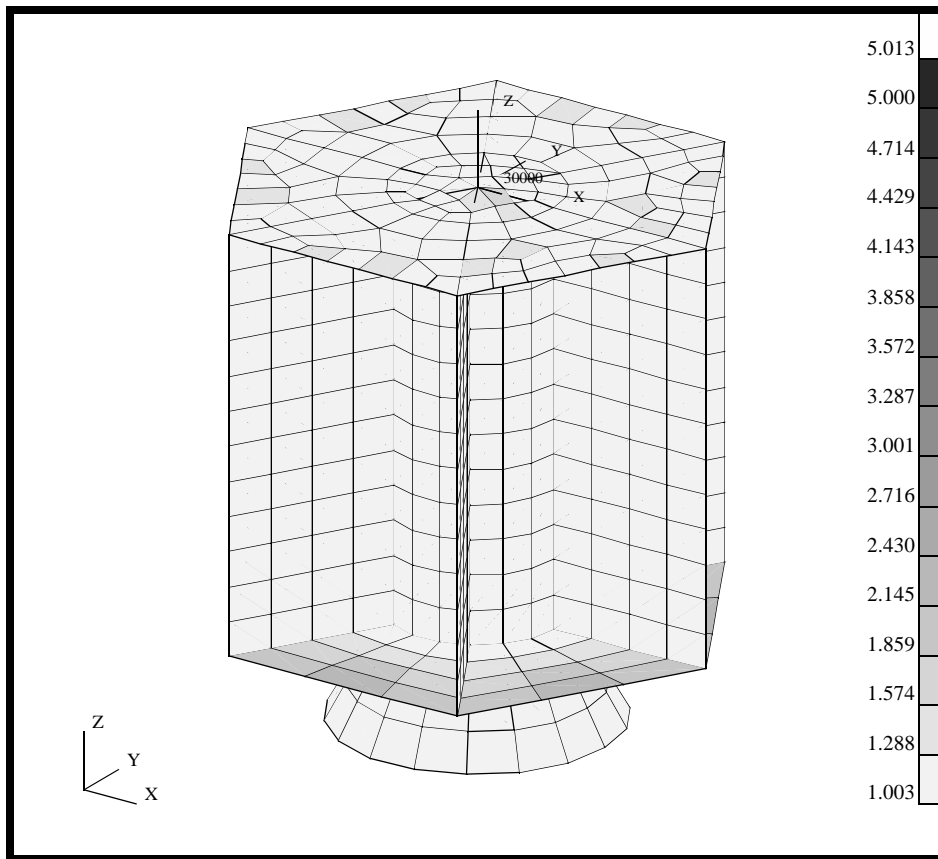
**Figure 5.2.** The Quad4 Aspect Ratio Verification Plot.

A summary of the minimum and maximum aspect ratio for the elements is located in the lower right hand corner of the viewport.

**Reset Graphics**

## Modify Nodal Analysis CID

- In this step, you will change the Nodal Analysis Coordinate System to the Launch coordinate system (CID 20,000).

Before we get started, let's re-orient the model in a more convenient orientation to pick the Analysis Coordinate System. Additionally, to better visualize the finite elements and coordinate frame, change the render style using the Toolbar icons.



**Isometric View 4**



**Hidden Line**

Your model should now look like the following figure.

**Figure 5.3.** Isometric View showing the Launch CID.

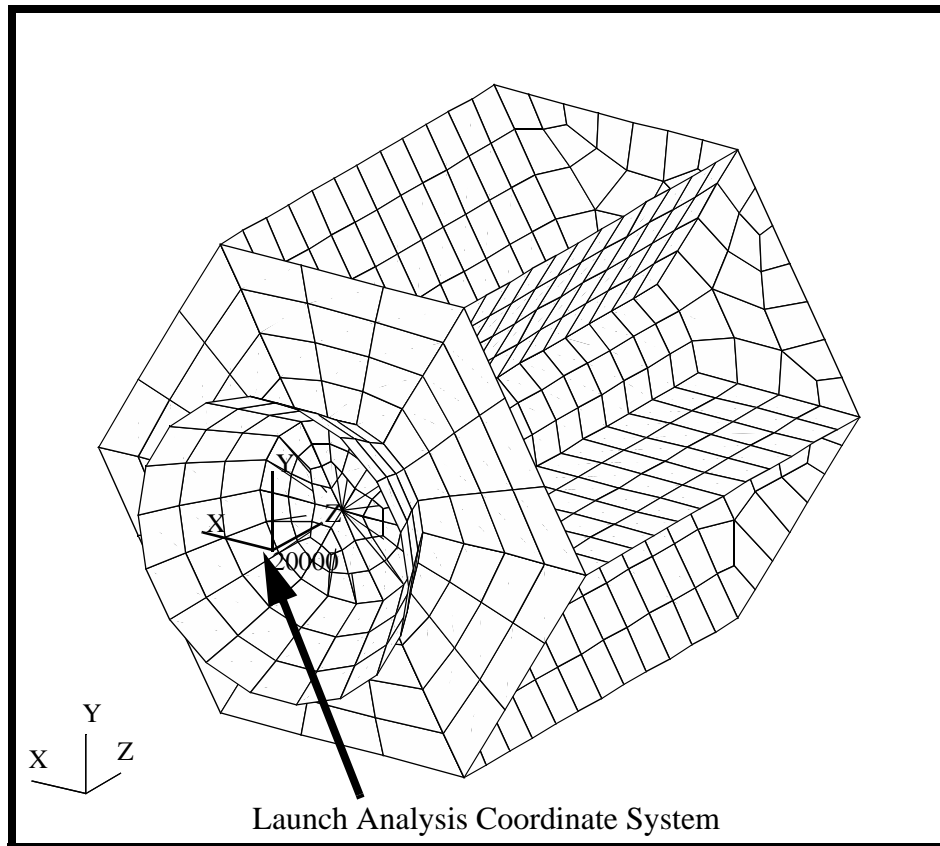

Now, let's redefine the Analysis Coordinate Frame.

*Action:*

**Modify**

<i>Object:</i>	<input type="text" value="Node"/>
<i>Method:</i>	<input type="text" value="Edit"/>
<i>Nodal Attributes</i>	<input checked="" type="checkbox"/> <b>Analysis Coordinate Frame</b>
<i>Analysis Coordinate Frame</i>	<input type="text" value="Coord 20000"/>
<i>Node List</i>	<input type="text" value="Select ALL nodes in the current viewport"/>
<input type="button" value="Apply"/>	

We have now completed all the work that we need to do on the model in Finite Elements section. Let's define the materials and any loadings that will be required to model a Launch configuration.

5. Create an Isotropic material, named **titanium**. The material's Elastic Modulus, Poisson's Ratio and Density are 16E6, 0.27 and 0.16, respectively.

**Create Titanium & Aluminum Material Properties**

◆ **Materials**

<i>Action:</i>	<input type="text" value="Create"/>
<i>Object:</i>	<input type="text" value="Isotropic"/>
<i>Method:</i>	<input type="text" value="Manual Input"/>
<i>Material Name</i>	<input type="text" value="titanium"/>
<input type="button" value="Input Properties..."/>	
<i>Constitutive Model:</i>	<input type="text" value="Linear Elastic"/>
<i>Elastic Modulus =</i>	<input type="text" value="16E6"/>
<i>Poisson Ratio =</i>	<input type="text" value="0.27"/>
<i>Density =</i>	<input type="text" value="0.16"/>
<input type="button" value="OK"/>	
<input type="button" value="Apply"/>	

Now, let's create a second material, named **aluminum**. The material's Elastic Modulus, Poisson's Ratio and Density are 10.5E6, 0.33 and 0.101, respectively.

<i>Material Name</i>	<b>aluminum</b>
<b>Input Properties...</b>	
<i>Constitutive Model:</i>	<b>Linear Elastic</b>
<i>Elastic Modulus =</i>	<b>10.5E6</b>
<i>Poisson Ratio =</i>	<b>0.33</b>
<i>Density =</i>	<b>0.101</b>
<b>OK</b>	
<b>Apply</b>	

## Define the Launch Constraints

- Let's create all the Load and Boundary Conditions that will be needed to model a Launch condition for the Satellite. We will start by defining the Launch constraints.

We will define two Loading conditions. The first will be a constraint set and the second will be the inertial loadings. Let's start by posting the groups that need to be defined the displacement conditions, the Upper and Lower Platforms.

### Group/Post...

*Select Groups to Post*

<b>Adapter</b>
<b>All Fem</b>
<b>All Geometry</b>
<b>Central Cylinder</b>
<b>Lower Platform</b>
<b>Navigational Platform</b>
<b>Propulsion Block</b>
<b>Science Platforms</b>
<b>Shear Panels</b>
<b>Upper Platform</b>
<b>default_group</b>

<b>Apply</b>
--------------

When one group is posted, MSC.Patran assumes that group is the current group. However, when more than one group is posted, MSC.Patran will require you to define a current group. The current

group is used to collect any new entities created. In this step, we will not be defining any new geometry or finite elements. We will select the Lower Platform as the current group.

*Current Group Selection*

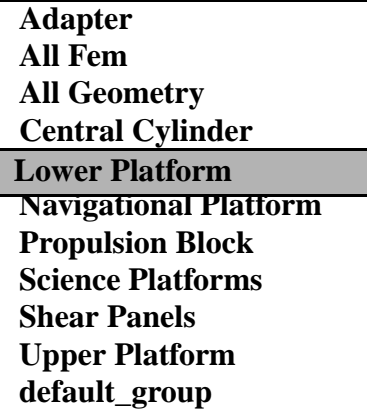

**OK**

**Cancel**

Change the view and render style of the model using the Toolbar icons.



**Isometric View 3**



**Wireframe**

Finally, your model should now look like the figure below.

**Figure 5.4.** Constraints for satellite on Upper and Lower Platform.

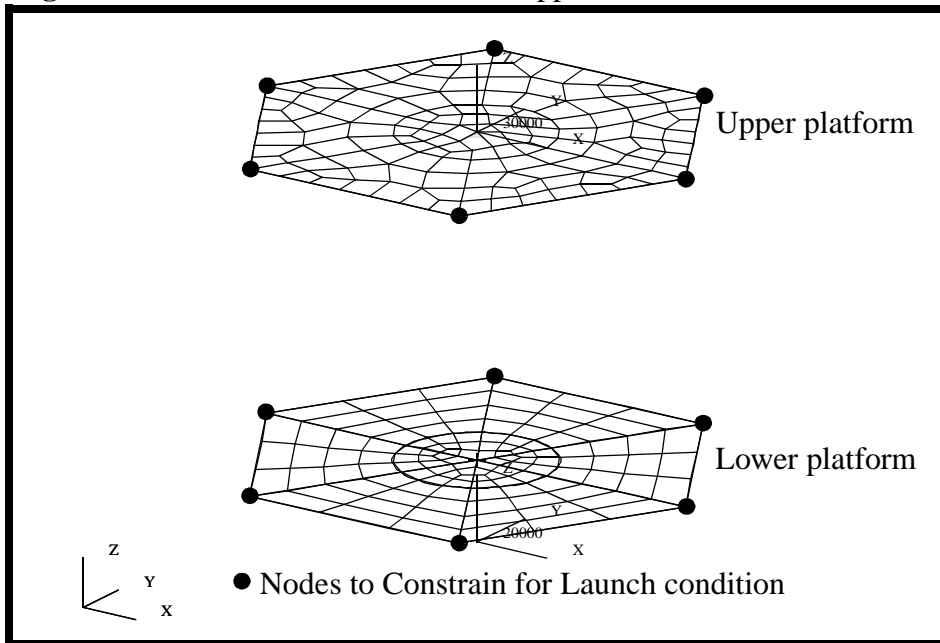

Define the Launch constraints for the Satellite.

◆ **Loads/BCs**

Action:

**Create**

Object:

**Displacement**

Type:

**Nodal**

New Set Name

**Launch constraint**

**Input Data...**

Translations <T1 T2 T3>

<0, 0, 0>

Rotations <R1 R2 R3>

< >

Analysis Coordinate Frame

**Coord 20000** ↗

**OK**

**Select Application Region...**

Geometry Filter

◆ **FEM**

Select Nodes

Select nodes shown in Figure 4.4

Note: You need to hold the *Shift* key down to pick all the nodes at the same time.

Add

OK

Apply

Your model should now look like the figure below.

**Figure 5.5.** Launch Constraints applied to the satellite.

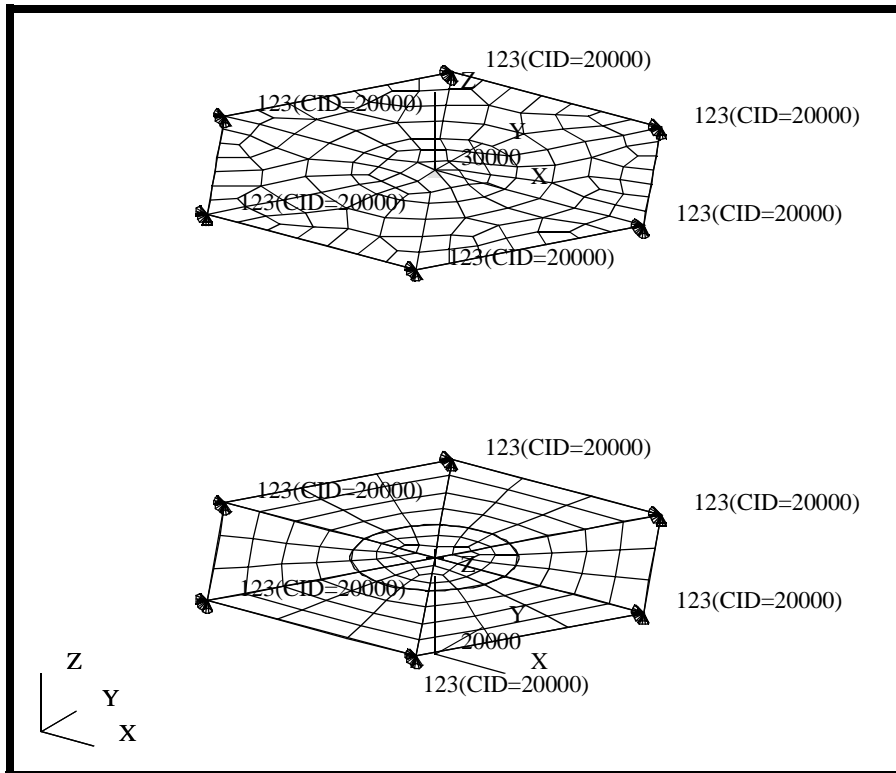

**Define the  
Launch  
Acceleration**

- We will create an inertial loading due to the Launch accelerations. We will define three separate loadings, a unit *g* load in the X, Y and Z directions. In a later step, we will use create subcases that are scaled multiples of these loadings.

We will define 3 inertial loadings as shown in the table below. It should be noted, the gravity constant for this problem is  $1\ g = 386.4$ .

Load Name	Trans Accel	Analysis Coordinate System
Launch 1g + X	<386.4, 0, 0>	Coord 20000
Launch 1g + Y	<0, 386.4, 0>	Coord 20000
Launch 1g + Z	<0, 0, 386.4>	Coord 20000

We will start by creating a unit *g* load in the X direction. The inertial loading is applied to the entire model. Since there is only one possible Application Region (All Finite Elements); there is no need to define one, MSC.Patran will assume applications to the entire model.

Action:

Object:

Type:

New Set Name

Trans Accel <A1 A2 A3>

Rot Velocity <w1 w2 w3>

Rot Accel <a1 a2 a3>

Analysis Coordinate Frame

Repeat the above step for the Y and Z directions according to the table above. Make sure to update the New Set Name and Translation Acceleration Vector.

## Define Two Load Cases

8. Finally, we will define two load cases for this model. The first load case contains only the Launch constraints which will be used as a constraint set in a Modal analysis. The second load case will contain the Launch constraints and a combined set of inertial loadings. This load case will be used for Static analysis.

We will make use of the capability of scaling the LBC's. We will create the following load combination; where the gravitational vector is defined as  $\langle 2, 2, -10 \rangle$ . If we were making several load cases based on accelerations, this procedure would be very handy.

Load Case Name	LBC Scale Factor	Loads & Boundary Conditions
Launch Modal LC	1.0	Launch Constraint
Launch Static LC	1.0	Launch Constraint
	2.0	Launch 1g + X
	2.0	Launch 1g + Y
	-10.0	Launch 1g + Z

We will start by defining the Modal Load case, which will be used to determine the modal frequencies of the spacecraft in a launch configuration.

### ◆ Load Cases

Action:

Create

Load Case Name

Launch Modal

Load Case Type:

Static

Assign/Prioritize Loads/BCs

Select Individual Loads/BCs

Displ\_Launch constraint

The Displacement Launch condition should now have been added to your spreadsheet.

OK

Apply

Let's create the second Load case to model a  $\langle 2, 2, -10 \rangle$  g static loading condition.

Load Case Name

Launch Static

---

*Load Case Type:*

**Static**

**Assign/Prioritize Loads/BCs**

We will now create the static load condition. We will first pick the load and boundary conditions that make up the load case, then we will scale each of the individual inertial loadings.

*Select Individual Loads/BCs*

**Displ\_Launch constraint**

*Select Individual Loads/BCs*

**Inert\_Launch 1g + X**

*Select Individual Loads/BCs*

**Inert\_Launch 1g + Y**

*Select Individual Loads/BCs*

**Inert\_Launch 1g + Z**

From the list of Assigned Loads/BCs spreadsheet, change the following scale factors

**Scale Factor**

*Launch Constraint*

**1.0**

*Launch 1g +X*

**2.0**

*Launch 1g +Y*

**2.0**

*Launch 1g +Z*

**-10.0**

The spreadsheet should now show the 3 inertial loading conditions along with the displacement constraint. Additionally, the spreadsheet also indicates the correct scale factor.

**OK**

**Apply**

---

**Close the  
Database  
and Quit  
MSC.Patran**

9. To complete this exercise, you will close the database.

**File/Quit**

This will exit MSC.Patran and close your file. Do not delete the database from your directory since you will use it for future exercises.