

WORKSHOP 5

Views of a 3-D Clevis

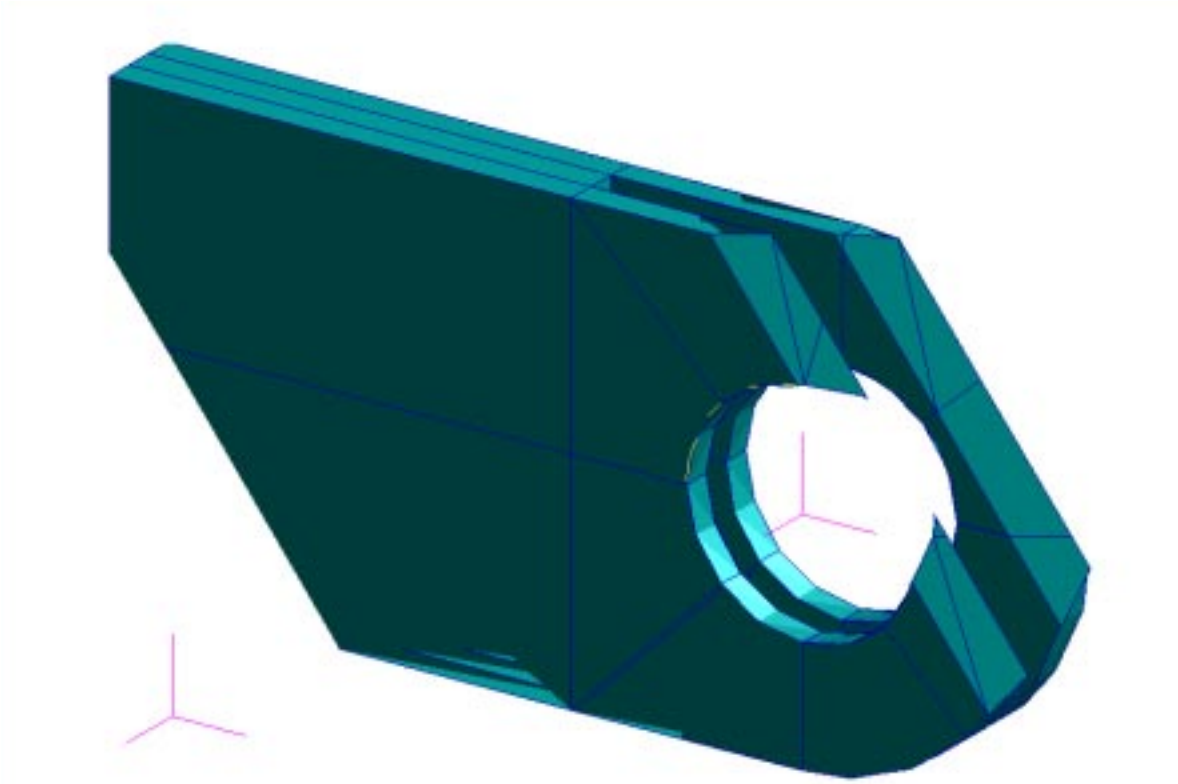

Objectives:

- To become familiar with different view options.
- To create and modify z-axis and arbitrary clipping planes.



Model Description:

In this exercise you will view the 3-D clevis model from different positions using mouse movement and Named View Options, and change the render style. You will also learn how to define z-axis and arbitrary clipping planes. These are used to view cross sections of the model.

Suggested Exercise Steps:

- Open the old database **clevis.db**.
- Change the model's render style to smooth shaded.
- View the model from different angles.
- Use the middle mouse button to change the model's orientation
- Change the mouse settings to translate and zoom in on the model, then change back to the default rotate x/y setting.
- Use the z-clipping planes to view a slice of the model.
- Change the view to MSC.Patran's predefined top view. Create two arbitrary clipping planes and name them **clip_1** and **clip_2**.
- Modify their direction and location as follows:

Table 1:

Name	Direction	Location	Move with model	Icon on
clip_1	<-1, 0, -1>	[-1, 0, 0]	Yes	Yes
clip_2	<1, 0, 0>	[-3, 0, 0]	Yes	Yes

- Change to isometric view to observe the effects of the clipping planes.
- Return to the top view and then change clip_2 so that it no longer moves with the model. Change to isometric view and notice the effect this has on the model.
- Change the orientation of clip_1 using the icons on the form.
- Unpost the clipping planes and return the model to the isometric view and wireframe render style.

Exercise Procedure:

1. Open the old database **clevis.db**.

File/Open...

Existing Database Name

clevis.db

OK

It may be necessary to click on the filter button to update the Database List so **clevis.db** is displayed.

2. Change the model's render style to smooth shaded.

Click on the smooth shaded icon on the *Main Form* to change the render style.



You can also do this on the *Main Form* by selecting

Display/Entity Color/Label/Render

Render Style:

Shaded/Smooth

Apply

Your model should look like this

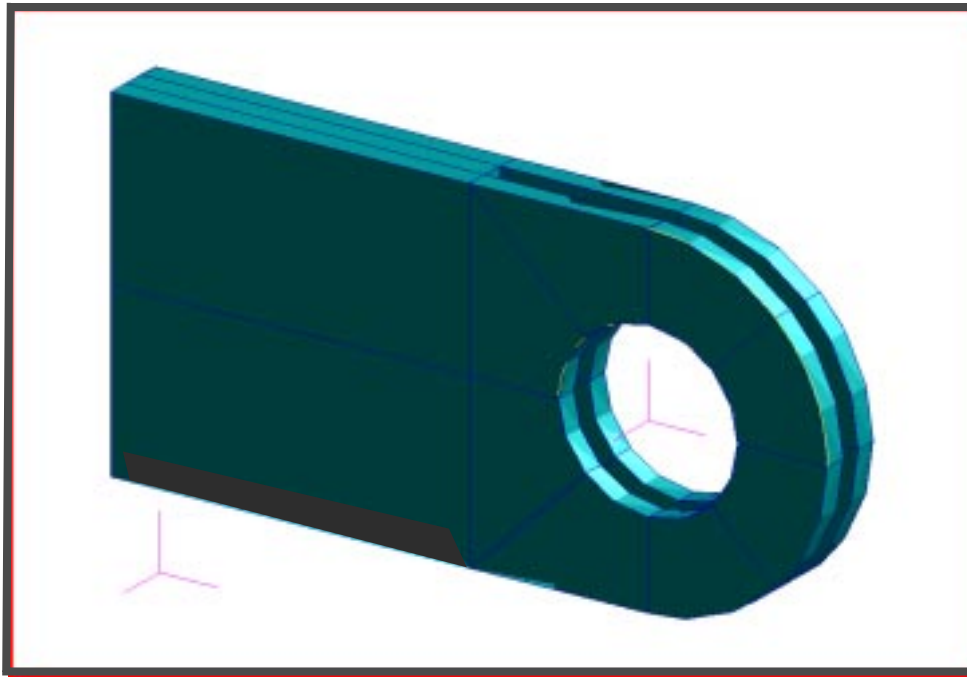

3. View the model from different angles.

Try viewing different orientations of the model by using the icons on the *Main Form* as shown below.



Front View



Top View



Back to
Isometric View

You can also access these views through **Viewing/Named View Options**.

4. Use the middle mouse button to change the model's orientation

Move the mouse cursor to the approximate center of the viewport. Click and hold down the center mouse button without sliding the mouse either horizontally or vertically. While holding the center mouse button down slowly move the mouse to the right. Release the mouse button.

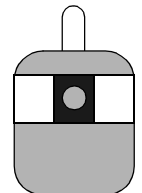

Re-Orient the Model

Repeat the same procedure but slowly move the mouse forward.

Preferences/Mouse...

Transformation Options...

You will see that the default rotations are relative to the screen coordinate system. Therefore horizontal and vertical movement of the mouse causes the model to rotate about the screen x- and y-axes. Both forms are shown below for your reference.

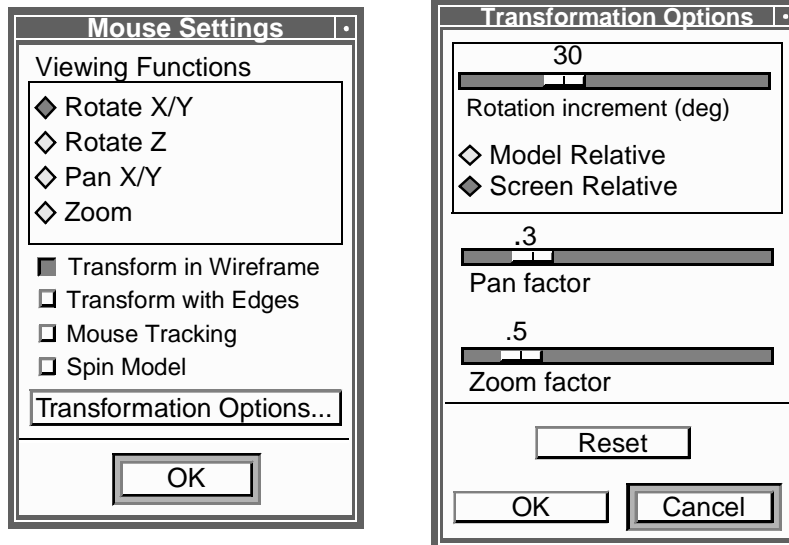

Cancel

OK

With this configuration, the middle mouse button will rotate your model in the XY plane of the screen coordinate system. You can change the middle mouse button to rotate about Z, pan and zoom the model, or use the *Main Form* icons, as we will learn next.

5. Change the middle mouse button settings to translate and zoom the model when moving the mouse, then change back to the default rotate x/y setting.

From the toolbar on the *Main Form*, click on the **Mouse translate XY** icon which will change its function to translate. Hold the middle mouse button down and move the mouse around to translate the

Changing Mouse Settings

model. Next, click on the **Mouse zoom** icon, hold the middle mouse button down and zoom the model in and out. To return to the default setting, click on the **Mouse rotate XY** icon.



Mouse translate XY



Mouse zoom



Mouse rotate XY

6. Return the model to an isometric view then use the z-clipping planes to view a slice of the model. Turn off the z-clipping planes.

Click on the **Iso 1 View** icon from the *Main Form* to return to an isometric view.



Iso 1 View

Clipping Planes

Viewing/Clipping/Perspective...

Clipping

These radio button switches to enable the MSC.Patran z-axis front and back clipping planes and face capping. With the mouse move the red clipping plane graphics towards the center of the blue clevis model icon in the *Clipping/Perspective* form as shown in the form below. The z-axis clipping planes are positioned along the screen z-axis.

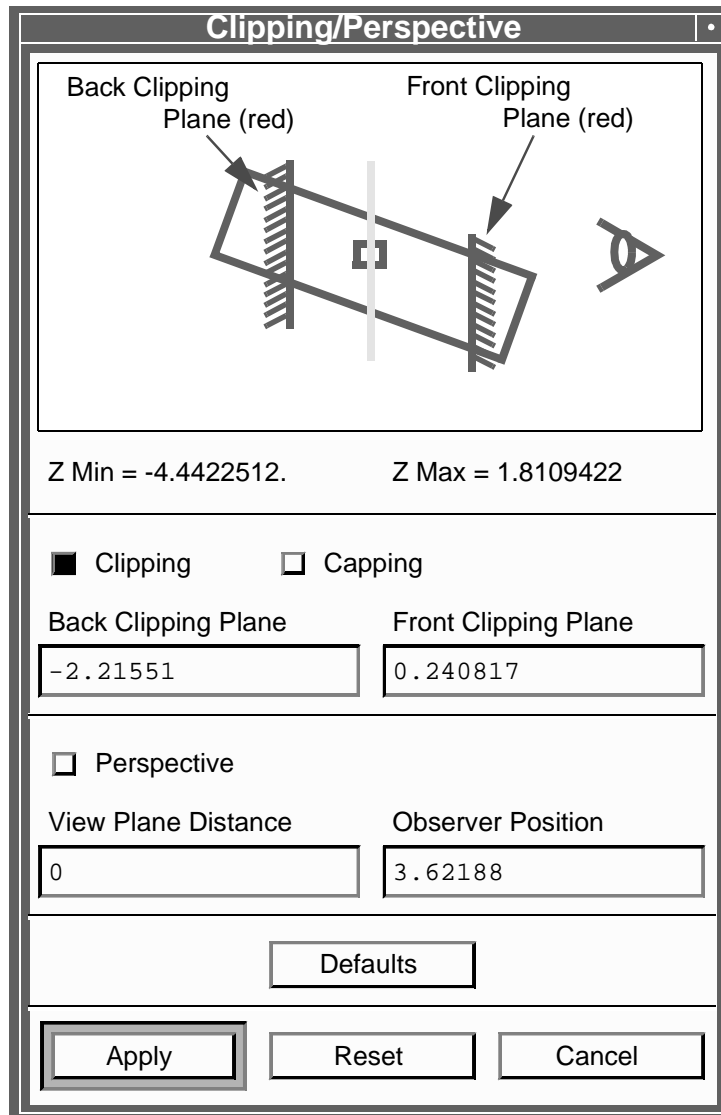

Using the mouse, change the model's view orientation. Notice that as you move the model the z-axis clipping planes remain stationary and the model passes through the clipping planes as shown in the figure below.

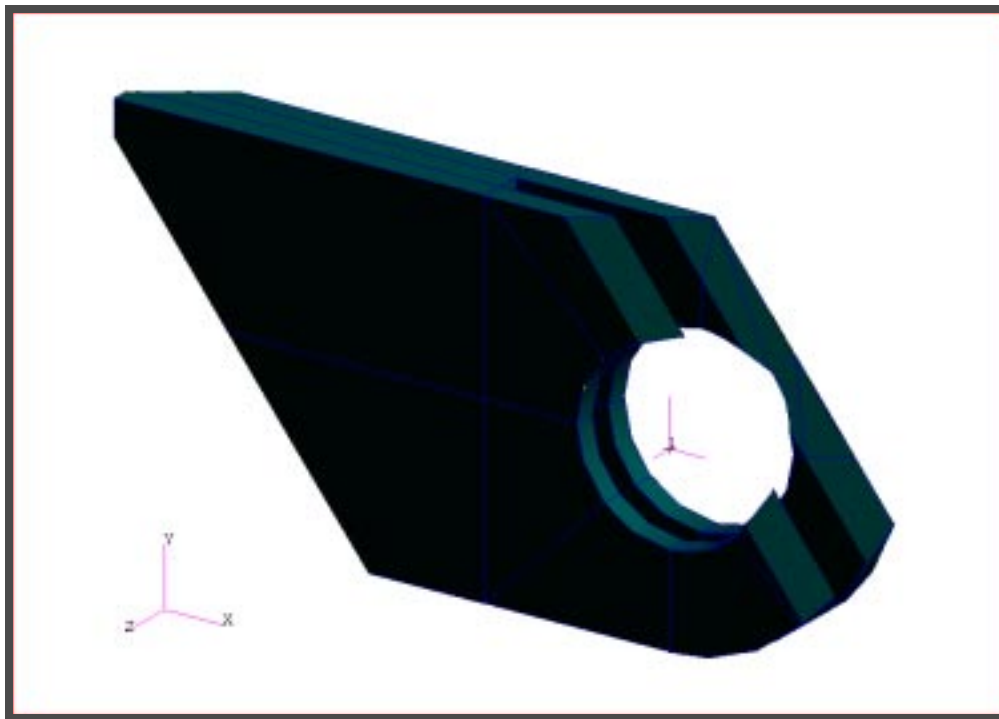

Turn off the z-axis clipping planes by clicking on the **Clipping** switch. Click on **Cancel** to close the form.

- Change the view to the top view. Create two arbitrary clipping planes and name them **clip_1** and **clip_2**.

Click on the **Top View** icon from the *Main Form*.



Viewing/Arbitrary Clipping...

New Clipping Plane Name

Arbitrary Clipping Planes

Repeat this process with the name **clip_2**.

8. Modify and post each of the clipping planes just created using the settings shown in Table 1 on page 5-3.

In the *Post/Unpost Clipping Planes* listbox highlight the **clip_1** clipping plane.

Let us review the highlighting procedure (posting) in a list box. The selection is usually done as a combination of a mouse click simultaneously with a key board press. The following table summarizes these combination.

Item(s) to pick	Method
Single item pick.	point + click L.M.B.*
A block of items.	click L.M.B. at top item, while the button is down scroll down to the last item.
Multiple picking of individual items.	use L.M.B. + shift key on the first and last item in the block.
Random picking of item.	use L.M.B. + control key at every item to be picked.
To unpost an item	L.M.B. + control key
*L.M.B. is left mouse button	

Change the *Target Clipping Plane* option button to **clip_1**.

Target Clipping Plane:

clip_1

Clipping Plane Attributes

Move With Model

Display Direction Icon

This 'attaches' the plane to the model and displays the icon to show its position and direction.

Direction

< -1, 0, -1 >

Location

[-1, 0, 0]

Apply

Your Clevis model should appear like the following figure.

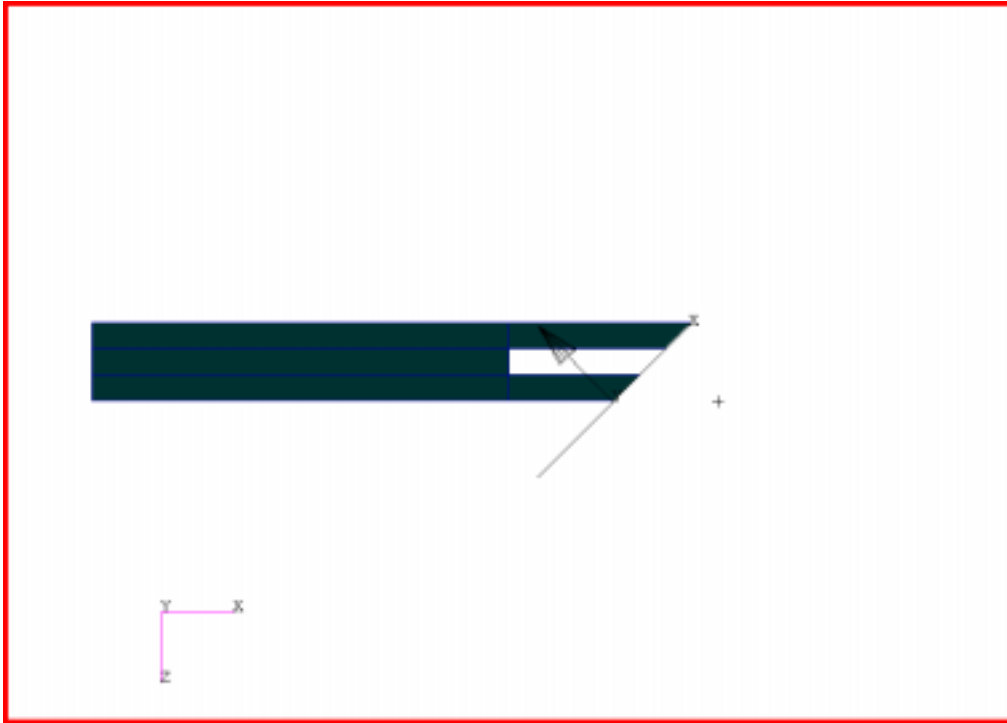

Next, change the *Target Clipping Plane* option menu to **clip_2**. In the *Post/Unpost Clipping Plane* listbox highlight **clip_1** and **clip_2** clipping planes.

Target Clipping Plane:

clip_2

Clipping Plane Attributes:

Move With Model

Display Direction Icon

Direction

< 1, 0, 0 >

Location

[-3, 0, 0]

Apply

Your clevis model should be clipped as shown in the following figure.

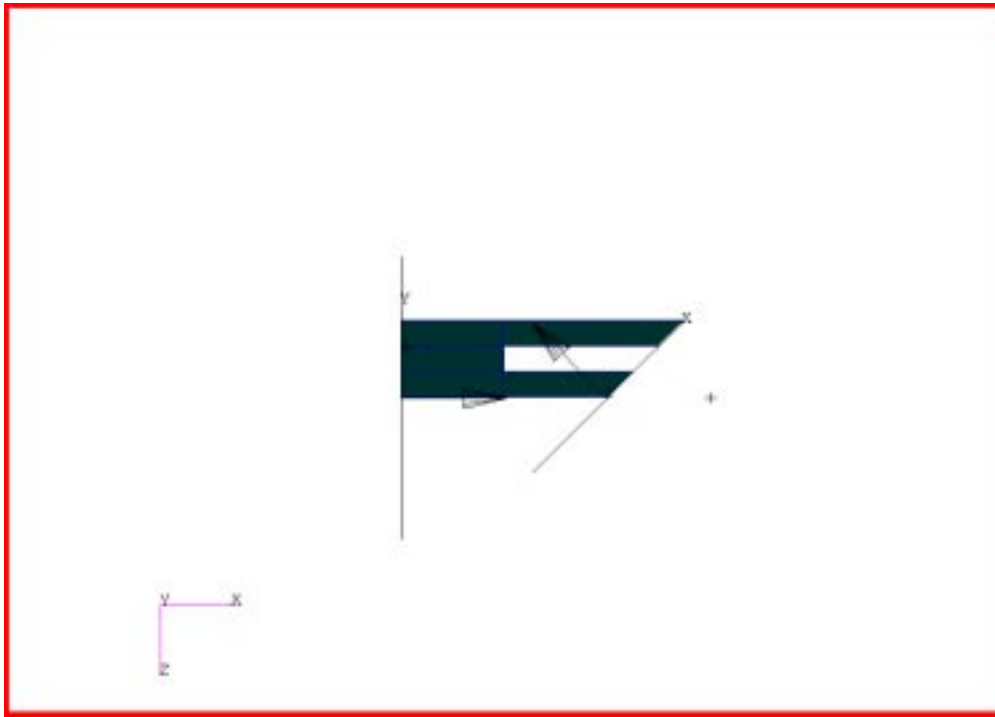

Using the *Main Form* icon **Iso 1 View**, change to an isometric view to observe the effects of the two clipping planes.

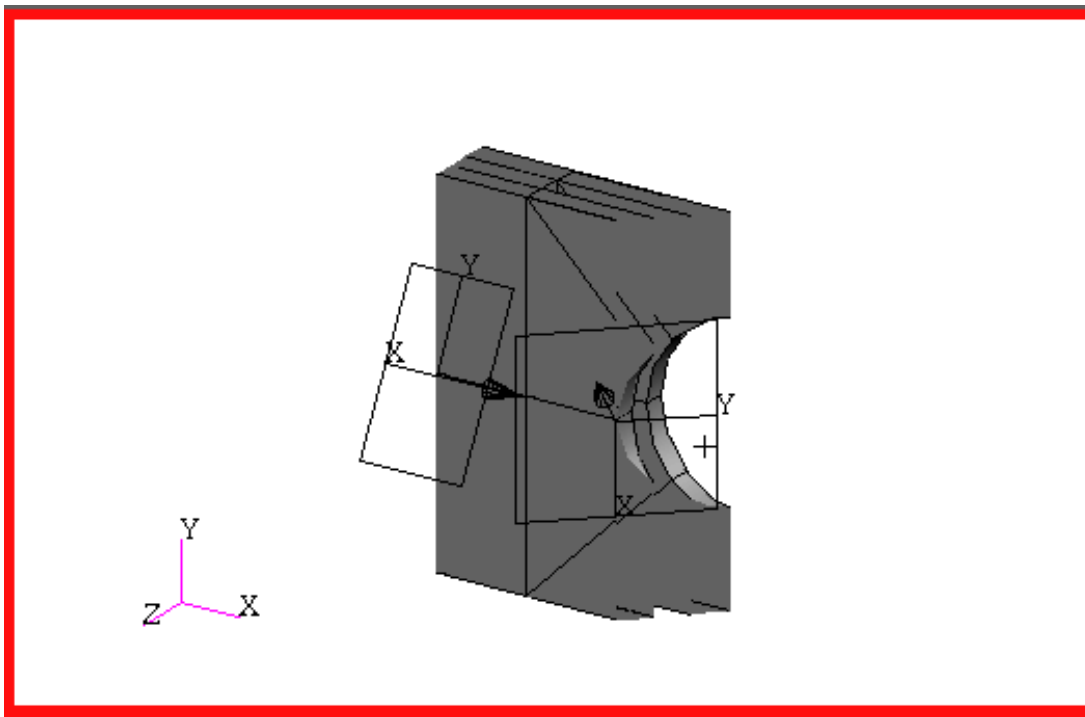

9. Return to the top view and then change **clip_2** so that it no longer moves with the model. Notice the effect this has on the model.

Using the *Main Form* icon, change to a **Top view** of the model.



Target Clipping Plane:

clip_2

Clipping Plane Attributes

Move With Model

Apply

With the **Move with Model** option set to off, clipping plane's direction is defined with respect to the screen coordinate axis and not the model axis (default). Change to **Iso 1 View** to observe the effects of the two clipping planes.

10. Change the orientation of **clip_1** using the icons on the form.

Target the **clip_1** clipping plane and practice changing its direction by using the rotation icons located at the center of the form.

11. Unpost the clipping planes and return the model to the isometric view and wireframe render style.

Turn off **clip_1** and **clip_2** by unhighlighting their names in the *Post/Unpost Clipping Planes* listbox (Hint: use the control key) and clicking on the **Apply** button. Click on the **Cancel** button to close the form.

Return the model to **Wireframe** render style before you close the database.

File/Quit...

