

Exercise 6

Element Property Definition for the Space Satellite

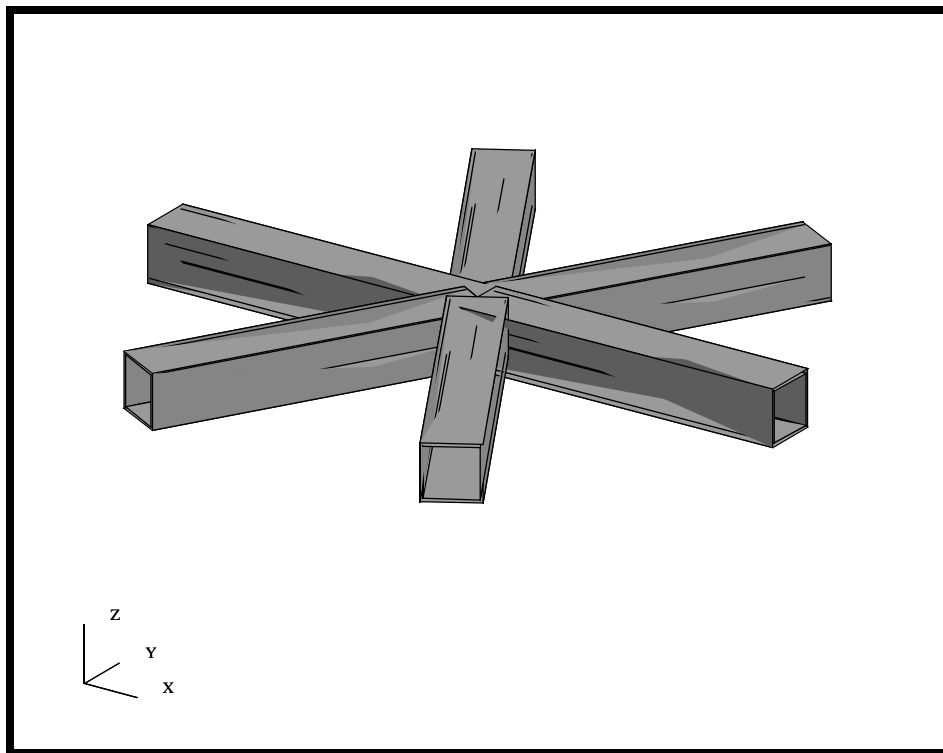

Objectives:

- Define shell, bar, and point mass element properties for the Space Satellite.
- Create and apply a **Field** to describe a spatially varying thickness for the Adapter Cone.
- Verify Mass Properties for the structure.



Model Description:

In this exercise, you will create Element Properties for the Space Satellite. These Properties will include properties for 2-D shell elements, 1-D bars, and 0-D concentrated masses. Additionally, we will be creating a field to define a thickness variation in the Adapter Cone. The thickness of the cone will be 0.05 at its base and will vary linearly to a thickness of 0.10 at its top dimension.

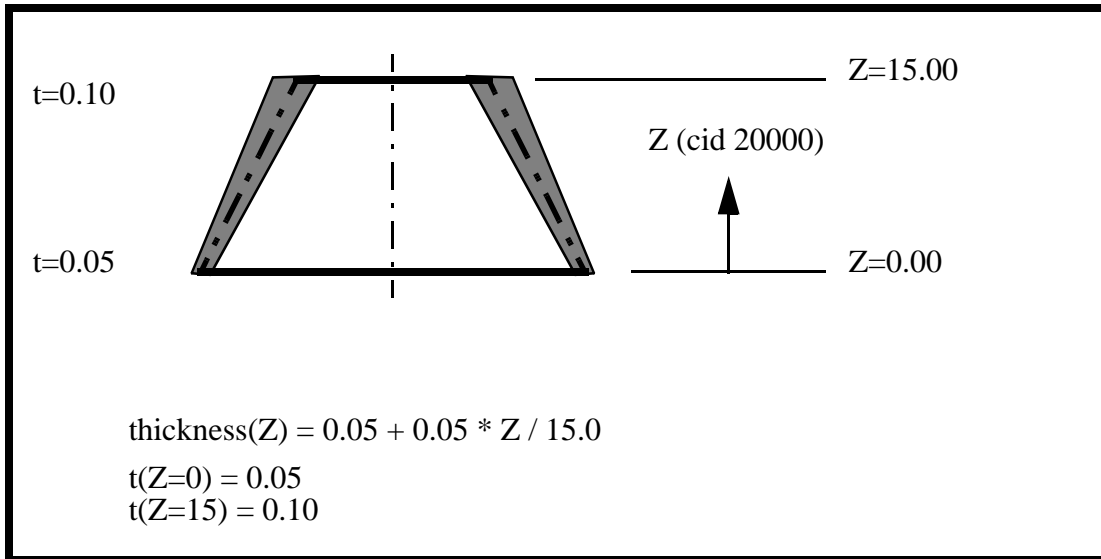
Figure 6.1. Adapter Cone's specifications - 2D slice

We will also be controlling the Property ID's. From within MSC.Patran, you can define the ID of an Element Property or Material by defining a trailing number. If this number is not already defined for another property or material that number will be used. The Property assignments are listed in the table below.

PID #	Component	Type	Units
10000	Central Cylinder	2D Shell	0.250 in
20000	Adapter	2D Shell	field
30000	Upper Platform	2D Shell	0.100 in
39000	Navigational Platform	0D Mass	40 lbs

39100	Navigational Platform Support	1D Bar	Hollow Box 2" x 2" t=0.1 in
40000	Lower Platform	2D Shell	0.350 in
49000	Propulsion Block	0D Mass	60 lbs
50000	Shear Panels	2D	0.125 in
59000	Science Platforms	0D Mass	20 lbs

Suggested Exercise Steps:

- Start MSC.Patran and open the **satellite.db** file.
- Use a PCL Function to define a spatially varying field named **Thickness_variation**, using the equation described in Figure 5.1. Also make sure the definition is based on CID 20000.
- Post and define each of the 2D Shell Element Properties that are listed in the table above.
- Post and define each of the 1D Beam element properties that are listed in the table above.
- Post and define each of the 0D Mass element properties that are listed in the table above.
- Display the Mass property and compare with the Mass hand calculation.
- Close and Exit MSC.Patran.

Exercise Procedure:

*Note: In most MSC.Patran forms, the default setting for the **Auto Execute** button is on; thus, you do not need to press **Apply**.*

1. Start MSC.Patran and open the **satellite.db** file.

File/Open...

Existing Database Name	satellite.db
OK	

2. Before we get started, let's define a common render style and view using the Toolbar icons.



Isometric View 3



Wireframe

3. Create a spatially varying scalar field named **thickness_variation** that will later be used to define the Adapter Cone's thickness. Use the scalar field described in Figure 6.1.

Fields to Define a Spatially Varying Load

◆ Fields

Action:	Create
Object:	Spatial
Method:	PCL Function
Field Name	thickness_variation
Field Type	◆ Scalar
Coordinate System Type	◆ Real
Coordinate System	Coord 20000
Scalar Function	0.05+0.05*'Z/15.0

Note: Remember to precede the independent variable, capital Z, with a single quote.

Apply

4. Lets verify the thickness variation we just defined.

Action:

Show

Select Field to Show

thickness_variation

Specify Range...

Minimum

0.0

Maximum

15.0

Number of Points

11

OK

Apply

You will now get an XY Plot of the data as well as a Table defining the evaluated values. The XY Plot should look like the figure below.

Figure 6.2. Spatial Field Variation

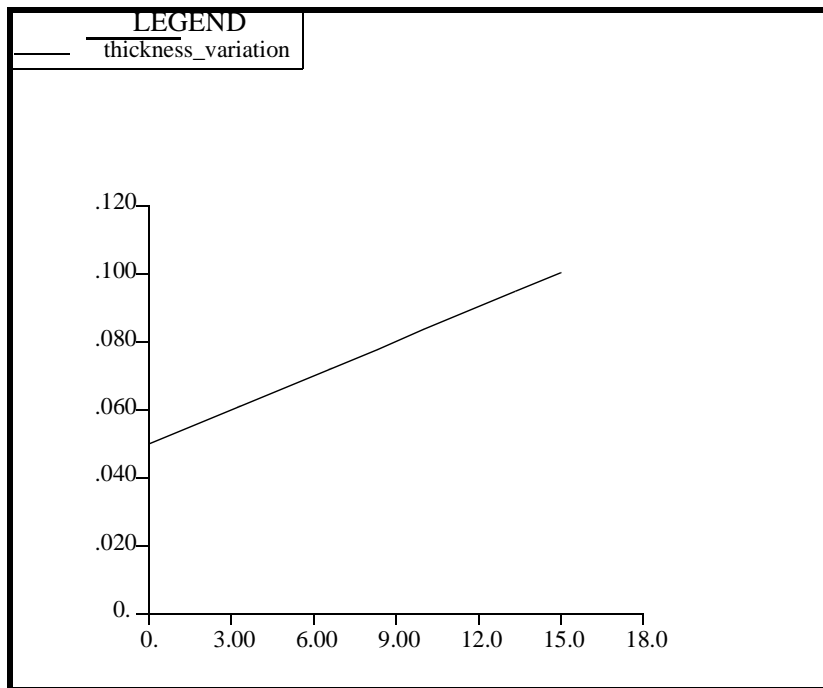

To unpost the XY Window, select the following button on the Fields Form.

Unpost Current XY Window

Plotted Curves window

Cancel

- In this section, we will create properties for all 2D Shell elements. To do this, we will post each group, then define the appropriate element properties. The 2D Shell element properties are given in the table below. It should also be noted, by ending the name with an ID, that ID will be used when the model is written out.

Defining Shell Elements

Property Name	Material	Thickness
Central Cylinder.10000	Aluminum	0.250 in
Adapter.20000	Titanium	field
Upper Platform.30000	Aluminum	0.100 in
Lower Platform.40000	Aluminum	0.350 in
Shear Panels.50000	Aluminum	0.125 in

Let's start by posting the Central Cylinder group.

Group/Post...

Select Groups to Post

- Adapter
- All Fem
- All Geometry
- Central Cylinder**
- Lower Platform
- Navigational Platform
- Propulsion Block
- Science Platforms
- Shear Panels
- Upper Platform
- default_group

Apply

Cancel

Now, let's define the element property for the Central Cylinder. The Central Cylinder will have an ID of 10,000, thus the name Central Cylinder.10000. Additionally, it is made of aluminum and a 0.25 inches thick.

◆ **Properties**

Action:	<input type="text" value="Create"/>
Dimension:	<input type="text" value="2D"/>
Type:	<input type="text" value="Shell"/>
Property Set Name	<input type="text" value="Central Cylinder.10000"/>

In the *Input Properties...* form, click in the *Material Name* data box. The material properties available for selection will appear in the Material Property Sets list.

Click on **aluminum** under the *Material Property Sets* box. The selected material name will appear with the prefix "m:" in the *Material Name* data box.

Material Name	<input type="text" value="m:aluminum"/>
Thickness	<input type="text" value="0.250"/>

Select Members	<input type="text" value="Select all posted surfaces"/>
----------------	---

Repeat this process, posting the group then assigning the element properties, for the Upper Platform, Lower Platform and Shear Panels. DO NOT define a Property for the Adapter at this time. Note the use of the property numbering encoded syntax.

- Now, we will define the element properties for the Adapter. The Adapter has a variable thickness. We will use the previously create field, Thickness_variation, to define this variation.

Let's start by posting the Adapter group.

Group/Post...

Applying a Spatially Varying Thickness

Select Groups to Post

Adapter
All Fem
All Geometry
Central Cylinder
Lower Platform
Navigational Platform
Propulsion Block
Science Platforms
Shear Panels
Upper Platform
default_group

Apply

Cancel

Now, let's define the element property for the Adapter. The Adapter will have an ID of 20,000, thus the name Adapter.20000. Additionally, it is made of titanium and we will use a field to define its thickness.

Action:

Create

Dimension:

2D

Type:

Shell

Property Set Name

Adapter.20000

Input Properties...

In the *Input Properties...* form, click in the *Material Name* data box. The material properties available for selection will appear in the Material Property Sets list.

Click on **titanium** under the *Material Property Sets* box. The selected material name will appear with the prefix "m:" in the *Material Name* data box.

Material Name

m:titanium

In a similar method we used to define the material, we will define the thickness field for the Adapter. Click in the *Thickness* data box. The fields available for selection will appear in the Field Definitions list.

Select the `thickness_variation` field from the list. The selected material name will appear with the prefix “f:” in the *Thickness* data box indicating a spatial varying field has been applied.

Thickness

f:thickness_variation 

OK

Select Members

Select all posted
surfaces 

Add

Apply

7. Verify the thickness variation on the Adapter Cone.

We will now use the Properties Show utilities to verify the spatially varying thickness of the Adapter Cone.

Verify the Spatially Varying Thickness

Action:

Show

Existing Properties

Material Name
Property Set Name
Thickness

Display Method

Scalar Plot

Select Groups

Adapter

Apply

This will create a element fill plot of the Adapter Cone thickness. You will notice each element is uniform. Your model should look like the figure below.

Figure 6.3. Thickness Variation as Applied to the Adapter Cone.

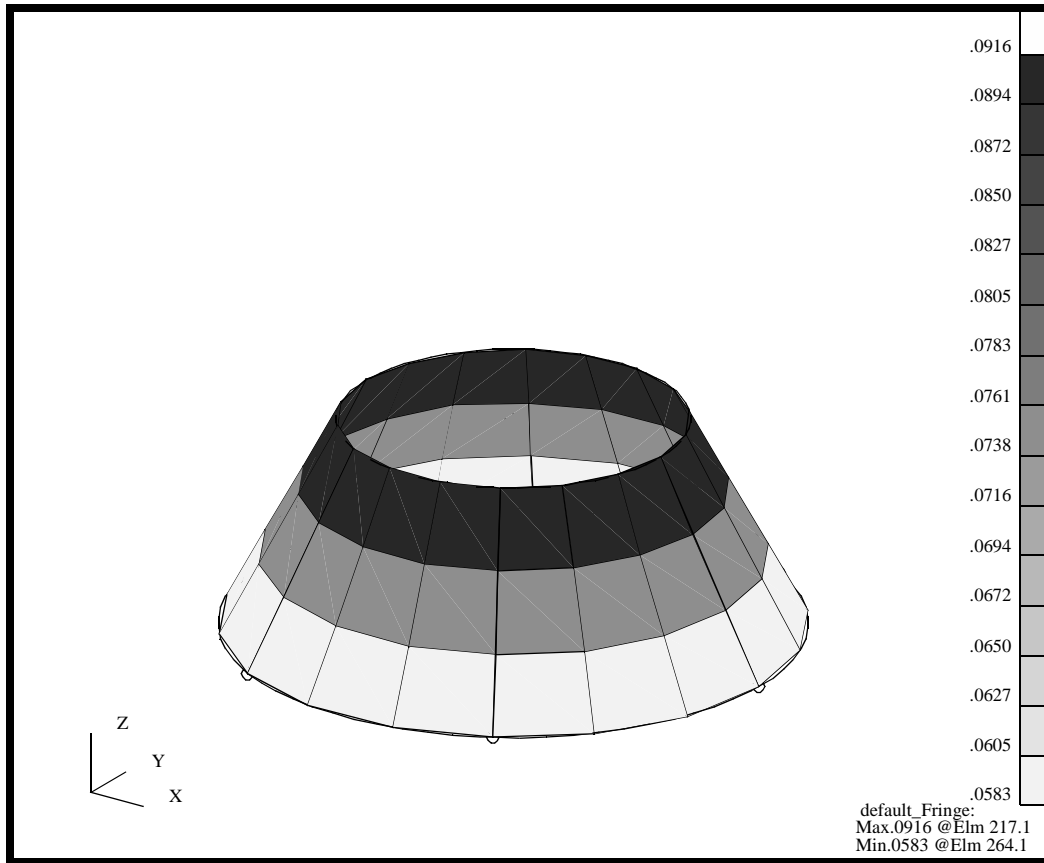

Property show is a good tool to verify various property assignments, including, bar XY plane definition, material assignment, field assignment, etc. All of the verification checks can be displayed in a number of graphical as well as tabular forms. Before we proceed, let's clear the plot by using reset graphics from the Main Form.



Reset graphics

8. Create the Bar properties for the Navigational Platform. We will use a PBARL type MSC.Nastran element property and define a box section that is 2 x 2 with a thickness of 0.10. Also, the navigational platform will have a PID of 39100.

**Create 1-D
Bar
Properties**

Let's first post the Navigational Platform.

Group/Post...

Select Groups to Post

- Adapter
- All Fem
- All Geometry
- Central Cylinder
- Lower Platform
- Navigational Platform**
- Propulsion Block
- Science Platforms
- Shear Panels
- Upper Platform
- default_group

Apply

Cancel

Now lets define the element property for the Navigational Platform support structure. The structure is modeled with 1-D beams which have a 2x2 box cross section and a wall thickness of 0.1 inches.

◆ **Properties**

<i>Action:</i>	Create
<i>Object:</i>	1D
<i>Type:</i>	Beam
<i>Property Set Name</i>	np_support.39100
<i>Options</i>	General Section
	Standard Formulation

Input Properties...

In the *Input Properties...* form, click in the *Material Name* data box. The material properties available for selection will appear in the Material Property Sets list.

Click on **aluminum** under the *Material Property Sets* box. The selected material name will appear with the prefix “**m:**” in the *Material Name* data box.

<i>Material Name</i>	m:aluminum 
----------------------	---

Now change the options menu on the right side of the Section Name window from Properties to dimensions. This will tell MSC.Patran we are defining a MSC.Nastran Section using section Properties by dimensions, intern, this will write out a PBARL card.

[Section Name]

You will get the following message:

The “Associate Beam Section” toggle is currently off. Changing the “Value Type” to “Dimensions” will force the toggle on, recompute and overwrite the current databox properties. Do you want to continue and change the “Value Type” to “Dimensions” ?

Message

Finally, we will define the Bar orientation, which is in +Z direction

Bar Orientation

We will now define a box beam section using the beam’s dimensions. Select the following Icon to open the Beam Library.



Define a standard hollow box section using one of the standard shapes.

Action:

Type:

Method:

New Section Name:

Now select the following icon from the list of beam sections to define a hollow box section.



Hollow Box Section

Define the dimensions for the section, 2 x 2, t=0.1.

<i>W</i>	<input type="text" value="2.0"/>
<i>H</i>	<input type="text" value="2.0"/>
<i>t1</i>	<input type="text" value="0.1"/>
<i>t2</i>	<input type="text" value="0.1"/>

Let's use the Calculate/Display functionality to see the section properties and figure.

A Section Display window should have now appeared on the screen showing you the section and the relevant section properties. Once you have reviewed the information, you can close the form and apply the property.

<i>Section Display Window</i>	<input type="button" value="Close"/>
<i>Beam Library</i>	<input type="button" value="OK"/>
<i>Input Properties Window</i>	<input type="button" value="OK"/>

Let's define the Application Region. We want to assign these properties to the bar elements since there is no available geometry. First, click in the Select Members databox, the Select Menu will then be displayed. Select the Beam Element icon from the Select Menu.



**Select Menu:
Beam element**

Finally, select the All beam elements in the Viewport and create the property.

Select Members

Select all displayed beam elements

Add

Apply

- Now, let's turn on the Display for the Beams so we can visually verify the section we have just created.

Before we get started with this step, turn off the coordinate frame display.

Displaying the Beam Sections

Display/Coordinate Frames...

Post/Unpost Coord. Frame(s)

Select Coordinate Frames 20000 and 30000

UnPost

OK

Make the following changes to your viewport using the following Toolbar icons.



Isometric View 3



Smooth Shaded

Finally, let's display the sections using full section display.

Display/Load/BC/Elem. Props...

Beam Display

3D:Full-Span

Apply

Cancel

You may need to select Fit View from the Toolbar to properly see the beam sections.



Fit view

Your viewport should be similar to the figure below.

Figure 6.4. Hollow rectangular sections representing the Navigational Platform mounting structure as displayed in MSC.Patran.

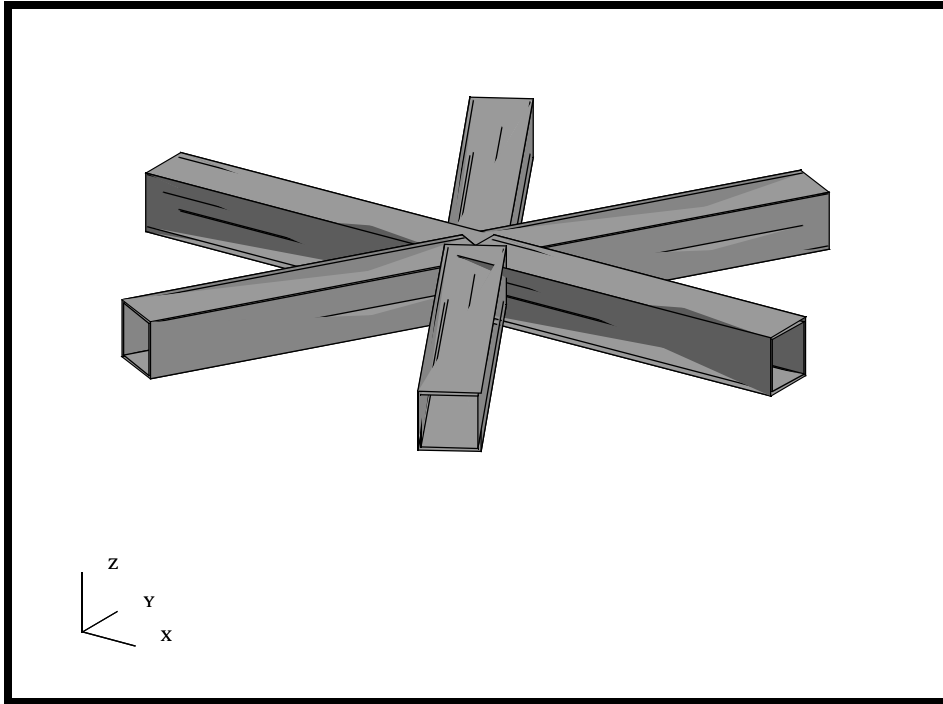

Defining Concentrated Masses

10. We will now turn our attention to defining the last of our properties, the mass elements. These will be defined as 0D element properties.

Again, each of the mass elements have a specific numbering requirements, as follows:

Property Set Name	Component	Type	Mass
np_mass.39000	Navigational Platform	Lumped Mass	40 lbs
pb_mass.49000	Propulsion Block	Lumped Mass	60 lbs
sp_mass.59000	Science Platforms	Lumped Mass	20 lbs

We will start with the Navigational Platform concentrated mass.

<i>Action:</i>	<input type="text" value="Create"/>
<i>Object:</i>	<input type="text" value="0D"/>
<i>Type:</i>	<input type="text" value="Mass"/>
<i>Property Set Name</i>	<input type="text" value="np_mass.39000"/>
<i>Option(s):</i>	<input type="text" value="Lumped"/>
<input type="button" value="Input Properties..."/>	
<i>Mass:</i>	<input type="text" value="40.0"/>
<input type="button" value="OK"/>	

Again, let's define the Application Region. We want to assign these properties to the Point elements. First, click in the Select Members databox, the Select Menu will then be displayed. Select the Point Element icon from the Select Menu.



**Select Menu:
Point element**

Finally, select the All point elements in the Viewport and create the property.

<i>Select Members</i>	<input type="text" value="Select all Posted point elements"/>
<input type="button" value="Add"/>	
<input type="button" value="Apply"/>	

Repeat this procedure for the remaining concentrated masses listed in the table above. Remember to use group/post to post the Propulsion Block and Science Platforms groups before assigning the properties. Also, make sure to select all 12 Science Platform point elements.

**Mass
Property
Calculations**

11. Now that we have completed the last of the property assignments, we will now compute the mass for the entire model and compare it back to hand calculations.

First start by posting the All Fem group.

Group/Post...

Select Groups to Post

Adapter
All Fem
All Geometry
Central Cylinder
Lower Platform
Navigational Platform
Propulsion Block
Science Platforms
Shear Panels
Upper Platform
default_group

Apply

Cancel

Next, reset the model orientation and render style using the following Toolbar icons.



Isometric View 3



Smooth Shaded

Also, close the Mass Properties form by unselecting the Properties toggle from the main form.

◆ Properties

Now, lets compute the mass of the vehicle. Since we defined all the densities and masses in units of weight, the resulting quantities will be in units of lbs.

Tools/Mass Properties...

Action:

Show

Dimension:

3D

Define Region...

*Region:***All***Include:***FEM****OK***Relative to Coordinate Frame***Coord 0***Density/Concentrated Mass***Use Element Properties***Thicknesses/Areas/NSM***Use Element Properties** **Plot Principal Axes at CG** **Create Princ. Coord Frame** Write to Report**Apply**

Upon Apply, a spreadsheet will appear which will include the mass property of the vehicle of 741.1 lbs. You can also look at a variety of other mass property calculations, such as inertia tensors.

Your model should be similar to the display below.
Figure 6.5. Principal Mass Properties Coordinate System for Satellite.

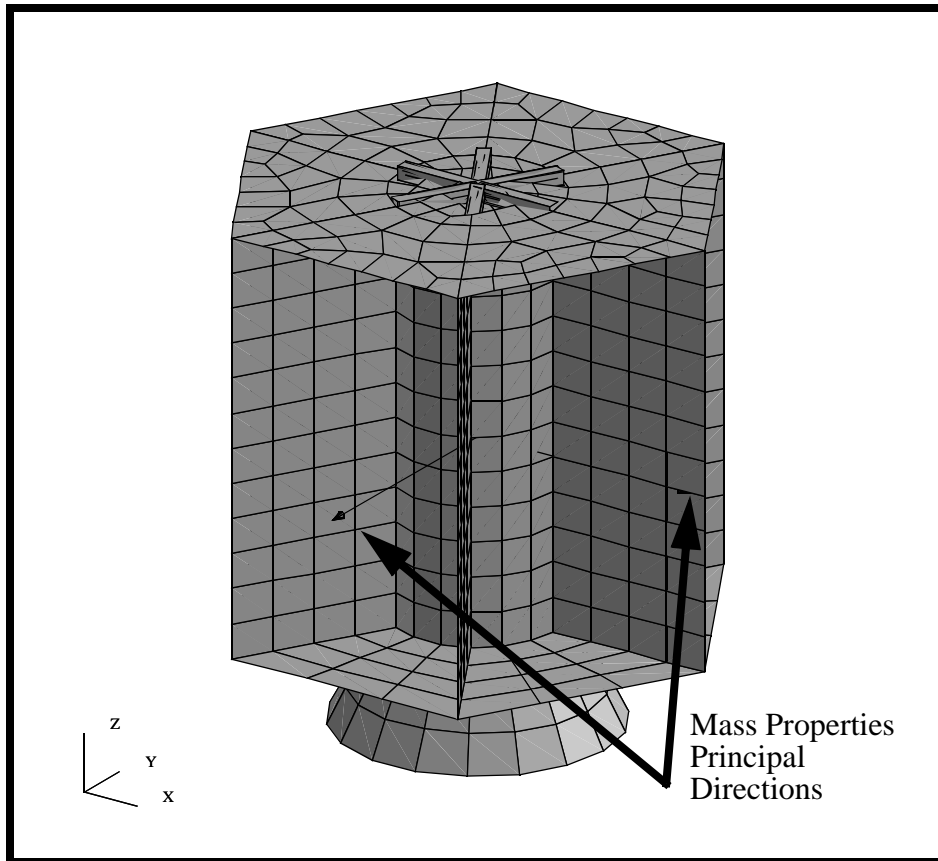

As requested, an additional coordinate system will be automatically generated at the model Center of Gravity and Displayed.

The equivalent hand calculation is given in the table below.

Component	Qty	Calculation	Item Mass
Central Cylinder	1	0.250 in * 6 * 754 in ² * 0.101 lb/in ³	114.23
Adapter	1	0.075 in * 6 * 284.4 in ² * 0.16 lb/in ³	20.48
Upper Platform	1	0.100 in * 3367.1 in ² * 0.101 lb/in ³	34.01

Element Properties for a Space Satellite

Lower Platform	1	0.350 in * 3367.1 in ² * 0.101 lb/in ³	117.85
Shear Panels	6	0.125 in * 1440 in ² * 0.101 lb/in ³	109.8
Science Platforms	12	20 lbs	240 lbs
Navigational Platform	1	40 lbs	45.53 lbs
Propulsion Block	1	60 lbs	60 lbs
TOTAL			741.90 lbs

This hand calculation based on geometric areas is in very good agreement with the MSC.Patran Mass Property calculation of the Satellite FEM model of **741.10 lbs**.

Mass Property Display Window

Cancel

Mass Property Form

Cancel

12. To complete this exercise, you will close the database.

File/Quit

This will exit MSC.Patran and close your file. Do not delete the database from your directory since you will use it for future exercises.

Close the Database and Quit MSC.Patran

