

---

## Exercise 7

# *Static and Normal Mode Analysis of a Space Satellite*

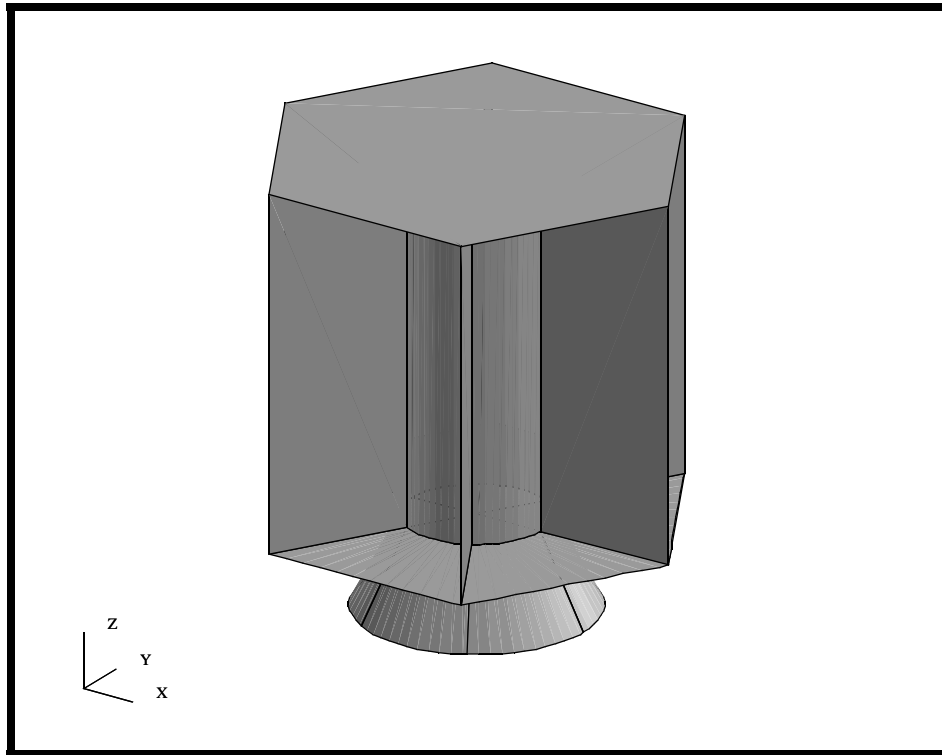

### **Objectives:**

- Setup and analyze the satellite model for a normal modes and static analysis.
- Learn to modify the default subcase parameters, solution parameters, and output requests.



## Model Description:

In this exercise, we will set up and run two analyses for the Space Satellite. One analysis is Linear Static and another is a Normal Modes analysis. MSC.Patran provides a set of default parameters and output requests for each solution. We will additionally define the following MSC.Nastran parameters from MSC.Patran:

```
param, WTMASS  
param, K6ROT  
param, COUPMASS (MODAL ONLY)
```

We will be making additional output requests and defining other solution parameters, such as the number of modes. We will be requesting two different results formats, an OP2 and an XDB. We will be discussing the differences for these in a later exercise. Once the subcases are properly setup and chosen, we will submit the analyses directly from MSC.Patran.

## Suggested Exercise Steps:

- Start MSC.Patran and open the **satellite.db** file.
- Choose a linear static analysis. Define a weight mass conversion of 0.00259 and a rotational plate stiffness of 10.
- Modify the Launch Static subcase to include element forces.
- Select the Launch Static subcase for analysis.
- Submit the Launch Static subcase for analysis and monitor the solution.
- Choose a Normal Modes analysis and define a weight mass conversion of 0.00259, a coupled mass matrix and a rotational plate stiffness of 10.
- Modify the Launch Modal subcase to choose the first 6 modes.
- Select the Launch Modal subcase for analysis.
- Submit the Launch Modal subcase for analysis and monitor the solution.
- Close and Exit MSC.Patran

---

## Exercise Procedure:

1. Start MSC.Patran and open the **satellite.db** file.

### File/Open...

Existing Database Name

**satellite.db**

**OK**

2. We are now ready for analysis. In this step, you will define the analysis solution type and parameters, a linear static analysis. In later steps, we will setup the subcases, write out an input deck and run the analysis. We will be submitting two analyses, a Static and Normal Modes solution.

We will begin by defining the subcase for the static analysis launch condition. For the first analysis, a static launch condition, we will be asking for a text format of an *op2* file. Additionally, we will be defining a plate rotation stiffness and a weight mass conversion that is to be applied to all density, non-structural mass and lumped mass (MSC/NASTRAN K6ROT and WTMASS parameters, respectively)

### ◆ Analysis

Action:

**Analyze**

Object:

**Entire Model**

Method:

**Full Run**

Job Name:

**satellite\_static**

**Translation Parameters...**

Data Output:

**Op2 and Print**

OUTPUT2 Format:

**Text**

**OK**

**Solution Type...**

Solution Type:

◆ **LINEAR STATIC**

**Solution Parameters...**

Plate Rz Stiffness Factor =

**10.0**

Wt.-Mass Conversion =

**0.00259**

**OK**

OK

- Define the subcases for the static launch condition. We will be using the subcase based on the load cases created earlier.

## Create the Static Subcase

In MSC.Nastran, a subcase provides a tool to associate loads and boundary conditions, output requests and various other parameters depending on the solution type selected. These subcases are essential to perform structural and thermal analysis of structures.

MSC.Patran automatically generates one subcase for every Load Case created. For this analysis, we will be using the subcase that was automatically created for the "Launch Static" load case. In addition, each solution type also has an associated "Default Subcase" which corresponds to a default load case.

You can access the subcase information from the **Subcase Create...** button. You will notice the Default, Launch Modal and Launch Static as Available Subcase. These have automatically been created. If you select on any of these subcases, you will notice each subcase corresponds to a load case with the same name. Each automatically generated subcase has a standard set of requested outputs and solution parameters. For a Static analysis, the stress, constraint forces and displacements have already been chosen. These can be inspected by pressing the *Output Requests* button inside the **Subcase Create...** form.

We will additionally request Element Forces and Grid Point Force Balance for the Launch Static analysis.

### Subcase Create...

Available Subcases:

Default
Launch Modal
Launch Static

Subcase Options

Output Requests...
--------------------

Select Result Type

Element Forces
----------------

Select Result Type

Grid Point Force Balance
--------------------------

OK

Apply

Cancel

---

## Static Analysis Setup

4. We will now select the subcases to analyze.

The subcases that will be analyzed are listed in the **Subcase Select...** form. Selected subcases will appear in the *Subcases Selected* list box. To select a subcase, pick any subcase listed in “*Subcases For Solution Sequence: 101*” list box. To de-select a subcase, pick on it from the *Subcases Selected* list box. For this analysis, we will only be analyzing the *Launch Static* load case. Therefore, you will need to de-select the Default subcase and select the Launch Static subcase.

### Subcase Select...

*Subcases For Solution Sequence: 101*

**Launch Static**

(Click on this to select)

*Subcases Selected:*

**Default**

(Click on this to deselect)

**OK**

---

## Submit and Monitor the Analysis

5. Submit and monitor the analysis.

To submit the analysis, just select *Apply* in the main **Analysis** form.

**Apply**

When the job is finished, we will use these results to post-process the analysis.

If you have Analysis Manager installed on the system, you will see a Graphical User Interface (GUI), which shows you how the job is proceeding, errors, CPU and Disk usage. Look for any errors in the *Mon File* window. When the job is finished, simply *Close* the *Analysis Manager Job Graph* window

**Close**

If you do not have Analysis Manager installed, you can monitor the analysis by opening a shell on the same system/directory location. In UNIX, you can type in the following command:

```
tail -l satellite_static.f06
```

This will display any messages normally output to the *F06* file to the shell while the job is running. These messages will also tell you the progress of the job and whether the analysis was successful or not.

# Static and Normal Modes of a Satellite

Regardless of which method you used to submit and monitor the analysis, look for any errors that may have occurred. If you have any errors, ask the instructor for assistance. If the job completes normally, proceed onto the next step to create a modal analysis of the Space Satellite.

- We will now setup and submit a Normal Modes run for the vehicle in the launch (constrained) condition.

We will be creating an analysis deck for capturing the first 6 modes of the Satellite in a launch (constrained) configuration. We will also be requesting the analysis be written to a *XDB* file as opposed to an *op2* file. Additionally, we will be defining a coupled mass matrix formulation, a plate rotation stiffness term, and a weight mass conversion that is to be applied to all density, non-structural mass and lumped mass (MSC/NASTRAN COUPMASS, K6ROT and WTMASS parameters, respectively).

## Setup a Modal Analysis

### ◆ Analysis

Action:

Analyze

Object:

Entire Model

Method:

Full Run

Job Name:

satellite\_modal

Translation Parameters...

Data Output:

XDB and Print

OK

Solution Type...

Solution Type:

◆ NORMAL MODES

Solution Parameters...

Mass Calculation:

Coupled

Plate Rz Stiffness Factor =

10.0

Wt.-Mass Conversion =

0.00259

OK

OK

- 
7. Define the subcases for a Modal analysis of the Satellite in the launch (constrained) condition. We will be using the subcase based on the load cases created earlier. We will also be requesting the first 6 modes of the structure.

**Subcase Create...**

*Available Subcases:*

<b>Default</b>
<b>Launch Modal</b>
<b>Launch Static</b>

*Subcase Options*

<b>Subcase Parameters...</b>
------------------------------

*Number of Desired Roots =*

<b>6</b>
----------

<b>OK</b>
-----------

*Subcase Options*

<b>Output Requests...</b>
---------------------------

*Select Result Type*

<b>Element Strain Energies</b>
--------------------------------

<b>OK</b>
-----------

<b>Apply</b>
--------------

You may get the following message asking if you wish to overwrite the Launch Modal loadcase that was created automatically, if you do, answer Yes.

*Subcase "Launch Modal" already exists. Do you wish to delete the existing subcase and create a new one?*

<b>Yes</b>
------------

Select Cancel to close the form and Subcase Select to select the subcase for analysis. Note, you will need to first de-select the Default Subcase.

<b>Cancel</b>
---------------

**Subcase Select...**

*Subcases Selected:*

<b>Default</b> (Click on this to deselect)
---

*Subcases For Solution  
Sequence: 103*

<b>Launch Modal</b> (Click on this to select)
--

<b>OK</b>
-----------

8. Submit and monitor the analysis.

To submit the analysis, just select Apply in the main.

**Apply**

Monitor the analysis using the same approach presented above. Again, if you have any problems, please ask the instructor.

9. To complete this exercise, you will close the database.

**File/Quit**

This will exit MSC.Patran and close your file. Do not delete the database from your directory since you will use it for future exercises.

---

**Submit and  
Monitor the  
Analysis**

---

**Close the  
Database  
and Quit  
Patran**

