

Exercise 9

Post-Processing Modal Results of a Space Satellite

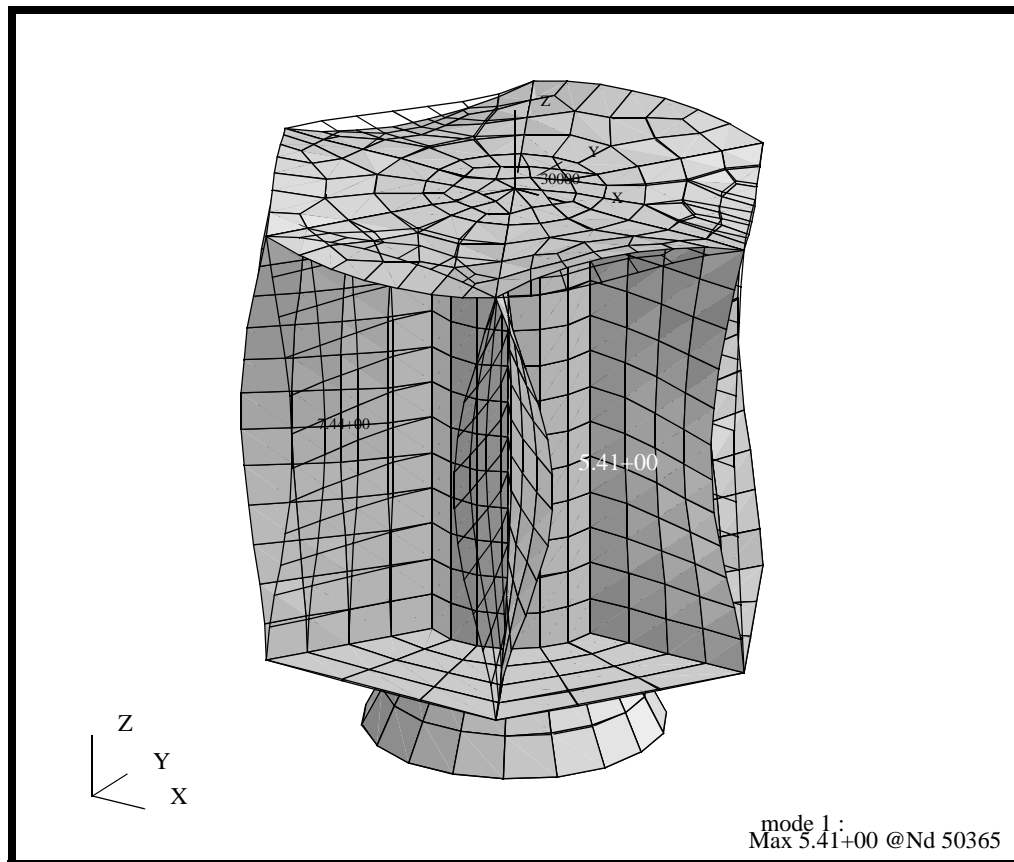

Objectives:

- Post-process model results from an XDB file.
- View and animate the eigenvector displacements of the Satellite for two modes simultaneously.
- Sum the Percentage Element Strain Energy for one component of the Satellite.



Model Description:

In this exercise, you will examine the modal results of the Satellite. You will create mode shape plots of the model for modes 1 and 3. You will then animate modes 1 and 3 acting simultaneously. Also, you will be creating fringe plots of the percentage elemental strain energy for the Upper Platform. Finally, you will use shareware utilities to sum the elemental strain energies of the Upper Platform.

Suggested Exercise Steps:

- Start MSC.Patran and create a new database `modal_results.db`.
- Change the *Tolerance to Default* and the *Analysis Code* to **MSC/NASTRAN**.
- Import the Satellite database using **File/Import...** MSC.Patran DB and select the `satellite.db`.
- Use the Analysis Form to Attach the modal XDB file you created in the previous exercise, `satellite_modal.xdb`.
- Post only the All Fem group, reset the graphics and reorient the model to Isometric view 3.
- Create a deformed plot for Eigenvector 1. Under Deformation Results, modify the Display Attributes and Plot Options to change the display. Make the following changes under Display Attributes: Render Style = Shaded, turn Undeformed model off. Make the following changes under Plot Options: Save Deformation Plot As = mode 1.
- Repeat the above procedure, but this time use mode 3. Make the following changes in Display Attributes: Deformed Color = Red, Render Style = Hidden Line, turn Undeformed model off. Make the following changes under Plot Options: Save Deformation Plot As = mode 3.
- Now create a 3D Animation. Select DEF-mode 1 and change its Animation Method to Modal, then select Update Tool. (DO NOT HIT APPLY YET). Repeat this step for DEF_mode 3. Now hit Apply. With the 3D Graphics set on, you should be able to see both modes animating simultaneously.
- Stop the Animation and Reset the Graphics.
- Group post only the Upper Platform, unpost all other

groups.

- Use the Plot/Erase form (via the Toolbar) to Erase the geometry (leaving only the FEM).
- Now create a fringe plot of the Element Strain Energies, Percentage of Total. Do this for mode 1.
- Now create a summation of the Results using Utilities. Use the following Menu Option: Show/Element/Summation.

From Select Result... select mode1 result Case and Strain Energy, Percentage as the Result Type - Close.

From Options... change the element Nodal Results to the Centroid - Save/Cancel

Now change the Location In Element to Centroid and Select all posted elements. Finally select all posted elements and hit apply.

Repeat this step but for the group All Fem. Your spread sheet should indicate about 100%.

- Finally, Close and quit MSC.Patran.

Exercise Procedure:

1. Open a new database and name it `modal_results.db`.

Open a New Database

In this exercise, we will open a new database and import the model database into this database. We will then “attach” the MSC.Nastran XDB results file to this database. Alternatively, we could have opened the `satellite.db` and “attached” the results into that database. Since we have chosen to separate the static from the modal results, we have made a conscious decision to separate the model data from the results as well as separate the results solutions.

File/New...

New Database Name

New Model Preference

Tolerance Default

Analysis Code:

2. Import the satellite database created in the previous Satellite exercise.

Import the Satellite Database

This step will import the model data from the original satellite database. All pre-processing information, such as Geometry, FEM, Loads & Boundary conditions, Materials, Element Properties and Groups will be imported into this database. We could use the MSC.Patran Options to limit the content of what is brought into the new database. For this exercise, we will use the default and import all Entities into this database.

File/Import...

Object:

Source:

Import File

Note: this can be selected from the PATRAN Databases list

Apply

Once the import is completed, you will get a summary window listing all the MSC.Patran entities imported into the new database.

PATRAN Database Import
Summary window

OK

**Access the
XDB results
data**

3. We will now access the modal results file.

When the MSC.Nastran input file was created for the modal solution, a MSC.Nastran XDB file was requested. With the results in this format, MSC.Patran does not import these results into the database, but instead, it accesses the file generated by MSC.Nastran. Only some basic results header information (types of results, location of the XDB file, etc.) gets stored in the MSC.Patran database. This saves time and disk space since the results are not duplicated inside MSC.Patran. Now “attach” the MSC.Nastran XDB file, **satellite_modal.xdb**.

◆ **Analysis**

Action:

Attach XDB

Object:

Results Entities

Method:

Local

Select Results File...

Selected Results File

satellite_modal.xdb ▼

Note: this can be selected from the Available Files list

OK

Apply

- We will post the group All-Fem, change the view to Isometric View #3 and the render style to Smooth shaded using the Toolbar icon.

Post the All Fem group using Group Post

Group/Post...

Select Groups to Post

Adapter
All Fem
All Geometry
Central Cylinder
Lower Platform
Navigational Platform
Propulsion Block
Science Platforms
Shear Panels
Upper Platform
default_group

Apply

Cancel

From the Main Form, use the Reset Graphics to clear the display.



Reset graphics

Next, reset the render style and view using the Toolbar Icons.



Isometric View 3



Smooth Shaded

Your model should look like the figure below.
Figure 9.1. Imported Satellite Model ready for post processing.

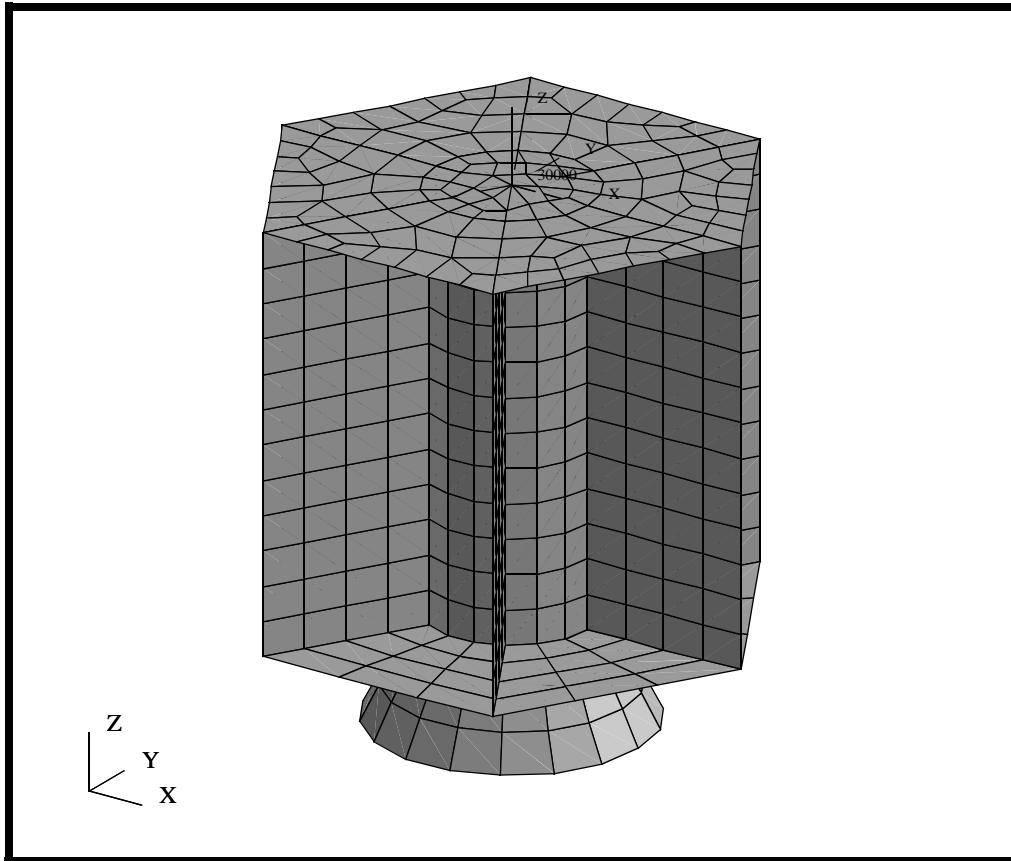

Create a Deformation Plot of Mode 1

5. Create a deformed shape plot of the **Eigenvector** result for mode 1.

We will now use results to make a deformed plot of the first fundamental mode for the Space Satellite. We will use the default plot options.

◆ Results

Action:

Object:

Select Result Case(s)

Select Deformation Result

Apply

Create
Deformation
SC1:LAUNCH MODAL, A1: Mode 1: Freq =
Eigenvectors, Translational

Your model should look like the one shown below

Figure 9.2. Default Eigenvector Deformation Plot

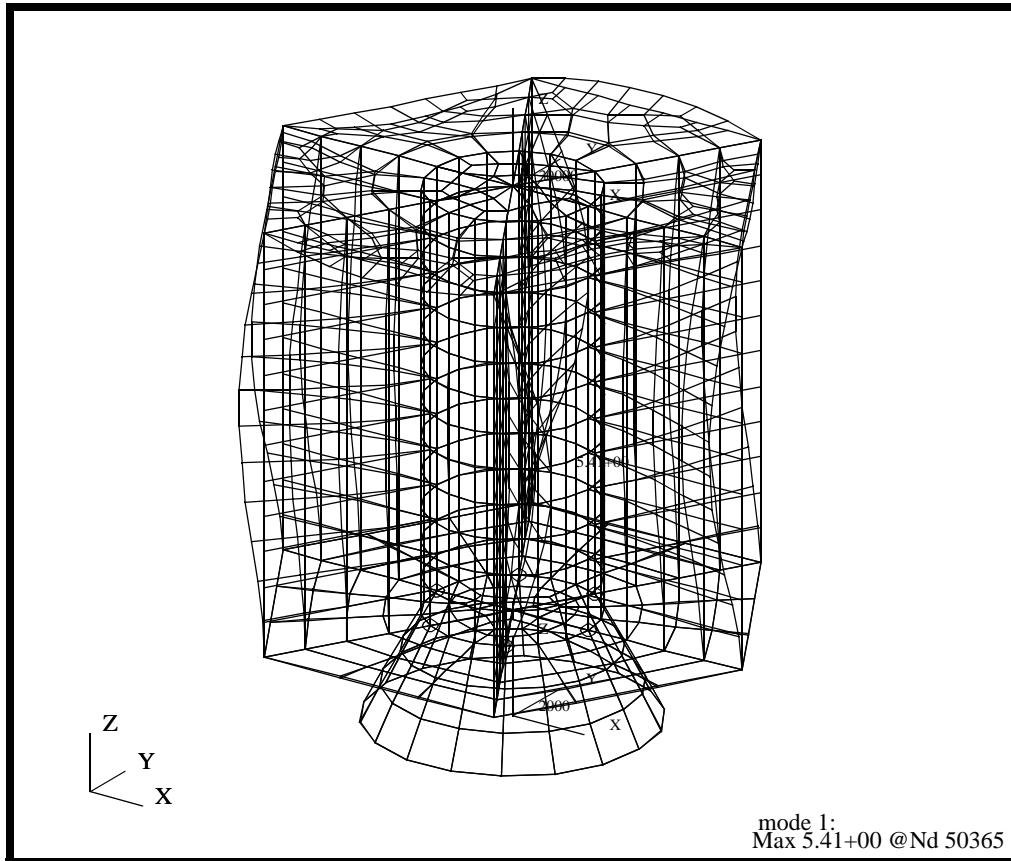

6. Redo the plot of mode 1 with the undeformed model off and the render style set to shaded.

By default, the deformed and undeformed plots are superimposed. The deformed model is in white and the undeformed model is blue. Also, the deformed render style is set to Wireframe. Note, the maximum deformation is indicated in the lower right hand corner of the viewport as well as on the model.

Near the top of every result form is a set of Icons which are used to control the results display. The icons and forms they control will change depending on which type of result tool. These icons control the results selection, entities the results are to be applied on (target entities), results display specific to the type of result tool and animation setup.

**Recreate a
Deformation
Plot of
Mode 1**

From the Main Form, use the Reset Graphics to clear the display.



Reset graphics

The Display Attributes icon controls the appearance, scale factor and graphic options of any deformed plots created using the Deformation tool. Turn off the undeformed plot, change the render style to Shaded.



Display Attributes

Render Style:

Shaded

Show Undeformed

Finally, give the plot a name using the Plot Options



Plot Options

Save Deformation Plot As:

mode 1

Apply

By naming the plot, we can later post and unpost this plot using the results Action Post as well as superimpose other deformed plots (of different names) on top of this plot.

Your model should now look like the figure below. You will notice by turning off the undeformed entities and turning on the Shaded render style, the deformed plot becomes easier to visualize.

Figure 9.3. Eigenvector Deformation for Mode 1 in Shaded Render style.

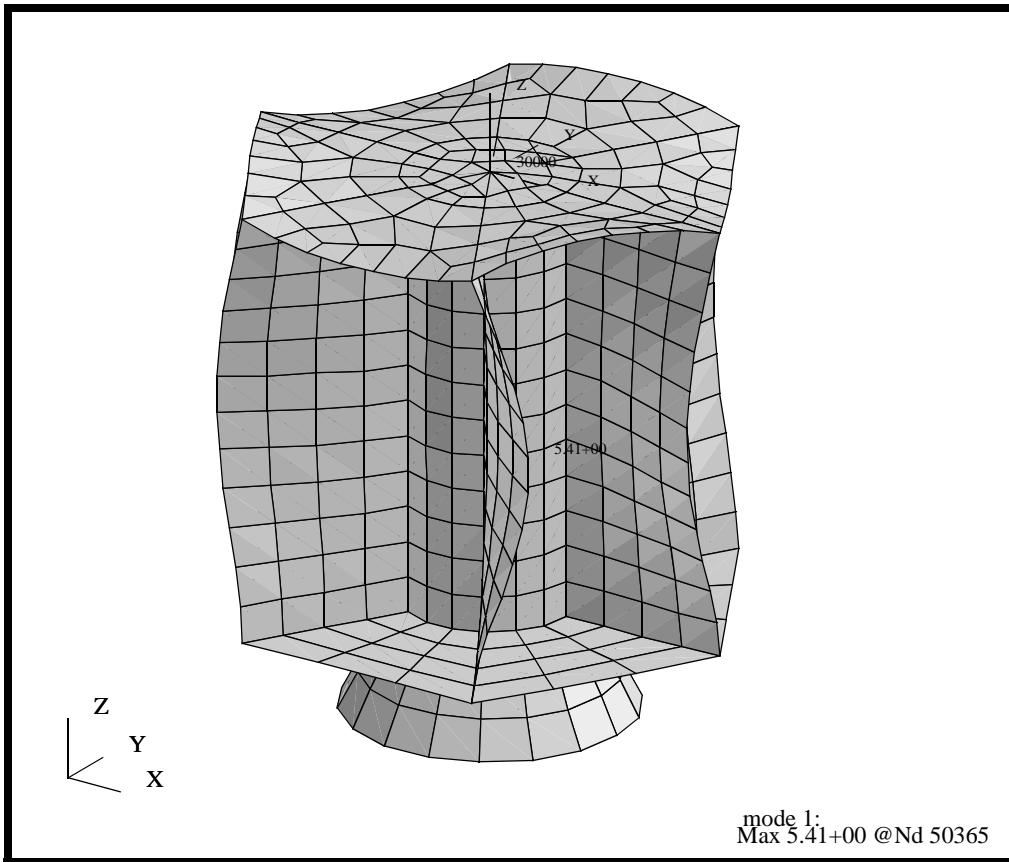

7. Create a deformation plot of the third mode.

We will create a second deformation plot of Mode 3.

**Create a
Deformation
Plot of
Mode 3**



Select Results

Start by selecting the third mode from the Result Cases.

Select Result Case(s)

**SC1:LAUNCH MODAL, A1:
Mode 3: Freq =**

Select Deformation Result

Eigenvectors, Translational

Change the Display Attributes so that the Deformation Color is set to Yellow, the Render Style is set to Hidden Line and the Undeformed model is turned off.

Deformed:

Yellow

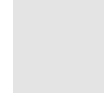

Render Style:

Hidden Line

Show Undeformed

Finally, give the third mode a name using the Plot Options



Plot Options

Save Deformation Plot As:

mode 3

Apply

Your model should look like the figure below. You will notice the second plot was superimposed on top of the first mode. This because we created to deformations with unique names, mode 1 and mode3.

You can choose to post only one plot by using the Results/Post functionality. For this exercise, we will want both deformations posted since we will be creating an animation of both modes in the next steps.

Figure 9.4. Simultaneous Display of the Eigenvector for Modes 1 & 3.

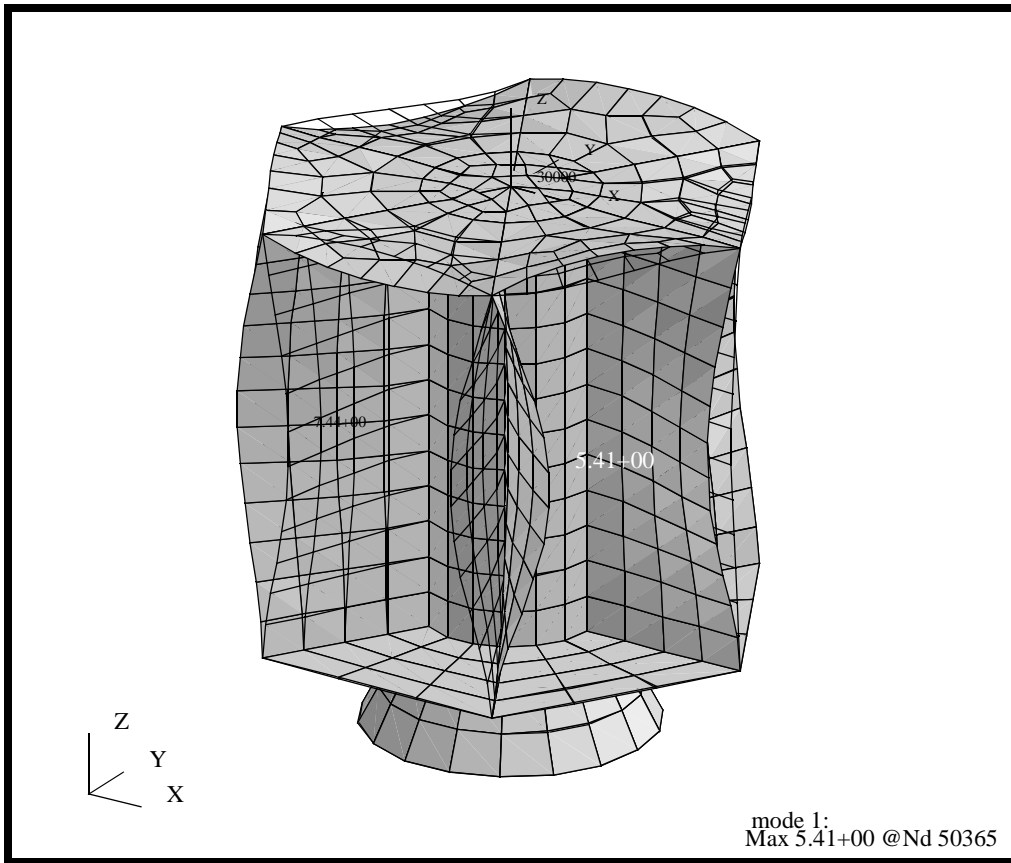

8. Animate modes 1 and 3 simultaneously.

We will use the Animation tool to create a simultaneous animation of the eigenvectors deformations for modes 1 and 3 just created.

Create an Animation of Modes 1 & 3

Action:

Create

Object:

Animation

Method:

3D Graphics

Plots to Animate

None-DEF_mode 1

None-DEF_mode 3

Animation Method:

Modal

Angle Offset:

0.0

Update Tool

Plots to Animate

Modal-DEF_model1

None-DEF_mode 3

Animation Method:

Modal

Angle Offset:

0.0

Update Tool

The model is now ready for animation. You will notice that each of the Plots to animate are now prefixed by the word “Modal”, indicating they have been setup for a Modal type animation. A modal animation is an animation sequence which varies the results values (eigenvectors) from +Max to -Max values. Prior to animation, set the number of frames to 10.

Number of Frames:

10

Interpolation:

Linear

Apply

MSC.Patran will now build the frames and start the animation. The *Animation Control* form will then be displayed. Once the model is animating, you can use the middle mouse button to rotate the model (only available when Animation Graphics is set to 3D). When you are finished, you can use the Stop Animation button on the Animation Control form to stop the animation.

Stop Animation

**Post the
Upper
Platform
Group**

9. We will post the Upper Platform group, change the view to Front View and the render style to Wireframe using the Toolbar.

Post the Upper Platform group using Group Post

Group/Post...

Select Groups to Post

- Adapter
- All Fem
- All Geometry
- Central Cylinder
- Lower Platform
- Navigational Platform
- Propulsion Block
- Science Platforms
- Shear Panels
- Upper Platform**
- default_group

Apply

Cancel

Use the Plot/Erase form from the toolbar to Erase All Geometry.



**Plot/Erase form
(Display Menu)**

Erase All Geometry

OK

Next, from the Main Form, reset the Graphics and change the view using the Toolbar Icons.



Reset graphics



Front view

Finally, your model should look like the figure below

Figure 9.5. Finite elements representing the Upper Platform

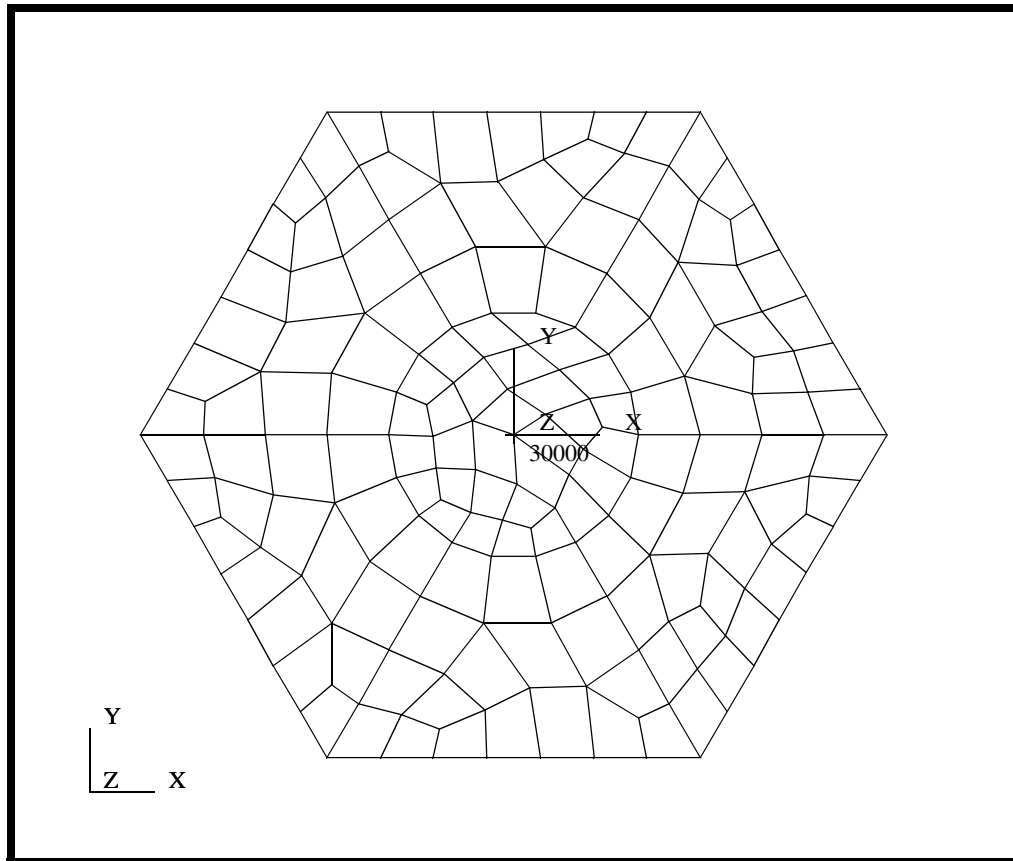

Create a Fringe Plot of the Element Strain Energies

10. Create a fringe plot of the Element Strain Energies, Percentage of Total for mode 1 for the Upper Platform.

We will now plot the elemental strain energies percentage contribution for the Upper Platform.

Action:

Create

Object:

Fringe

Select Result Case(s)

**SC1:LAUNCH MODAL, A1:
Mode 1: Freq =**

Select Fringe Result

**Strain Energy, Percentage of
Total**

We will be using the default Target entities (all elements posted to the viewport). Lets modify the default display settings of the Fringe plot..



Display Attributes

Style:

Shading:

Fringe Edges **Black** 

Display:

Finally, give the plot a name using the Plot Options and define the averaging domain to be none.



Plot Options

Averaging Definition, Domain:

Save Fringe Plot As:

This will create a fringe plot of the percentage of element strain energies for the Upper Platform. You will note that the fringe only produces one color (value) per element (also known as an element fill type plot). This is because the result quantity, elemental strain energy, reports only one value per element at the centroid. Since we choose an averaging domain of None, the centroid value gets extrapolated across the element as a constant resulting in a fill style plot. Your plot should look like the figure below.

Figure 9.6. Element Strain Energy plot of the Upper Platform.

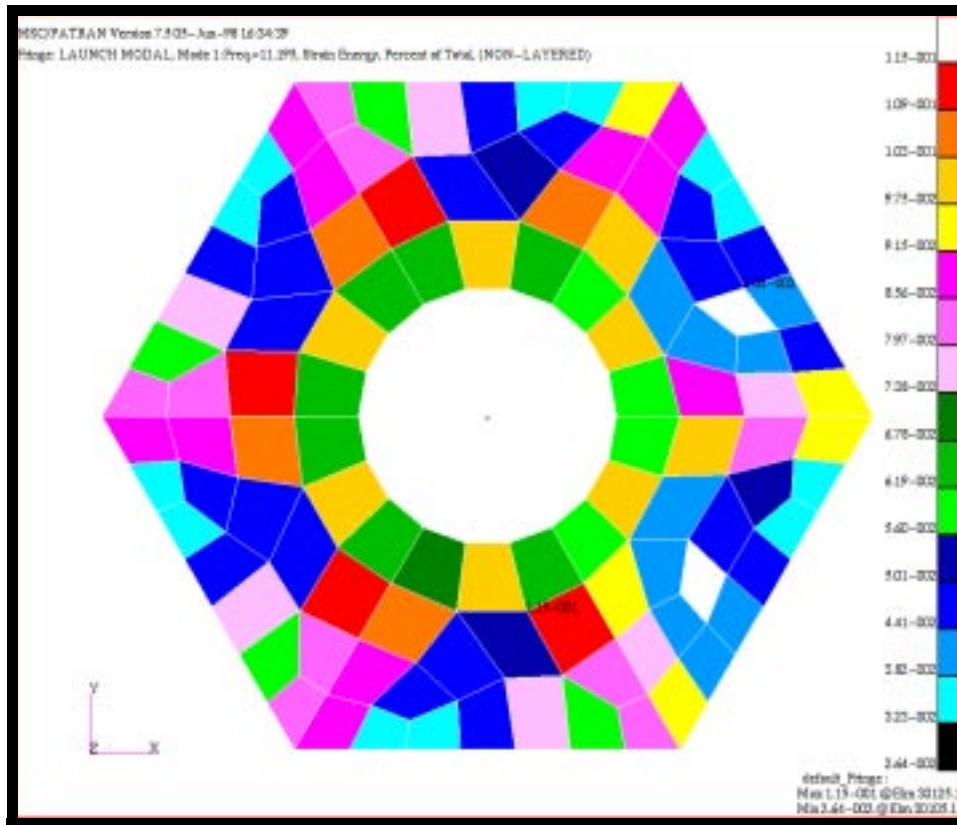

**Sum the
Element
Strain
Energies for
the Upper
Platform**

11. Find out the total contribution of element strain energies by summing the results values using the Shareware Utilities.

We will now compute the element strain energy for the entire Upper Platform as a percentage relative to the entire structure. To do this, we will be using the Shareware Utilities. Shareware Utilities add additional functionality to MSC.Patran and were often requested by and written for customers. These utilities are listed as shareware since they have not gone thru the formal development process and standard QA cycle. However, the utilities have been field tested and updated on an as needed (requested) basis.

NOTE: In order to perform this step it will be necessary to have utilities installed on your system. To verify utilities are available, you should see a “Utilities” menu to the right of Insight Control. If you do not see this menu Option, please contact your Patran or System administrator or class instructor.

**Utilities/Results->
Results Utilities...**

Action:

Show

<i>Object:</i>	<input type="text" value="Elements"/>
<i>Method:</i>	<input type="text" value="Summation"/>
<input type="text" value="Select Results..."/>	
<i>Select Result Cases</i>	<input type="text" value="SC1:LAUNCH MODAL, A1: Mode 1: Freq ="/>
<i>Select Result Type</i>	<input type="text" value="Strain Energy, Percentage of Total"/>
<input type="text" value="Close"/>	
<i>Location In Element</i>	<input type="text" value="Centroid"/>
<i>Show Options</i>	<input type="checkbox"/> Spreadsheet
<i>Selected Elements:</i>	<input type="text" value="Select all posted elements"/>
<input type="text" value="Apply"/>	

Upon Apply, a spreadsheet will appear and list the percentage contribution the Upper Platform's element strain energies contributes to the entire vehicle.

- We will repeat this process, but this time we will compute the Percentage of Strain Energy for the entire vehicle. This should sum to nearly 100%.

To verify the vehicle's element strain energy sums to 100 Percent, simply edit the Selected Elements box with the following syntax; "Element 1T#". This tells MSC.Patran to use elements 1 Thru the highest ID, #, thus all elements.

<i>Selected Elements:</i>	<input type="text" value="Element 1T#"/>
<input type="text" value="Apply"/>	

You should now see an additional row added to the spreadsheet that should indicate a value nearly 100%.

- To complete this exercise, you will close the database.

File/Quit

This will exit MSC.Patran and close your file.

Sum the Element Strain Energies for the Entire Satellite

Close the Database and Quit MSC.Patran

