

Exercise 10

Radiation Analysis of a Space Satellite

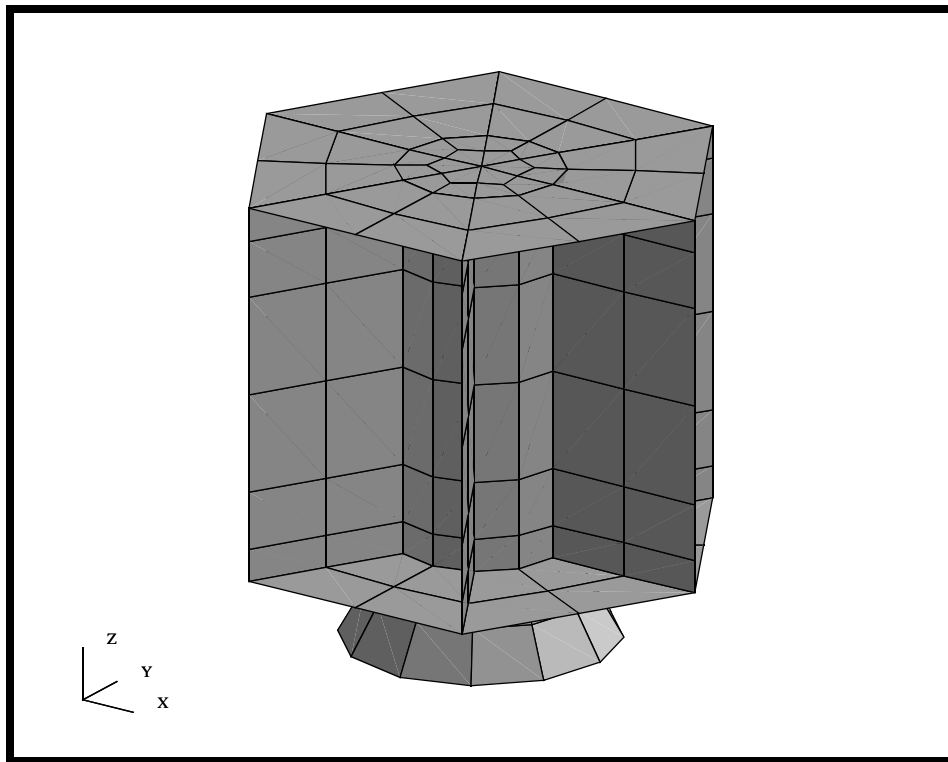

Objectives:

- Build a mesh for a Space Satellite
- Apply Loads and Boundary Conditions.
- Submit Model for Analysis
- Post Process temperature results



Model Description:

In this exercise you will define all the steps to create a radiation analysis for the satellite model using MSC.Patran and using MSC.Nastran to solve the radiation problem. All the geometry for the model is provided via an IGES file. The satellite model is composed of two primary sections, an enclosed cylinder, the Central Core and exposed external surfaces. The Central Core houses the electronics which are used for Guidance, Navigation and Control as well as Communications. The electronic packages provide the heat input for the satellite and are mounted to either end of the Central Core cylinder. Thus, the internal surfaces of the Central Core radiate onto itself (Enclosure Radiation) and conduct heat to any attached surface. All external surfaces are exposed to deep space which will be modeled as radiation to Ambient Space (temperature = 0 degrees Kelvin).

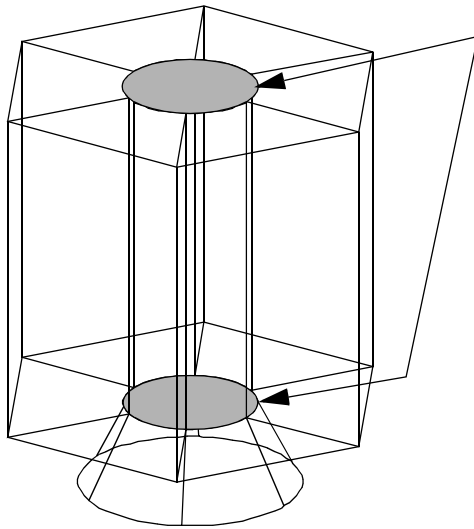

Electronics Mounting Location
Heat Input = 2 watts/in/in

External Emissivity = 0.5
External Absorbivity = 0.5
External Ambient Temperature = 0 deg K

Internal Core Emissivity = 0.9

Material = Aluminum
Thermal Conductivity = 5
Material Thickness = 0.125

Initial Analysis Temperature = 400 deg K
Stephan-Boltzmann constant =
3.6580E-11 WATTS/IN²/K⁴

Upon completion of the analysis, we will use MSC.Patran to post process the temperature distribution for the model. It should be noted, the temperatures are defined in degrees Kelvin. Finally, these results will be used to feed into a structural analysis in another exercise, so do not delete the results file.

Suggested Exercise Steps:

- Start MSC.Patran and open the database **radiation.db**
- Import **radiation.igs** using the IGES Import
- Create two Groups, one called **Central Core** which contains the cylindrical tube and the other group called **External Surfaces**

which contains all remaining surfaces.

- Verify the surface normals for the Central Core group. Verify that the normals are pointing all outward.
- Define a mesh seed for the central core such that it has a nonuniform 2-way bias. Use 6 elements with an L1/L2 ratio of 3.
- Mesh the Central Core surfaces with a mesh density of 8 and the External Surface group with a mesh density of 10. For both models use Quad 8 elements and use the Iso Mesher
- Create a group called All Fem that contains all elements.
- Equivalence the entire model and verify element boundaries.
- Create an Applied Heat loading that is applied to the inside of the Central Core end circular faces. The heat flux should be 2 watts per in².
- Define an enclosure radiation boundary condition for the Central Core. Use an emissivity of 0.9 and define the Bottom (inside) as the application Region. Select all Central Core surfaces.
- Define the radiation boundary conditions for the external faces of the spacecraft that look into deep space (ambient space). Define the ambient temperature of 0 degrees K, emissivity and absorptivity of 0.5. You will need to create three boundary conditions, one for the outside of the core (top surface) and two for the External surfaces (top and bottom surface).
- Create an aluminum material with a thermal conductivity of 5.0
- Create a property for the satellite. We will assume a uniform thickness of 0.125 inches for the entire vehicle.
- Setup and submit a steady state radiation analysis. Define the Initial Temperature of 400 degrees K and a Stephan Boltzmann constant of **3.6580E-11 WATTS/IN2/K4**
- Once the analysis has finished, read in the output2 results file.
- Post process the results and verify the temperature profile. Remember the results are in degrees Kelvin
- Close and Quit MSC.Patran.

Exercise Procedure:

1. Open a new database and name it **radiation.db**.

Open a New Database

File/New...

New Database Name

radiation

OK

New Model Preference

Tolerance

◆ **Default**

Analysis Code

MSC/NASTRAN

Analysis Type

Thermal

OK

2. In this step we will create a group for all geometry. By doing this step first, any new entities will automatically be added to this group.

Group/Create...

New Group Name

All Geometry

Make Current

Unpost All Other Groups

Apply

Cancel

3. All the geometry will be furnished from importing an IGES file.

File/Import...

Object:

Model

Source:

IGES

Import File:

radiation.igs.01

Note: this can be selected from the IGES Files list

Apply

Once the import is completed, you will get a summary window listing what IGES entities was imported into MSC.Patran.

IGES Import Summary Window:

OK

Finally, we will change the model view and render style using the following Toolbar Icons:



Isometric View 3



Shaded Smooth

Your model should look like the figure below

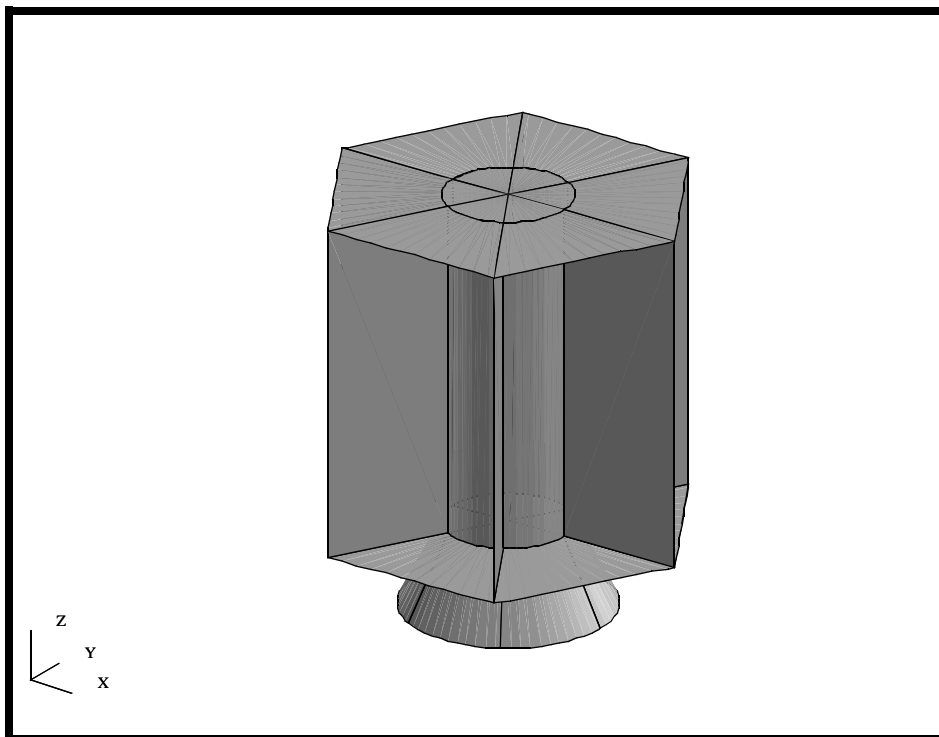

4. We will now create two groups which will help us define the Radiation Loads & BC's. The first group will contain the central cylinder enclosure and the second group will define the remaining external surfaces.

We will change the model view and render style using the following Toolbar Icons:



Front View



Wireframe

Next, we will change our enclosure picking preferences to enable us to easily pick the selected surfaces. Since this is the default "Enclosure Picking", your form may already be set to this option.

Preferences/Picking...

Rectangle/Polygon Picking

Enclose entire entity

Close

Now, we will create a group for the Cylinder Enclosure. For the surface selection, refer to the figure below.

Group/Create...

New Group Name

Central Core

Make Current

Unpost All Other Groups

Group Contents

Add Entity Selection

Entity Selection

Select the surfaces shown in the figure below

We will be making this selection using a polygon pick. To create a polygon pick in MSC.Patran, start by either holding down on the <CTRL> key when you start to pick or by selecting the following icon from the Toolbar.



Polygon Pick

Once you have enclosed the proper entities, you can double-click to complete the selection

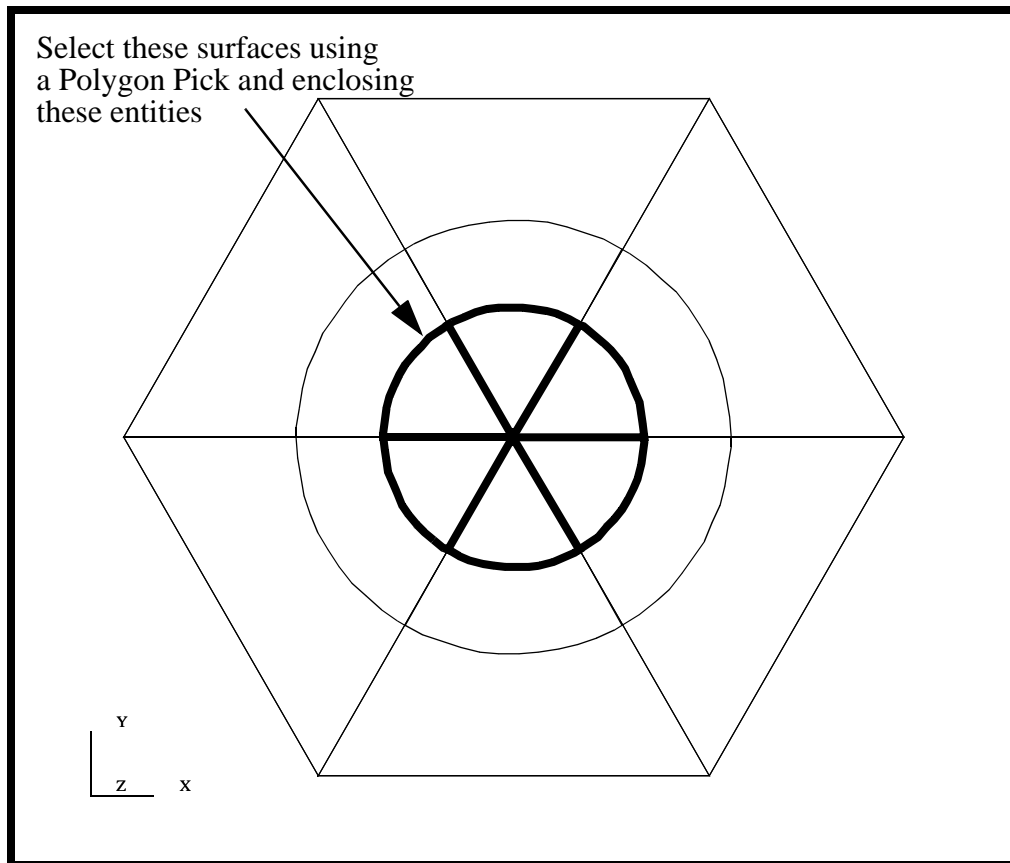

Once you have finished selecting the proper members, complete the creation of the group.

Apply

- We will now create a Group that will contain ALL geometry except the Central Core group. This will be done in two steps. We will first create a group with everything in it, then we will subtract the surfaces the makeup the Central Core.

Group/Create...

New Group Name

External Surfaces

Make Current

Unpost All Other Groups

Group Contents

Add All Geometry

Apply

Action

Post

Select Groups to Post

All Geometry

Central Core

External Surfaces

default_group

Apply

Finally, we will now subtract out the Central Core surfaces from the External Surface group.

Action

Modify

Change Target Group

Change Target Group Form

All Geometry

Central Core

External Surfaces

default_group

Cancel

Member List to Add/Remove

Select all
posted surfaces

-Remove-

OK

The two groups you have created are shown in the figure below.

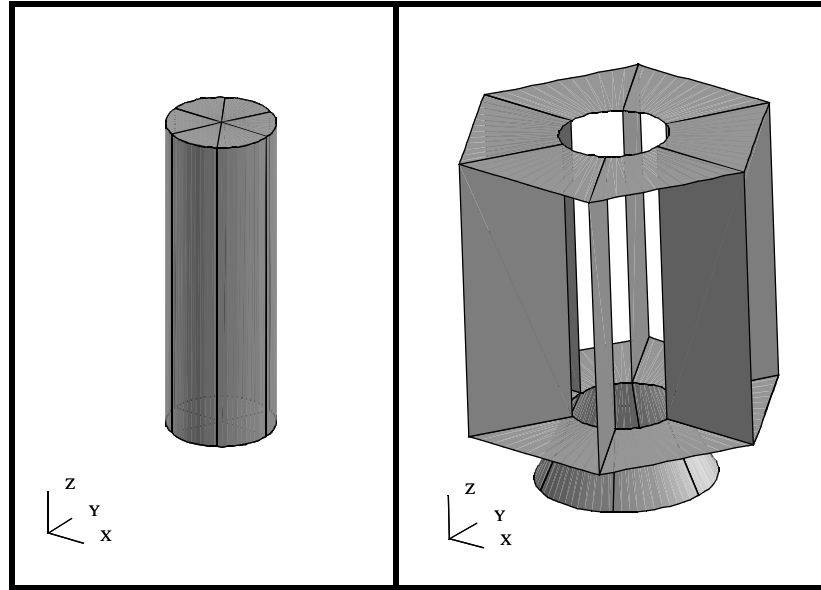

6. Verify the surface normals for the Central Core group.

We will be performing a radiation analysis. The Central Core group has two different radiation sets it participates. The first radiation set is the inside of the cylinder core. The surfaces that make up the inside of the central core radiates onto itself. The second radiation is the outside of the cylinder which radiates out to deep space. We will use the surface normals to determine the top/bottom of the surfaces and try to orientate the surfaces such that they are either all pointing in or out of the enclosure. Thus, top and bottom will be consistent for all Central Cylinder surfaces. This way we can determine the face to apply the internal and external radiation.

Lets start by orientating the Central Core cylinder.



Bottom View



Wireframe

◆ **Geometry**

Action:

Object:

Info:

Show

Surface

Normal

Surface List

Select All Posted Surfaces

As shown in the figure below, you will notice that all surface normals point outward except for the bottom face of the cylinder.

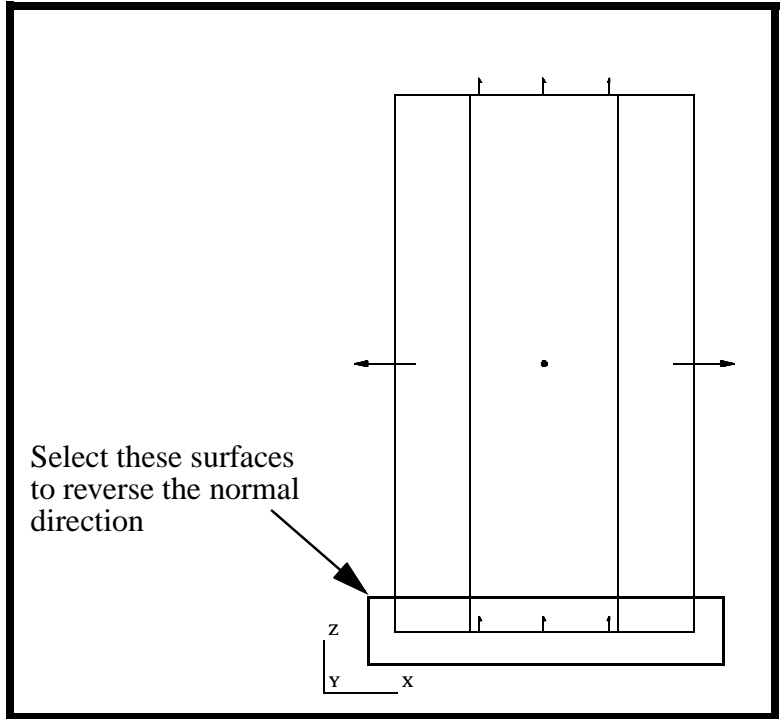

To modify the surface direction, we will use a geometry editing feature.

Action:

Edit

Object:

Surface

Method:

Reverse

Surface List

Select only the bottom surfaces as shown in the figure above

Draw Normal Vectors

Apply

Draw Normal Vectors

-
7. We will now create a mesh for the Central Core Cylinder surfaces.

We will first start by re-orientating the model and render style using the Toolbar



Isometric View 3

Next, we will define a mesh seed. Since most of the heating is going to occur at the ends of the model, we will bias a finer mesh towards the ends and a coarser mesh near the center.

◆ Finite Elements

Action:

Create

Object:

Mesh Seed

Type:

Two Way Bias

Element Edge Length Data

◆ Num Elems and L2/L1

Number

6

L2/L1

3

Curve List

Select any of the vertical long surface edges 

Your model should look like the following figure.

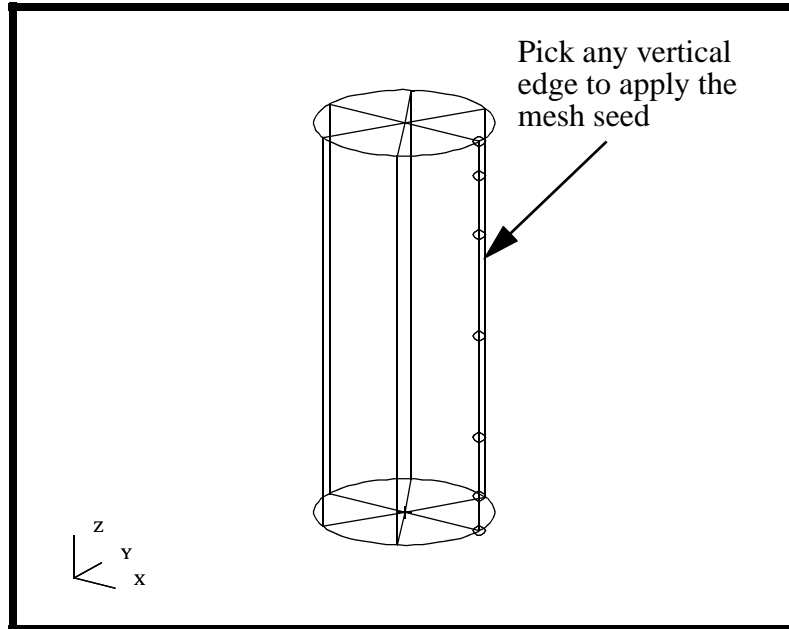

Finally, we will mesh the Central Core using the IsoMesher.

<i>Action:</i>	<input type="button" value="Create"/>
<i>Object:</i>	<input type="button" value="Mesh"/>
<i>Method:</i>	<input type="button" value="Surface"/>
<i>Global Edge Length</i>	<input type="text" value="8"/>
<i>Element Topology</i>	<input type="button" value="Quad8"/>
<i>Mesher</i>	<input checked="" type="checkbox"/> IsoMesher
<i>Surface List</i>	<input type="button" value="Select all posted Surfaces"/>
<input type="button" value="Apply"/>	

Your model should look like the figure below.

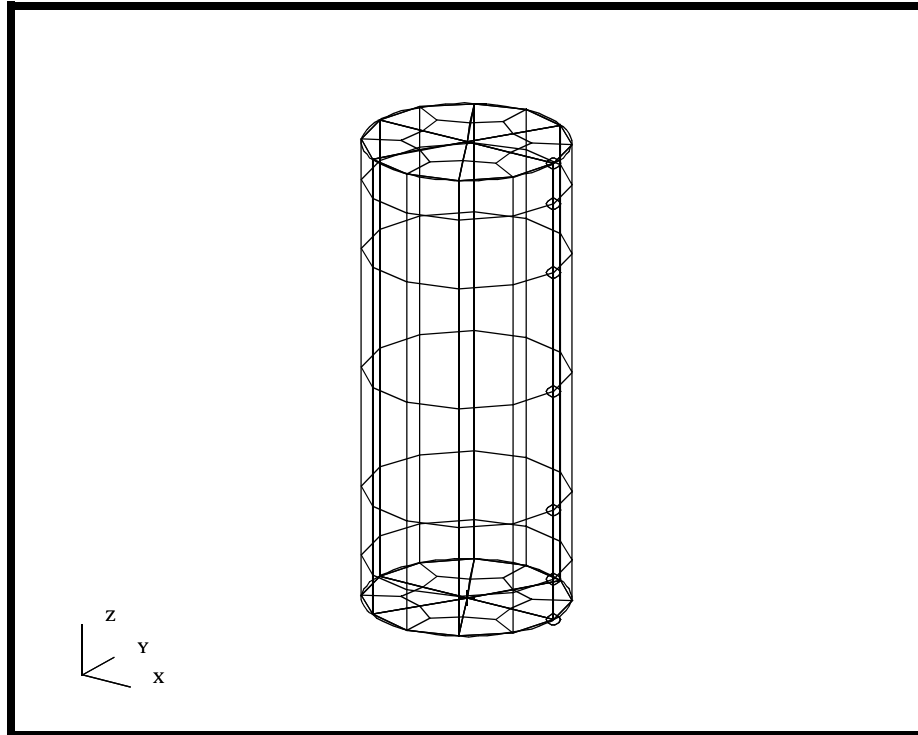

8. We will now create a mesh for the External Surface group.
First post the External Surface group.

Group/Post...

Select Groups to Post

- | |
|--------------------------|
| All Geometry |
| Central Core |
| External Surfaces |
| default_group |

Apply

Cancel

Now mesh the External surfaces using the IsoMesher. This time we will use a Global Edge length of 10 units.

Action: **Create**

Object: **Mesh**

Type: **Surface**

Global Edge Length **10**

Element Topology **Quad8**

Mesher

IsoMesher

Surface List

Select all posted Surfaces 

Apply

Your model should look like the figure below.

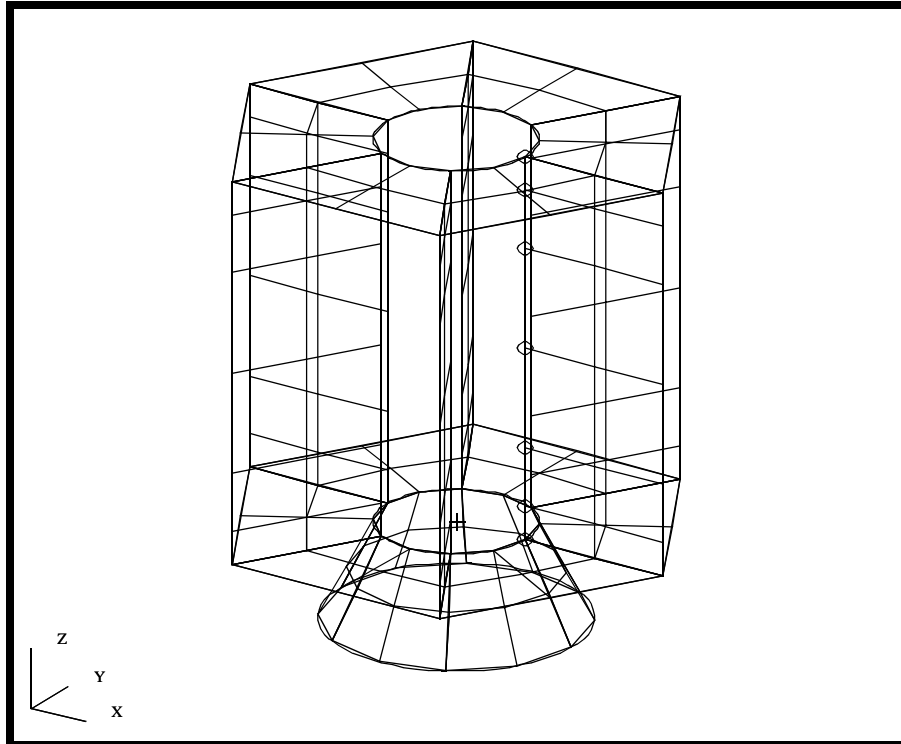

9. In this step we will create a group for all finite elements.

Group/Create...

New Group Name

All Fem

Make Current

Unpost All Other Groups

Group Contents:

Add All FEM

Apply

Cancel

Set the View and Render Style using the Toolbar.



Isometric View 3



Smooth Shaded

Your Model should now look like the figure below.

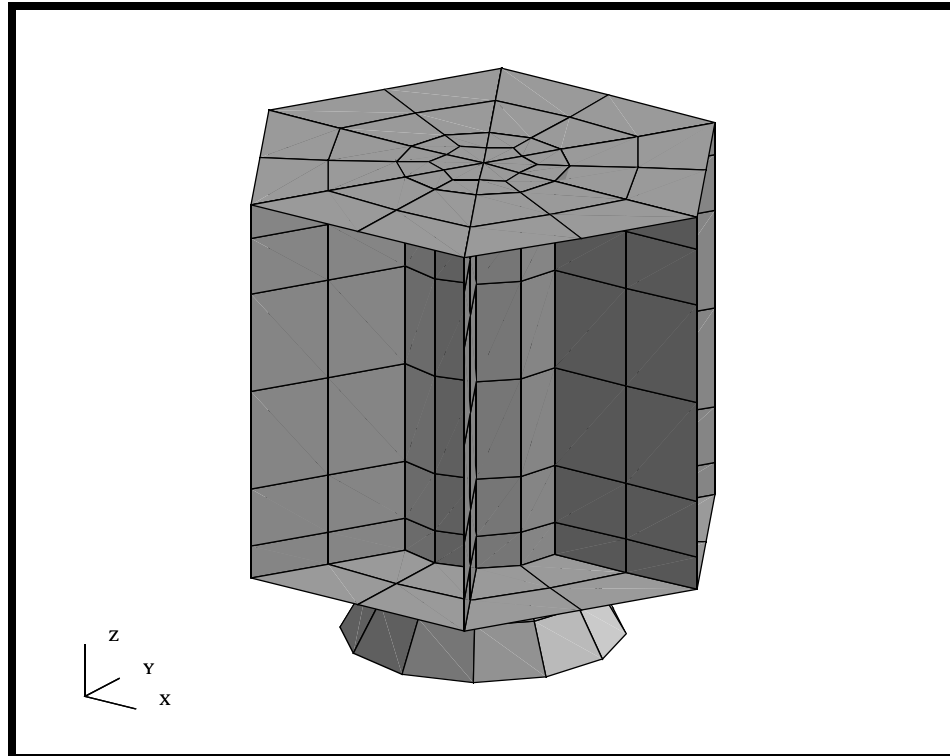

Lets change the render style back to wireframe using the Toolbar icon shown below.



Wireframe

10. Equivalence the Satellite model and then verify the element boundaries.

By equivalencing the model, all duplicate nodes will be removed. Hence, the finite element model represents the object as a single solid piece.

Action:

Equivalence

Object:

All

Method:

Tolerance Cube

Apply

As the equivalencing process proceeds, the locations which have been modified will be identified by circles. Verify the Element Boundaries.

Action:

Verify

Object:

Element

Test:

Boundaries

Apply

You should only see the exterior edges of the satellite, as shown in the figure below.

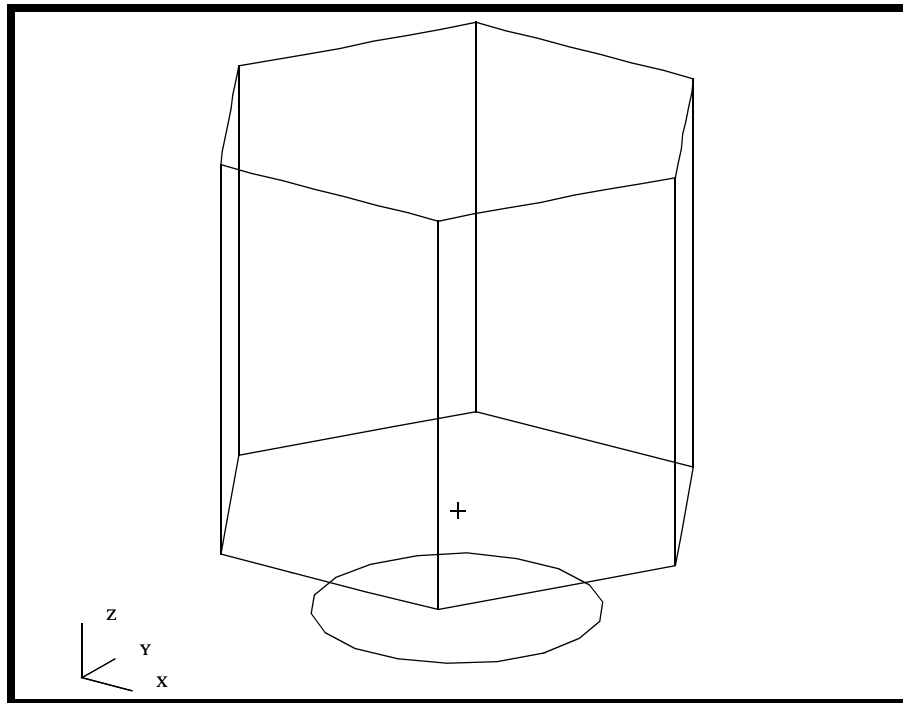

Make sure to reset the graphics to re-render the model before you proceed

Reset Graphics

11. In the following steps, we will set up the radiation loads and boundary conditions for the Central Core group.

We will start by posting the with the Central Core group.

Group/Post...

Select Groups to Post

All Fem
All Geometry
Central Core
External Surfaces
default_group

Apply

Cancel

The are three thermal load and boundary conditions that need to be defined for the Central Core. The first involves the heating form the electronics packages. This will be applied as a thermal flux to the ends of the cylinder. The second conditions is internal radiation. Since the

Core fully enclosed, we will define an enclosure radiation. Finally, the outside of the Core radiates to deep space. For this boundary condition, we will define radiation to ambient space.

It should be noted, we orientated the Surface Normals (and as a result, the element normals) to point outward. Thus, the “Top” face of the elements is on the outer surface of the cylinder. Before we get started, lets change the view using the Toolbar.



Bottom View

We will now define the applied heat load. The applied heat loading is created by the electronics packages mounted on the top and bottom surfaces. These packages control the Navigation, Propulsion and Space Experiments subsystems. The Packages are assumed to be distributed uniformly across the ends of the Central Core as shown in the figure below.

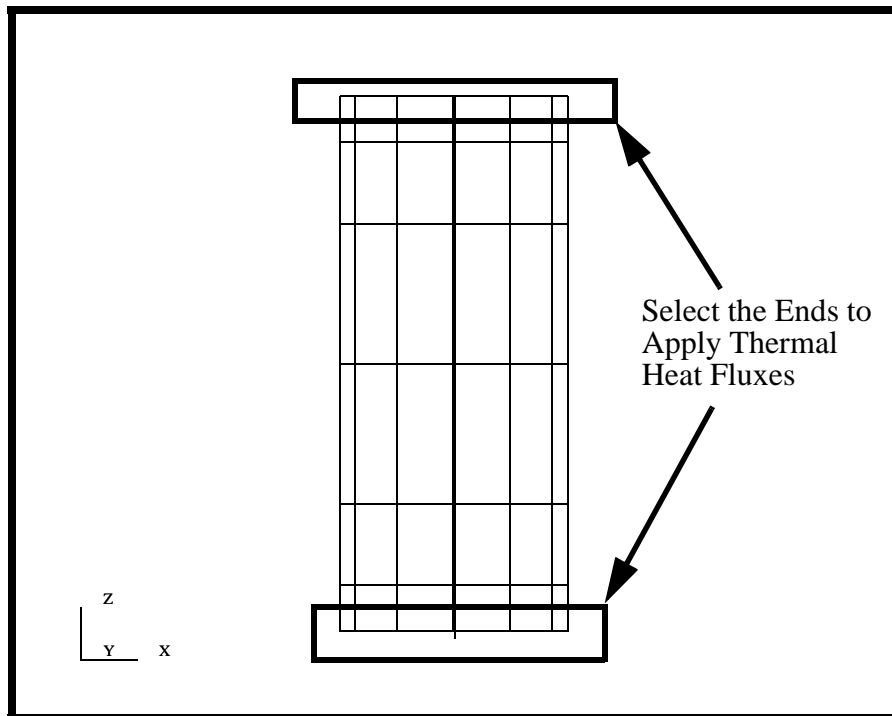

◆ **Loads/BC's**

Action:

Create

Object:

Applied Heat

Type:

Element Uniform

Option:

Normal Fluxes

New Set Name

Electronics Heating

Target Element Type

2D

Input Data...

Surface Option

Bottom

Bottom Surf Heat Flux

2.0

OK

Select Application Region...

Geometry Filter

◆ Geometry

Select Surfaces or Edges

Select cylinder ends as shown in the figure above

Add

OK

Apply

Your model should now look like the following figure.

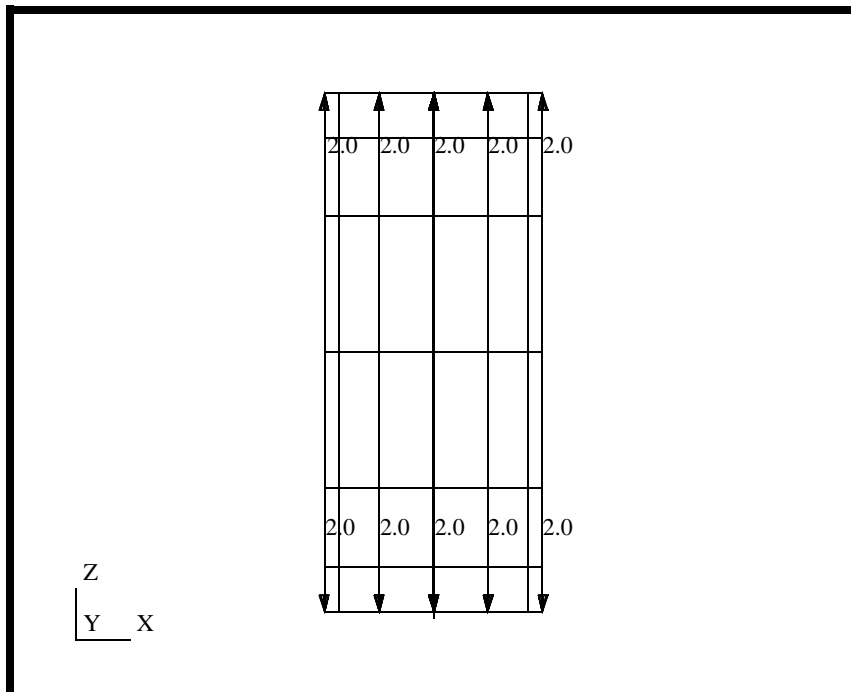

12. Create the Internal Enclosure Radiation for the Central Core.

<i>Action:</i>	<input type="text" value="Create"/>
<i>Object:</i>	<input type="text" value="Radiation"/>
<i>Type:</i>	<input type="text" value="Element Uniform"/>
<i>Option:</i>	<input type="text" value="Enclosures"/>
<i>New Set Name</i>	<input type="text" value="Core - Rad - Internal"/>
<i>Target Element Type</i>	<input type="text" value="2D"/>
<input type="button" value="Input Data..."/>	
<i>Surface Option</i>	<input type="text" value="Bottom"/>
<i>Bottom Surf Emissivity</i>	<input type="text" value="0.9"/>
<i>Enclosure ID</i>	<input type="text" value="100"/>
<input type="button" value="OK"/>	
<input type="button" value="Select Application Region..."/>	
<i>Geometry Filter</i>	◆ Geometry
<i>Select Surfaces or Edges</i>	<input type="text" value="Select all posted surfaces"/>
<input type="button" value="Add"/>	
<input type="button" value="OK"/>	
<input type="button" value="Apply"/>	

The resulting application of this LBC should have all added radiation markers (arrows) pointing to the inside of the cylinder.

13. Create the External Radiation for the Central Core. All these surfaces are assumed to point to deep space. As a result, we will use the Ambient Space option for defining radiation and define the Ambient Temperature condition as 0 degrees Kelvin.

<i>Action:</i>	<input type="text" value="Create"/>
<i>Object:</i>	<input type="text" value="Radiation"/>
<i>Type:</i>	<input type="text" value="Element Uniform"/>

Option:

Ambient Space

New Set Name

Core - Rad - Outside

Target Element Type

2D

Input Data...

Surface Option

Top

Top Surf Emissivity

0.5

Top Surf Absorbitivity

0.5

Ambient Temperature

0.0

View Factor

1.0

OK

Select Application Region...

Geometry Filter

◆ **Geometry**

Select Surfaces or Edges

Select all posted
surfaces 

Add

OK

Apply

The resulting application of this LBC should have all added radiation markers (arrows) pointing to the outside of the cylinder.

14. Finally, create the top and bottom surface radiation conditions for all remaining external surfaces. All surfaces will be assumed to be exposed to deep space.

Lets start by posting the External Surface group.

Group/Post...

Select Groups to Post

All Fem
All Geometry
Central Core
External Surfaces
default_group

Apply

Cancel

Now define the Radiation for the external surfaces

<i>Action:</i>	<input type="text" value="Create"/>
<i>Object:</i>	<input type="text" value="Radiation"/>
<i>Type:</i>	<input type="text" value="Element Uniform"/>
<i>Option:</i>	<input type="text" value="Ambient Space"/>
<i>New Set Name</i>	<input type="text" value="External - Rad - Top"/>
<i>Target Element Type</i>	<input type="text" value="2D"/>
<input type="button" value="Input Data..."/>	
<i>Surface Option</i>	<input type="text" value="Top"/>
<i>Top Surf Emissivity</i>	<input type="text" value="0.5"/>
<i>Top Surf Absorbivity</i>	<input type="text" value="0.5"/>
<i>Ambient Temperature</i>	<input type="text" value="0.0"/>
<i>View Factor</i>	<input type="text" value="1.0"/>
<input type="button" value="OK"/>	
<input type="button" value="Select Application Region..."/>	
<i>Geometry Filter</i>	◆ Geometry
<i>Select Surfaces or Edges</i>	<input type="text" value="Select all posted surfaces"/>
<input type="button" value="Add"/>	
<input type="button" value="OK"/>	
<input type="button" value="Apply"/>	

Repeat the previous step defining a new load condition, “**External - Rad - Bottom**”. Only this time use the *Surface Option* = “**Bottom**”. Use the same values for Emissivity, Absorbivity, Ambient Temperature and View Factor.

15. Create an Isotropic material, named **aluminum**, which uses the Solid Properties Constitutive Model. Only the Thermal Conductivity will need to be defined. The material's Thermal Conductivity is 5 watts/degree K

◆ **Materials**

<i>Action:</i>	Create
<i>Object:</i>	Isotropic
<i>Method:</i>	Manual Input
<i>Material Name</i>	aluminum
Input Properties...	
<i>Constitutive Model</i>	Solid properties
<i>Thermal Conductivity =</i>	5.0
OK	
Apply	

16. In this section, we will create properties for all 2D Shell elements. For purposes of this model, we will assume the thickness of the structure is uniformly 0.125 units and is made of aluminum material.

Since the property definition will be applied to the geometry, we will start by posting the All Geometry group.

Group/Post...

<i>Select Groups to Post</i>	All Fem
	All Geometry
	Central Core
	External Surfaces
	default_group
Apply	
Cancel	

Clean up the display using the Reset Graphics icon from the Main Form.



Reset graphics

**Defining
Shell
Elements**

Next, we will define a uniform property for the entire satellite. Again, the thickness is 0.125 and the material is aluminum.

◆ Properties

Action:	<input type="text" value="Create"/>
Object:	<input type="text" value="2D"/>
Type:	<input type="text" value="Shell"/>
Property Set Name	<input type="text" value="Thermal Shell"/>
<input type="button" value="Input Properties..."/>	

In the *Input Properties...* form, click in the *Material Name* data box. The material properties available for selection will appear in the Material Property Sets list.

Select the aluminum material from the list. The selected material name will appear with the prefix “**m:**” in the *Material Name* data box.

Material Name	<input type="text" value="aluminum"/>
Thickness	<input type="text" value="0.125"/>
<input type="button" value="OK"/>	
Select Members	<input type="text" value="Select All Posted Surfaces"/>
<input type="button" value="Add"/>	
<input type="button" value="Apply"/>	

- We are now ready for analysis. In this step, you will define the analysis and write out an Input deck. We will be submitting a Steady State Thermal analysis and you will be using the **Default** subcase. The Default subcase is an analysis solution which uses the corresponding **Default** load case.

Before we finish this step, let's change the group, render style, and view to see the changes we have made to the model.

Group/Post...

Setup the Analysis

Select Groups to Post

All Fem
All Geometry
Central Core
External Surfaces
default_group

Apply

Cancel

Now change the render style and view using the Toolbar.



Isometric View 3



Shaded Smooth

Your model should now look like the figure below.

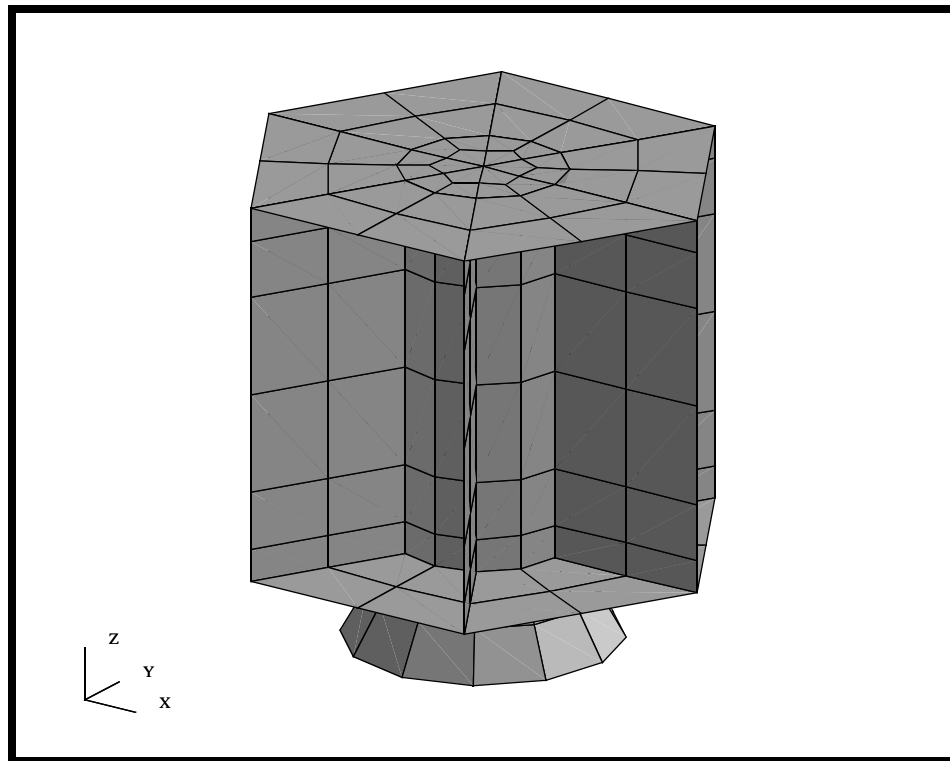

Now define the steps to create the analysis model.

◆ Analysis

Action:

Analyze

<i>Object:</i>	<input type="text" value="Entire Model"/>
<i>Method:</i>	<input type="text" value="Full Run"/>
<input type="text" value="Translation Parameters..."/>	
<i>Data Output:</i>	<input type="text" value="Op2 and Print"/>
<i>OUTPUT2 Format:</i>	<input type="text" value="Text"/>
<input type="text" value="OK"/>	
<input type="text" value="Solution Type..."/>	
<i>Solution Type</i>	◆ Steady State Analysis
<input type="text" value="Solution Parameters..."/>	
<i>Default Init Temperature</i>	<input type="text" value="400.0"/>
<input type="text" value="Radiation Parameters..."/>	
<i>Stefan-Boltzmann Constant</i>	<input type="text" value="3.6580E-11 WATTS/IN2/K4"/>
<input type="text" value="OK"/>	
<input type="text" value="OK"/>	
<input type="text" value="OK"/>	

In MSC.Nastran, a subcase provides a tool to associate loads and boundary conditions, output requests and various other parameters depending on the solution type selected. These subcases are essential to perform structural and thermal analysis of structures.

For this analysis, we will be using the Default Subcase. Each solution type has an associated Default Subcase. The default Subcase includes subcase specific parameters, output requests and other specific parameters. You can access the Subcase information from the **Subcase Create...** button. You will notice the Default subcase has already been created. The name of the subcase is the same as the loadcase which is **Default**. This subcase consists of the Default load case, and the requested outputs that can be inspected by pressing the *Output Requests* button.

To submit the analysis, just select Apply in the main Analysis form.

When the job is finished, we will use these results to post-process the analysis and also use these results to map onto a structural model.

18. Monitor the Analysis.

If you have Analysis Manager installed on the system, you will see a Graphical User Interface (GUI) which shows you how the job is proceeding, errors, CPU and Disk usage. Look for any Errors in the Mon File window. When the job is finished, simply Close the Analysis Manager Job Graph window

Close

If you do not have Analysis Manager installed, you can monitor the analysis by opening a shell on the same system/directory location. In UNIX, you can type in the following command:

```
tail -l radiation.f06
```

This will display any messages normally output to the F06 file to the shell while the job is running. These messages will also tell you the progress of the job and whether the analysis was successful or not.

Regardless of which method you used to submit and monitor the analysis, look for any errors that may have occurred. If you have any errors, ask the instructor for assistance. If the job completes normally, proceed onto the next step to read the results back into MSC.Patran.

19. Read the results back into MSC.Patran

We will now read in the results back into MSC.Patran. This is done thru the Analysis form.

◆ **Analysis**

Action:

Read Output2

Object:

Result Entities

Method:

Translate

Select Results File...

Select Results File:

radiation.op2 

Note: this can be selected from the Available Files list

OK

Apply

20. Post-process the temperature results.

We will now post process the results for the Radiation/Thermal analysis. We will start by looking at the temperature profile for the steady state analysis. We have assumed the satellite is shadowed by the earth and mostly seeing deep space (0 degrees Kelvin) for the radiation analysis. The heating has come from the internal electronic packages placed at the ends of the Central Core.

We will use Quick Plot to generate the temperature variation on the model.

◆ Results

Action:

Create

Object:

Quick Plot

Select Result Case(s)

Default, PW Linear:
100.% of Load

Select Fringe Result

Temperatures,

Apply

Your model should look like the one shown below.

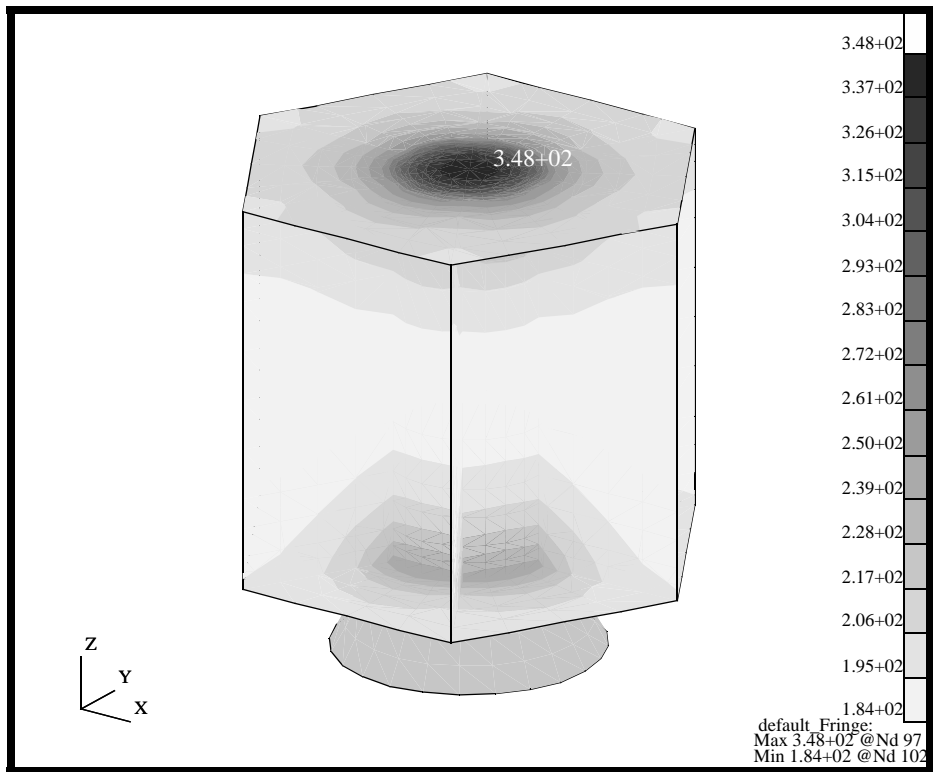

21. Now lets modify some of the Fringe Attributes of this plot.



Each type of result display has several methods of controlling how the results are controlled. Quick Plot assumes the elements to be post processed is all the elements in the graphics window. From this form, we can control how fringe and deformation results get displayed and how models are to be animated. We will now modify the “standard” Quick Plot.

<i>Action:</i>	Create
<i>Object:</i>	Quick Plot
<i>Select Result Case(s)</i>	Default, PW Linear: 100.% of Load
<i>Select Fringe Result</i>	Temperatures,

To change the fringe display click on the Fringe Attributes icon in the results form.

Fringe Attributes

We will now change many of the Fringe Attributes to see their affect on the results display.

<i>Style:</i>	Continuous
<i>Element Shrink Factor:</i>	0.3 
<i>Display:</i>	Element Edges
<i>Style:</i>	
Apply	

Finally, reset your view using the Toolbar icon.



Isometric View 3

Your model should now look like the figure below.

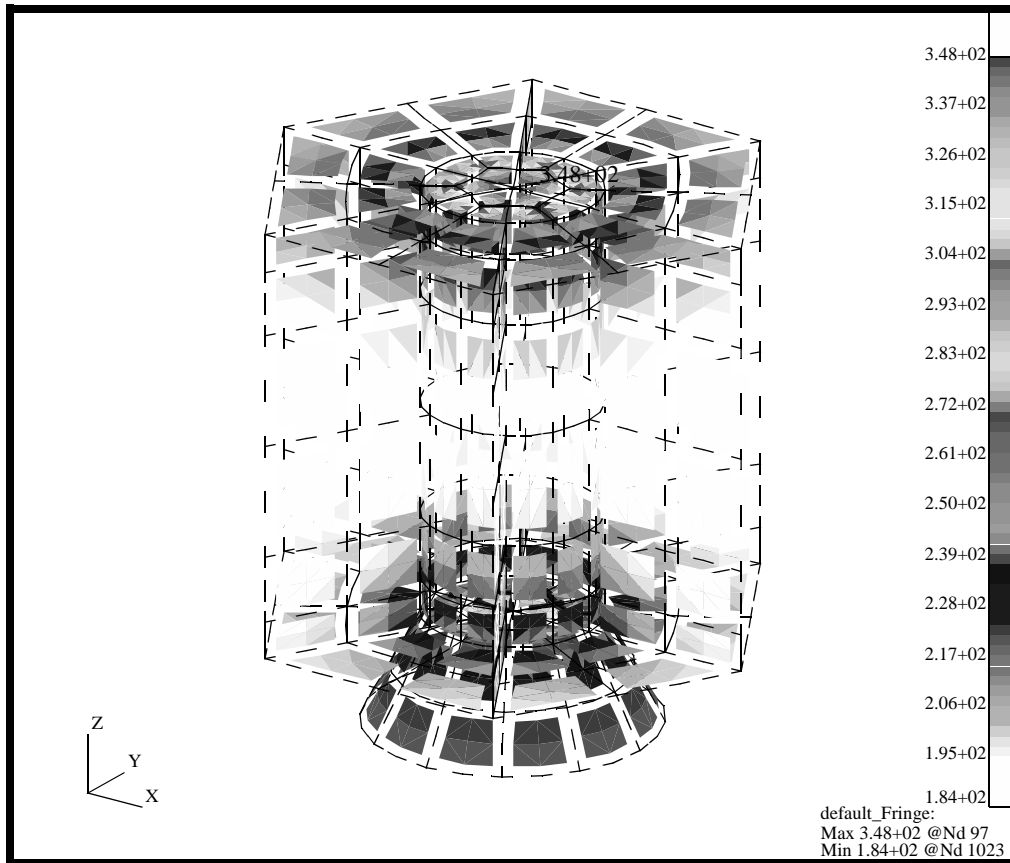

In a later exercise, you will be mapping these temperatures onto a structural model and using this temperature profile as an input, an applied loading, for a structural analysis.

We are now done with this exercise. Before we continue, clean up the display using the Reset Graphics icon from the Main Form.



Reset graphics

22. To complete this exercise, you will close the database.

File/Quit

This will exit MSC.Patran and close your file. Do not delete the database from your directory since you will use it for future exercises.

It should be noted that all changes made to the database are automatically saved and there is no need to perform a save operation.

**Close the
Database
and Quit
MSC.Patran**

