

---

## Exercise11

# *Mapping of Thermal Results onto a Structural Space Satellite Model*

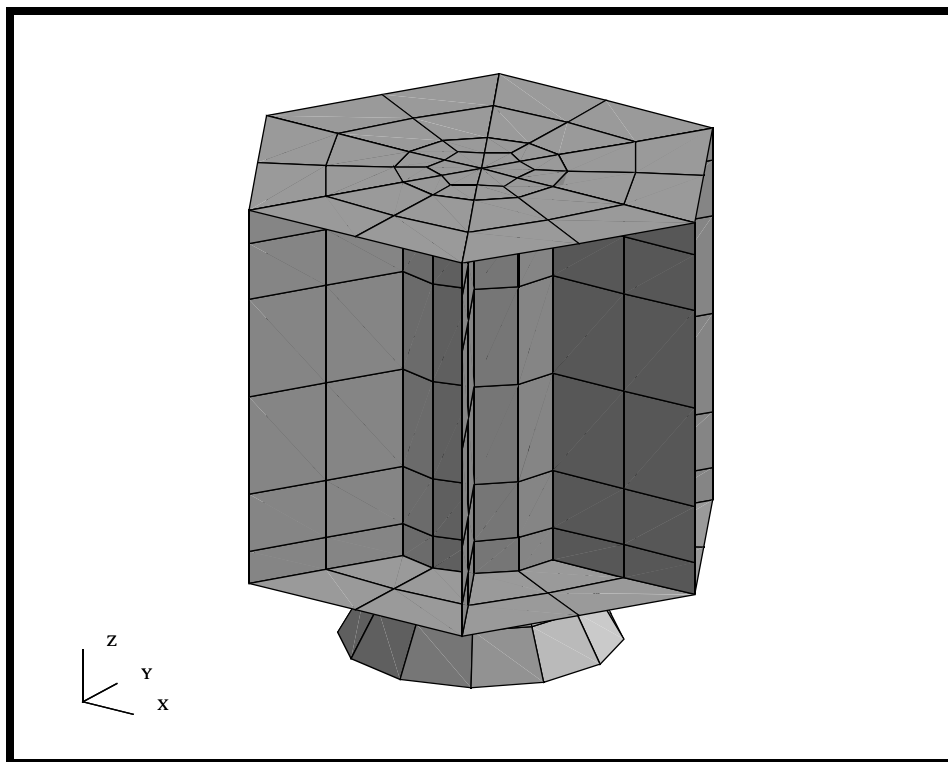

### **Objectives:**

- Map temperature results of a Convection-Radiation Analysis onto a Structural model.
- Submit Structural Model for Analysis by Group



## Model Description:

In this exercise, you will use the temperature profile from a thermal analysis (convection/radiation analysis) and map these results onto a structural model. The two models are meshed with different mesh densities and element types (Quad4's vs. Quad8's). MSC.Patran will handle this difference by using nodal interpolation of the results onto the structural model. In order to do this exercise, we will create a new database and import both the structural and thermal models. We will also import the thermal results into the same database. We will then do the mapping of results onto the structural model and write out the MSC.Nastran input deck. Since this database contains both a structural and a thermal model, we will write out the model using Analyze/Group as opposed to Analyze/Entire model. Finally, perform a thermal static free expansion analysis of the satellite based on a reference temperature of room temperature.

The model data could have come from any analysis solver. All that is needed for a thermal mapping type problem is that you supply enough information to create a fringe plot of the temperature profile. Usually, all that is necessary is nodes, elements and the scalar temperature results. It should be also noted that MSC.Patran is capable of doing more complex mappings, such as 2D to 3D type mappings (axisymmetric and planar to 3D spatial model). For this analysis we will be doing a straight forward 3D spatial mapping.

## Suggested Exercise Steps:

- Start MSC.Patran and open the database **thermal\_map.db**
- Create a group for the thermal model, **thermal**, which will be used to contain all the thermal model entities.
- Use the Analysis form to import both the model data and results from the **radiation.op2** that was obtained from the of the radiation analysis performed earlier
- Create a group for the structural model, **structural**, which will be used to contain all the structural model entities.
- Use File/Import to import the structural analysis model, **satellite.db**, into the current database
- Post the thermal model group.
- Create a fringe result of the temperature profile.
- While the results are visible, create a continuous scalar FEM

---

field of the results.

- Reset the graphics and post the structural model group.
- Create a new load and boundary condition for the applied temperature.
- Create an additional displacement condition to constrain the vehicle at the independent node of the Propulsion Module rigid fixed MPC.
- Modify the material properties to include the thermal coefficient of expansion properties and reference temperature.
- Create an Load Case that contains the Initial Temperature, Temperature Profile and Free Expansion Constraint.
- Use Analysis, Analyze/Current Group to submit the structural model for analysis.
- Once the analysis has finished, read in the output2 results file.
- Post process the results and plot the free expansion contraction of the satellite model in its on-orbit configuration
- Close and Quit MSC.Patran.

## Exercise Procedure:

1. Open a new database and name it **thermal\_map.db**.

Open a New Database

File/New...

New Database Name

thermal\_map

OK

New Model Preference

Tolerance

◆ Default

Analysis Code

MSC/NASTRAN

Analysis Type

Structural

OK

2. In this step, we will create a group for the Thermal model. By doing this step first, all the thermal model entities imported into this database will automatically be added to this group.

Group/Create...

New Group Name

thermal

Make Current

Unpost All Other Groups

Apply

Cancel

3. We will now read in the thermal model. We will read in the results and model entities from the thermal.op2 file

We will now read the results and model data into MSC.Patran. This is done thru the Analysis form.

◆ Analysis

Action:

Read Output2

Object:

Both

Method:

Translate

Select Results File...

Select Results File:

radiation.op2

Note: this can be selected from the Available Files list

OK

Apply

Finally, we will change the model view and render style using the following Toolbar Icons:



Isometric View 3



Shaded Smooth

Your model should look like the figure below.

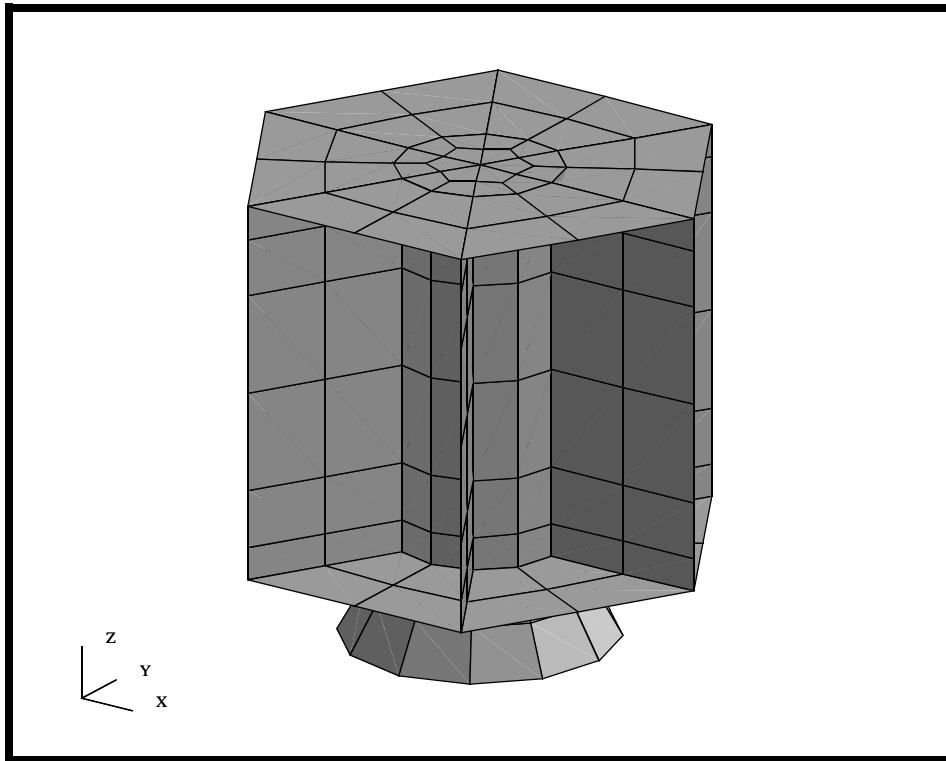

4. In this step, we will create a group for the Structural model. Again, by doing this step first, all the structural model entities imported into this database will automatically be added to this group. To not clutter the display, we will also unpost the existing thermal group.

**Group/Create...***New Group Name***structural**

- Make Current**  
 **Unpost All Other Groups**

**Apply****Cancel**

5. Use file import to import the structural model of the satellite model created in the previous Satellite exercise.

This step will import the model data from the original structural satellite database. All pre-processing information, such as Geometry, FEM, Loads & Boundary conditions, Materials, Element Properties and Groups will be imported into this database. In addition, all entities will be added to the current group, the structural group. We will use the Equivalence Options so that none of the nodes or elements from the structural database are equivalenced with the thermal model data already contained in the new database.

**Import the  
Satellite  
Database**

**File/Import...***Object:***Model***Source:***MSC/PATRAN DB***Import File***satellite.db**

Note: this can be  
selected from the  
PATRAN Databases  
list

**Equivalence Options...***Equivalence Nodes/Geometry*

- Nodes**  
 **Geometry**

**OK****Apply**

---

Once the import is completed, you will get a summary window listing all the MSC.Patran entities imported into the new database.

*PATRAN Database Import*  
*Summary window*

OK

Finally, we will change the model view and render style using the following Toolbar Icons:



**Isometric View 3**



**Shaded Smooth**

The structural model should look like the figure below.

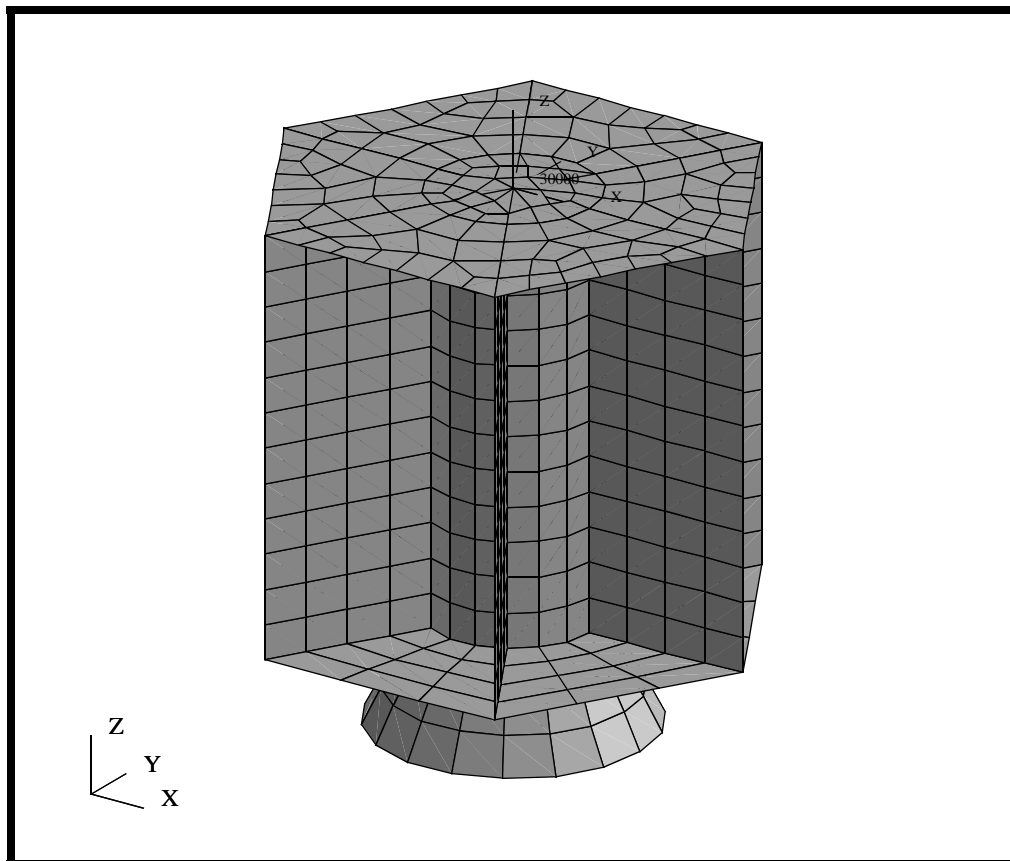

You will note the mesh density and element of the thermal model and structural model are different. In addition, the element types are also different. The structural model is primarily composed of bar2 and Quad4 elements. The thermal model is made of Quad 8 elements. This will not affect our mapping because we will use continuous nodal interpolation between the two models.

- We will post the thermal group/model for future post processing.

Post the thermal group using Group Post

**Post the thermal Group**

**Group/Post...**

*Select Groups to Post*

- Adapter
- All Fem
- All Geometry
- Central Cylinder
- Lower Platform
- Navigational Platform
- Propulsion Block
- Science Platforms
- Shear Panels
- Upper Platform
- default\_group
- structural
- thermal

**Apply**

**Cancel**

- Create a fringe of the temperature results.

We will now post process the results of the Radiation/Thermal analysis. We will start by looking at the temperature profile for the steady state analysis. We have assumed the satellite is shadowed by the earth and mostly seeing deep space (0 degrees Kelvin) for the radiation analysis. The heating has come from the internal electronic packages placed at the ends of the Central Core.

We will use Quick Plot to generate the temperature variation on the model.

◆ **Results**

*Action:*

**Create**

*Object:*

**Quick Plot**

*Select Result Case(s)*

**Default, PW Linear:  
100.% of Load**

*Select Fringe Result*

**Temperatures,**

Change the fringe display by clicking on the Fringe Attributes icon in the results form.

### Fringe Attributes

We will modify the fringe display to better visualize the results.

*Fringe Edges:*

**Black**



*Display:*

**Element Edges**

**Apply**

Finally, reset your view using the Toolbar icon.



**Isometric View 3**

Your model should look like the one shown below.

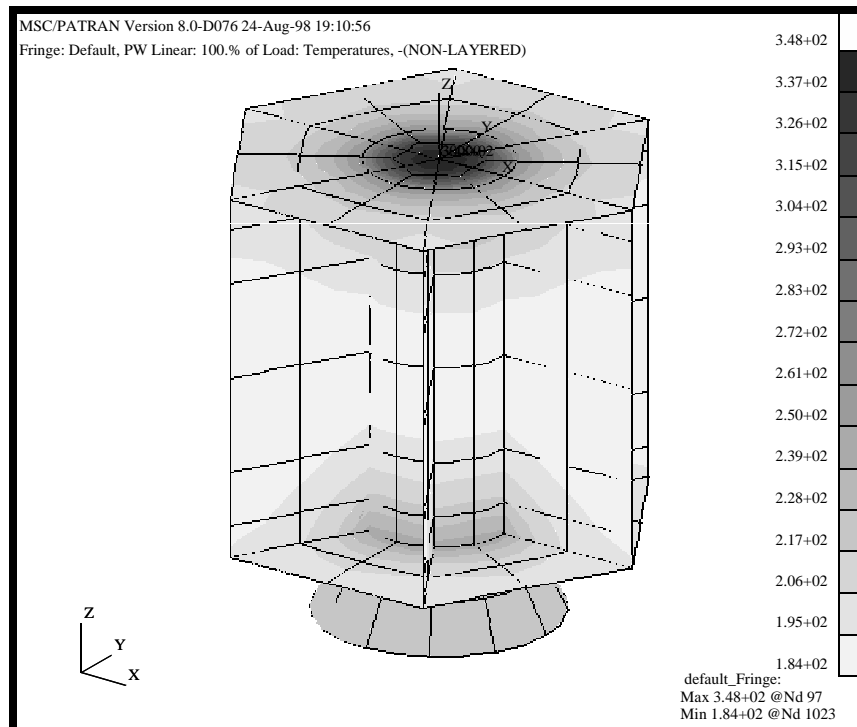

8. We will now create the mapping of the temperature profile. We will create a spatially varying scalar FEM field named **thermal\_profile** that will later be applied to the structural model.

The Spatial FEM Field is the tool in MSC.Patran that allows the mapping of results onto a model for input. You can map both scalar (temperatures) and vector (displacements, velocities, accelerations) type data. There are two types of scalar or vector FEM fields, these are discrete or continuous. A discrete Mapping is used when the user does NOT wish for any interpolation to occur. This would be used when there is an element to element or node to node correspondence.

The other type of FEM Field is a continuous field. Continuous FEM fields are used when there is not a one to one mapping of nodes or elements. In this case, linear interpolation is performed. In addition, continuous FEM fields allows users to map 2D results (axisymmetric or planner) onto 3D models.

#### ◆ Fields

<i>Action:</i>	<input type="text" value="Create"/>
<i>Object:</i>	<input type="text" value="Spatial"/>
<i>Method:</i>	<input type="text" value="FEM"/>
<i>Field Name</i>	<input type="text" value="thermal_profile"/>
<i>FEM Field Definition</i>	◆ Continuous
<i>Field Type</i>	◆ Scalar
<i>Mesh/Results Group Filter</i>	◆ Current Viewport
<i>Select Group</i>	<input type="text" value="thermal"/>

The Options... button allows control of 2D to 3D mappings as well as how to handle results extrapolation (note: extrapolation, not interpolation). The default extrapolation is closest table value. Since our models lie in relatively common space, we will stick with the default, however, if you had models that did not occupy the same space, you could alternatively choose linear extrapolation or set value to zero.

## Post the thermal Group

- We will now post the structural group/model so the temperature profile can be mapped onto the model.

We are now done with the thermal model and fringe results. Before we continue, clean up the display using the Reset Graphics icon from the Main Form.



### Reset graphics

Post the structural group using Group Post

### Group/Post...

*Select Groups to Post*

Adapter
All Fem
All Geometry
Central Cylinder
Lower Platform
Navigational Platform
Propulsion Block
Science Platforms
Shear Panels
Upper Platform
default_group
<b>structural</b>
thermal

Apply

Cancel

- In the following steps, we will set up all the loads and boundary conditions for the free expansion analysis. These loads and boundary conditions will include applied temperature and a constraint for free expansion.

### ◆ Loads/BC's

Action:

Create

Object:

Temperature

Type:

Nodal

New Set Name

steady state temp

Input Data...

# Thermal-Structural Results Mapping

In the *Input Data...* form, click in the *Temperature* data box. The spatial fields available for selection will appear in the Spatial Fields listbox.

Click on **thermal\_profile** under the *Spatial Fields* listbox. The selected field definition name will appear with the prefix “f:” in the *Temperature* data box.

*Temperature* f:thermal\_profile

OK

Select Application Region...

*Geometry Filter* ◆ Fem

*Select Nodes* Select all posted nodes

Add

OK

Apply

We will now verify the temperature mapping prior to continuing on with further loads and boundary condition assignment. Before we continue, clean up the display using the Reset Graphics icon from the Main Form.



**Reset graphics**

Now, plot the temperature contours on the structural model.

*Action:* Plot Contours

*Object:* Temperature

*Existing Sets* steady state temp

*Select Data Variable* Temperature

*Group Filter* ◆ Current Viewport

*Select Groups* structural

Apply

Your model should now look like the following figure.

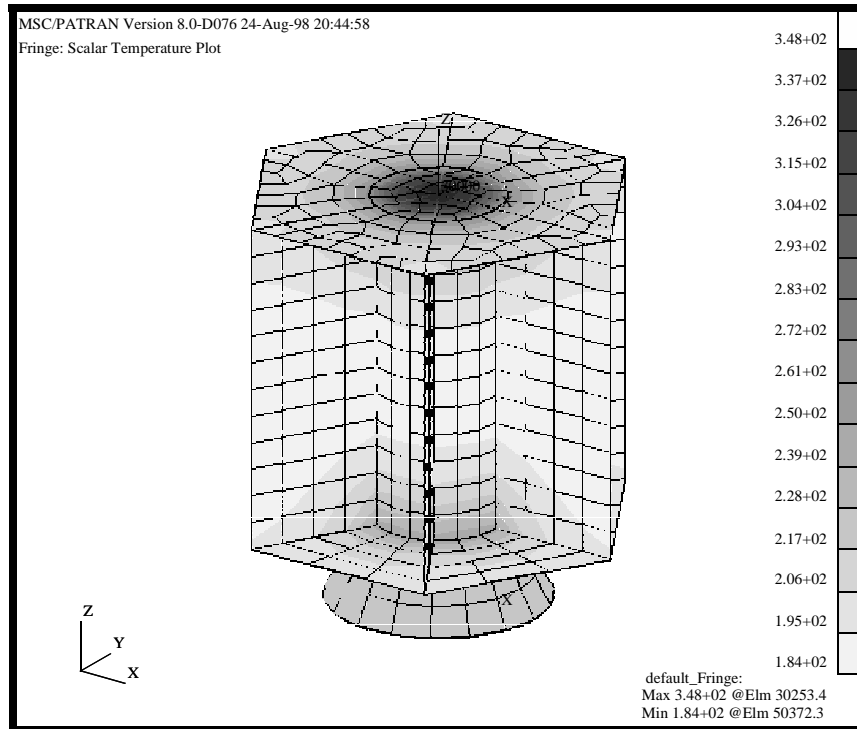

11. We will now create the final load and boundary condition for the free expansion condition.

Clear the fringe plot by resetting the viewport graphics.



**Reset graphics**

We will change the model view and render style using the following Toolbar Icons:



**Rear View**



**Shaded Smooth**

We will now define the free expansion boundary condition

*Action:*

**Create**

*Object:*

**Displacement**

Type:	<input type="text" value="Nodal"/>
New Set Name	<input type="text" value="free free constraint"/>
<input type="button" value="Input Data..."/>	
Translations	<input type="text" value="&lt;0, 0, 0&gt;"/>
Rotations	<input type="text" value="&lt;0, 0, 0&gt;"/>
Analysis Coordinate Frame	<input type="text" value="Coord 20000"/>
<input type="button" value="OK"/>	
<input type="button" value="Select Application Region..."/>	
Geometry Filter	<input checked="" type="checkbox"/> Fem

You will now apply the constraint to the center node of the Lower Surface.

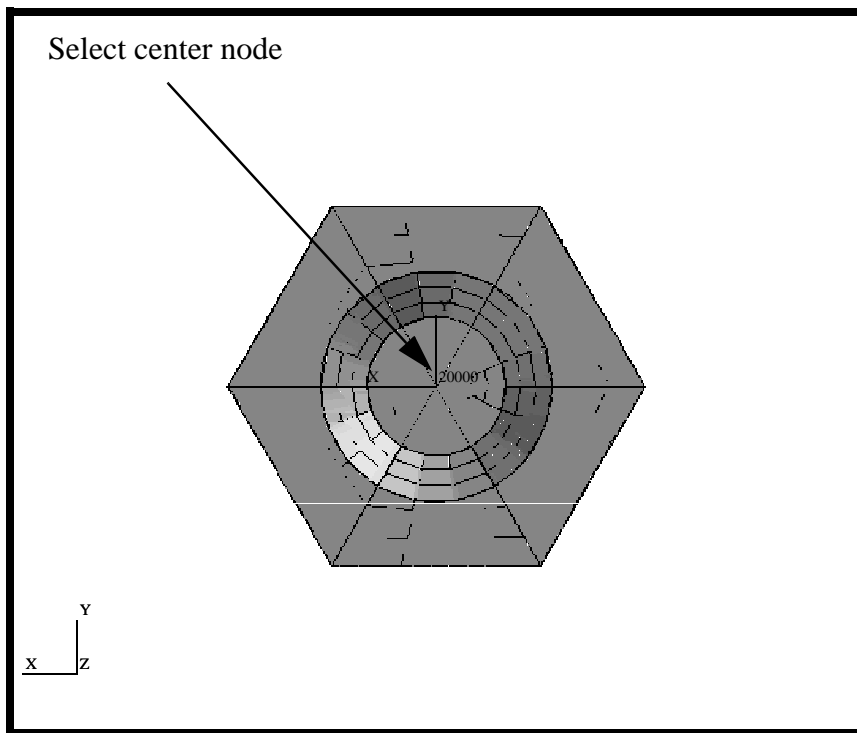

To aid you in making the node selection, it is advisable to turn on the Visible Entities picking. This will only pick the outermost node.



**Pick Visible Entities**

Select Nodes

Select the node located at the center of the adapter cone

Add

OK

Apply

12. We will now modify the titanium and aluminum material properties to include the thermal coefficient of expansion and reference temperature (room temperature).

We will start by modifying the titanium material property. We will define a CTE of  $4.8E-6$  in/in degree F and a room temperature value of 539.6 degrees Rankin.

◆ **Materials**

Action:

Modify

Object:

Isotropic

Material Name

titanium

Input Properties...

Constitutive Model:

Linear Elastic

Thermal Expan. Coef =

$4.8E-6$

Reference Temperature =

539.6

OK

Apply

Repeat the procedure above, but this time for the aluminum material. Define a Thermal Coefficient of Expansion of  $12.6E-6$  in/in deg. F and a Reference Temperature of 539.6 degrees Rankin.

13. Finally, we will define a thermal structural load case for this model. This load case will include the free-free constraint and the applied temperature loads.

◆ **Load Cases**

Action:

Create

Load Case Name

Thermal Structural

**Define a Thermal-Structural Load Cases**

<i>Load Case Type:</i>	<input type="text" value="Static"/>
<input type="text" value="Assign/Prioritize Loads/BCs"/>	
<i>Select Individual Loads/BCs</i>	<input type="text" value="Displ_free free constraint"/>
<i>Select Individual Loads/BCs</i>	<input type="text" value="Tempe_steady state temp"/>

The displacement and temperature should now have been added to your spreadsheet. Before we continue, we will want to modify the temperature profile. The temperature profile is in units of Kelvin. To be consistent with the units used in this analysis, we will need to convert to Rankin. We will do this by applying a scale factor of 1.8 to the temperature profile. Alternatively, we could have scaled the individual Load and Boundary condition or we could have scaled the result prior to making the result profile. All the above methods would have resulted in the same end result. For this analysis we have chosen to make the modification in the Load Case form.

From the list of Assigned Loads/BCs spreadsheet, change the following scale factors

	<b>Scale Factor</b>
<i>free free Constraint</i>	<input type="text" value="1.0"/>
<i>steady state temp</i>	<input type="text" value="1.8"/>

The spreadsheet should now show the scaled temperature profile along with the displacement constraint.

<input type="text" value="OK"/>
<input type="text" value="Apply"/>

- We are now ready for analysis. In this step, you will define the analysis solution type and parameters, a linear static analysis. In later steps, we will setup the subcases, write out an input deck and run the analysis.

## Setup the Analysis

We will begin by defining the subcase for the static on-orbit free expansion condition. It must be noted, that this database contains two distinct models. Thus, we will submit the using the Current Group option (the structural model group).

### ◆ Analysis

<i>Action:</i>	<input type="text" value="Analyze"/>
----------------	--------------------------------------

*Object:*

**Current Group**

*Method:*

**Full Run**

*Job Name:*

**thermal\_mapping**

**Translation Parameters...**

*Data Ouptup:*

**Op2 and Print**

*OUTPUT2 Format:*

**Text**

**OK**

**Solution Type...**

*Solution Type:*

◆ **LINEAR STATIC**

**Solution Parameters...**

*Plate Rz Stiffness Factor =*

**10.0**

*Wt.-Mass Conversion =*

**0.00259**

**OK**

**OK**

**Modify the  
Static  
Subcase**

- Define the subcases for the on-orbit free expansion condition. We will be using the subcase based on the load cases created earlier.

We will additionally request Element Forces and Grid Point Force Balance for the Thermal Expansion analysis.

**Subcase Create...**

*Available Subcases:*

<b>Default</b>
<b>Launch Modal</b>
<b>Launch Static</b>
<b>Thermal Structural</b>

*Subcase Options*

**Output Requests...**

*Select Result Type*

**Element Forces**

*Select Result Type*

**Grid Point Force Balance**

**OK**

**Apply**

**Cancel**

16. We will now select the subcase to analyze.

For this analysis, we will only be analyzing the *Thermal Structural* load case. Therefore, you will need to de-select the Default subcase and select the Thermal Structural subcase.

## Static Analysis Setup

### Subcase Select...

*Subcases For Solution Sequence: 101*

**Thermal Structural**

(Click on this to select)

*Subcases Selected:*

**Default**

(Click on this to deselect)

**OK**

17. Submit and monitor the analysis.

To submit the analysis, just select *Apply* in the main **Analysis** form.

## Submit and Monitor the Analysis

**Apply**

When the job is finished, we will use these results to post-process the analysis.

If you have Analysis Manager installed on the system, you will see a Graphical User Interface (GUI), which shows you how the job is proceeding, errors, CPU and Disk usage. Look for any errors in the *Mon File* window. When the job is finished, simply *Close* the *Analysis Manager Job Graph* window

**Close**

If you do not have Analysis Manager installed, you can monitor the analysis by opening a shell on the same system/directory location. In UNIX, you can type in the following command:

```
tail -l satellite_static.f06
```

This will display any messages normally output to the *F06* file to the shell while the job is running. These messages will also tell you the progress of the job and whether the analysis was successful or not.

Regardless of which method you used to submit and monitor the analysis, look for any errors that may have occurred. If you have any errors, ask the instructor for assistance. If the job completes normally, proceed onto the next step to create a modal analysis of the Space Satellite.

---

18. Read the results back into MSC.Patran

We will now read in the results back into MSC.Patran. This is done thru the Analysis form. Remember to change the Object from “Both” to “Results Entities”

◆ **Analysis**

*Action:*

**Read Output2**

*Object:*

**Result Entities**

*Method:*

**Translate**

**Select Results File...**

*Select Results File:*

**thermal\_mapping.op2** 

Note: this can be selected from the Available Files list

**OK**

**Apply**

19. Post-process the temperature results.

Before we get started, reset your view using the Toolbar icon.



**Isometric View 3**

We will now post process the results for the Structural-Thermal mapping. We will start by looking at the displacement profile for the applied loading. The expected result should be a thermal contraction since the temperature range is well below the Reference Temperature.

We will use Quick Plot to generate the deformation plot of the model.

◆ **Results**

*Action:*

**Create**

*Object:*

**Quick Plot**

*Select Result Case(s)*

**Thermal Structural,  
Static Subcase**

*Select Fringe Result*

**Displacement, Translations**

*Select Deformation Result*

**Displacement, Translations**

**Apply**

Change the fringe display click on the Fringe Attributes icon in the results form.



### Fringe Attributes

We will now change many of the Fringe Attributes to see their affect on the results display.

*Scale Factor*

*Fringe Edges:* **Black** 

*Display:*

**Apply**

It should be noted that the deformations are scaled relative to the model size. The actual deformation is quite small. Your model should look like the figure below.

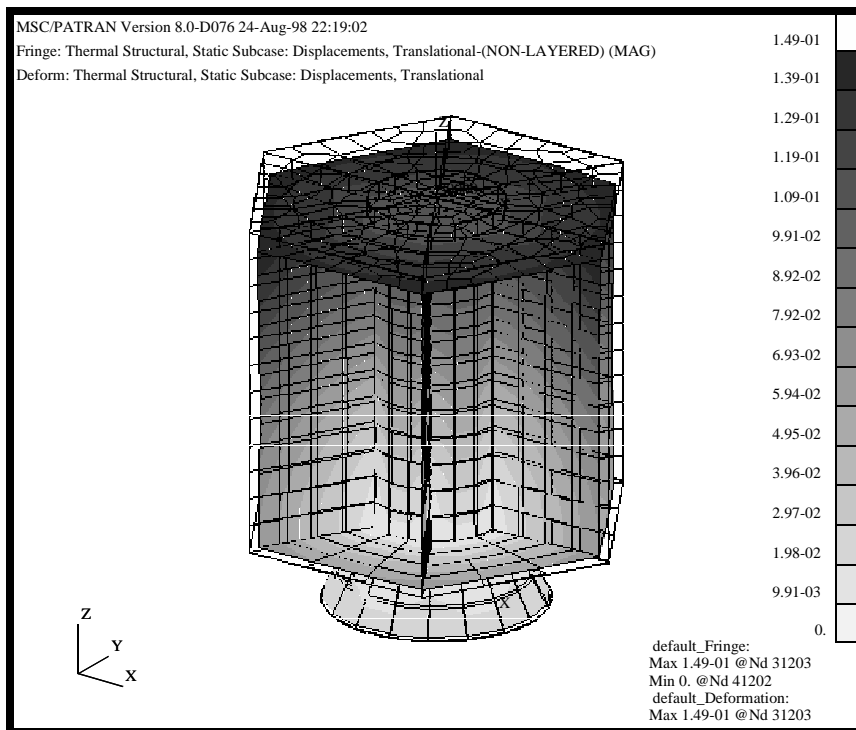

---

**Close the  
Database  
and Quit  
MSC.Patran**

20. To complete this exercise, you will close the database.

**File/Quit**

This will exit MSC.Patran and close your file. It should be noted that all changes made to the database are automatically saved and there is no need to perform a save operation.