

WORKSHOP 21

Post-Processing of Time-Dependent Results

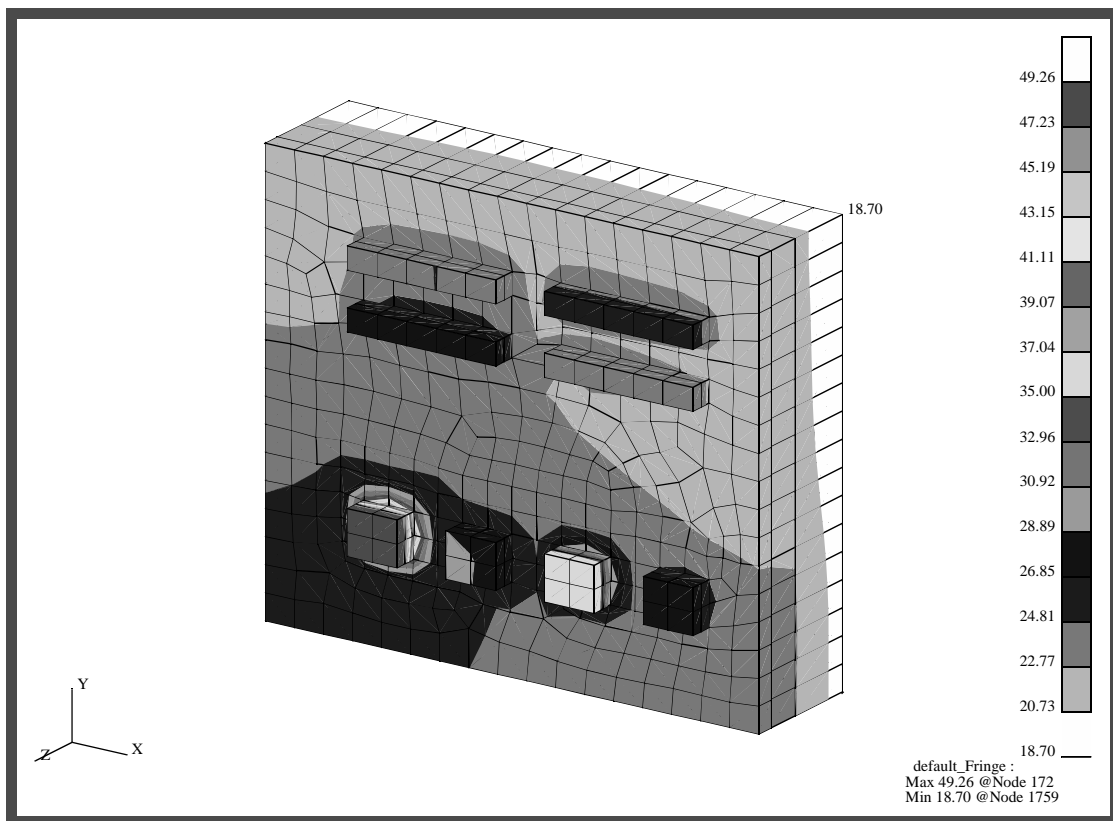

Objectives:

- Examine the results of a transient thermal analysis.
- Create Fringe and X-Y Plots.

Model Description:

In this exercise you will examine the analysis results of the microcircuit model by rendering a variety of plots of the model. You will perform a transient animation. The model was analyzed using MSC.Thermal.

Suggested Exercise Steps:

- Create a new database named **microcircuit.db**.
- Change the *Tolerance* to **Default** and the *Analysis Code* to **MSC/THERMAL**.
- Import the neutral file **microcircuit.out**. Change the model view to an isometric view, set the render style to Hidden Line, and turn off all the entity labels.
- Read into the Microcircuit database the following five MSC.Thermal result files, **nr1.nrf.01**, **nr2.nrf.01**, **nr3.nrf.01**, **nr4.nrf.01** and **nr5.nrf.01**.
- Create Fringe Plots of the Temperature values for all the imported result files.
- Create the Spectrum range, **range_1**, where the range's maximum and minimum values are **62** and **18**, respectively. Create the Fringe plots of the Temperature values using the Range_1 result range.
- Create an XY-Plot of Temperature versus Time for three Node point locations.
- Modify the XY-Plot by changing the Legend size and location so the curve titles will lie inside the Legend border. Change the Legend Title to **Temperature versus Load Case Index**.

Exercise Procedure:

1. Create a new database and name it **microcircuit**.

File/New...

New Database Name

microcircuit

OK

The viewport (Patran's graphics window) will appear along with a *New Model Preference* form. The *New Model Preference* sets all the code specific forms and options inside MSC.Patran.

In the *New Model Preference* form set the *Analysis Code* to **MSC/THERMAL**.

Tolerance: **◆ Default**

Analysis Code: **MSC/THERMAL**

Analysis Type: **Thermal**

OK

2. Import the neutral file **microcircuit.out**. Change the model view to an isometric view, set the render style to Hidden Line, and turn off all the entity labels.

First, import the neutral file.

File/Import...

Object: **Model**

Source: **Neutral**

Neutral Files: **microcircuit.out**

Apply

A confirmation window will appear. MSC.Patran echoes the title line of the selected file and queries if this is the correct file. Click **Yes**.

Yes

A message will appear asking if neutral file should be committed to PATRAN3 database. Click **Yes**.

Yes

Change the view and display by using the following toolbar icons:



Iso 1 View



Hidden Line

Your model should look like the one shown below.

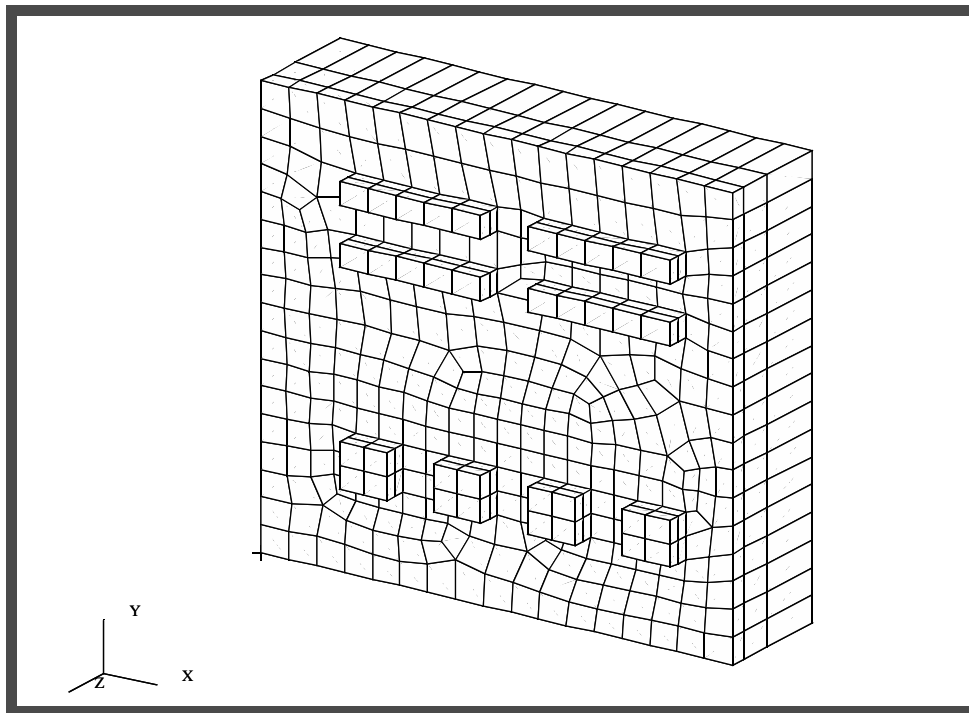

3. Read into the microcircuit database the following five MSC.Thermal result files:
nr1.nrf.01, nr2.nrf.01,
nr3.nrf.01, nr4.nrf.01
 and **nr5.nrf.01**.

◆ **Analysis**

Action:

Read Result

Object:

Result Entities

Select Results File...

Filter:

/*.nrf.*

Filter

Available Files:

nr1.nrf.01

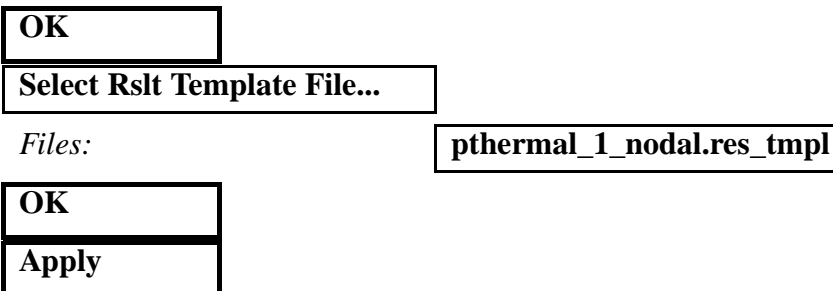
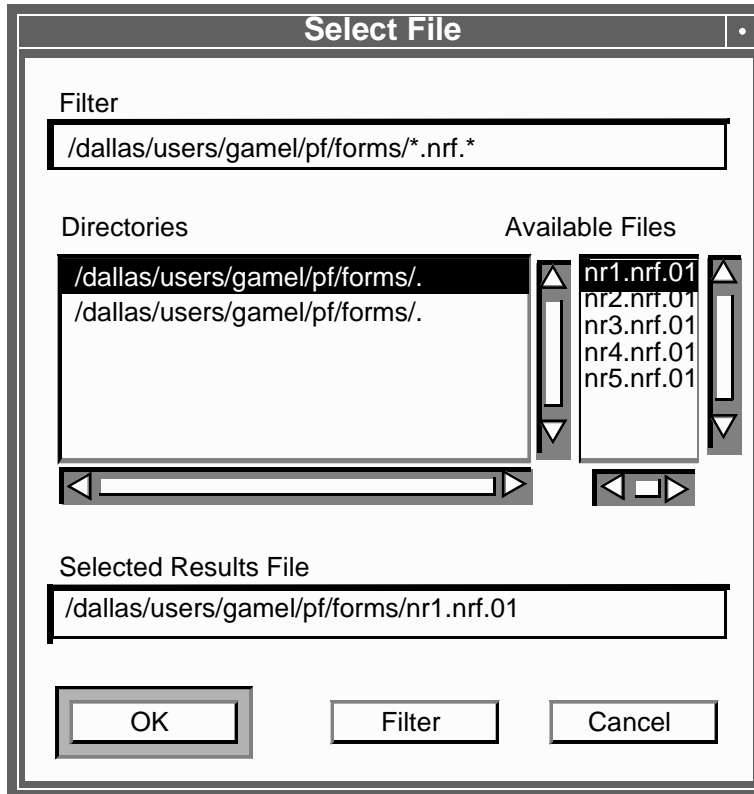

Perform this operation for the remaining four remaining results files:
nr2.nrf.01, **nr3.nrf.01**,
nr4.nrf.01 and **nr5.nrf.01**.

Note: You will only have to select the new result file and not the template file since MSC.Patran will use the previous template.

4. Create Fringe Plots of the Temperature values for all the imported result files.

Results of a transient analysis are stored as separate result cases for each time step. For example, if a transient run contains 1000 steps the MSC.Patran database will contain 1000 result cases.

You will create a Fringe plot of the Temperature values for each of the time steps.

◆ Results

Action:

Create

Object:

Fringe

Select Result Case(s)...

Select All Result Cases

Select Fringe Result...

Temperature

5. Click on the Animation Options.



Animation Method:

Global Variable

Select Global Variable:

Load Case Index

Number of Frames:

5

Interpolation:

None

6. Click on the Select Results.

**■ Animate****Apply**

When done viewing animation, stop animation and deselect the animation button.

□ Animate

Slow animation if necessary. Stop animation when ready. Check off the animation button to disable animation. The model should look similar to the one shown in the figure below.

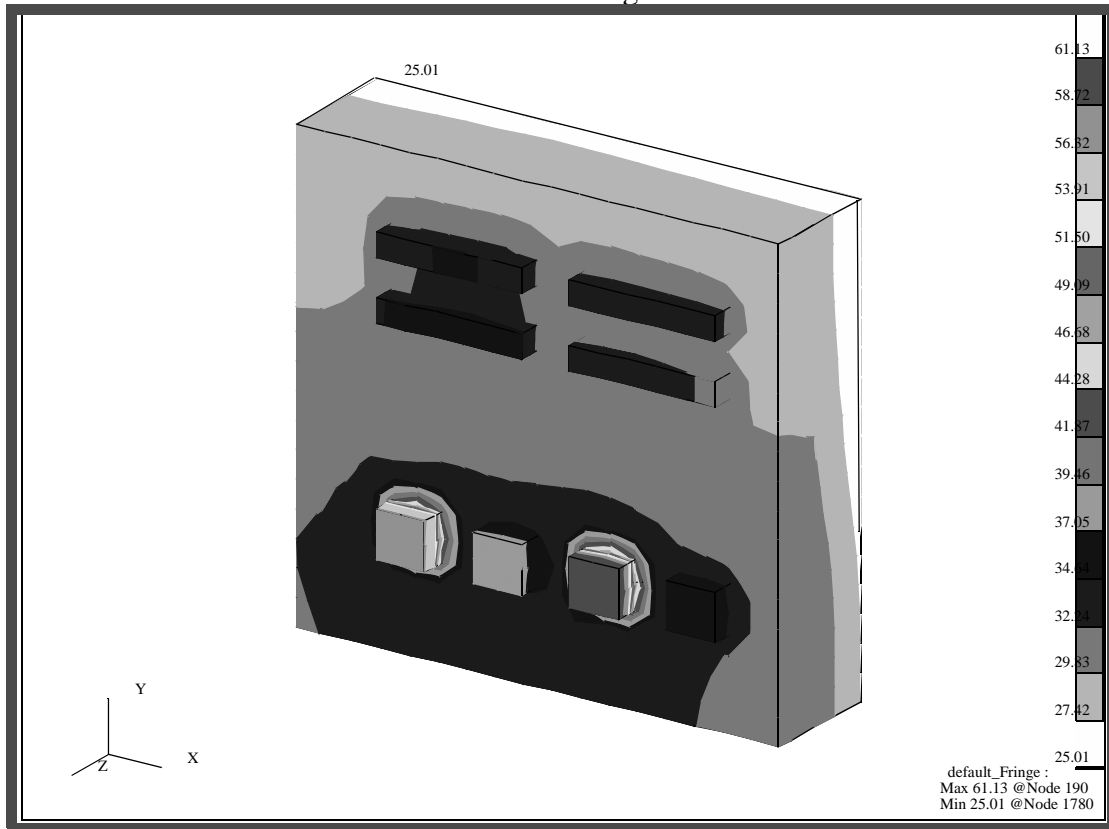

7. Click on the Display Attributes button.



8. Create the Spectrum range, **range_1**, where the range's maximum and minimum values are **62** and **18**, respectively. Create Fringe plots of the Temperature values once again using **range_1**.

<input type="button" value="Range..."/>	
<input type="button" value="Define Range..."/>	
<input type="button" value="Create..."/>	
<i>New Range Name</i>	<input type="text" value="range_1"/>
<input type="button" value="OK"/>	
<i>Start</i>	<input type="text" value="62"/>
<i>End</i>	<input type="text" value="18"/>

Calculate
Apply
Assign Target Range to Viewport
Cancel
<i>Set Range</i>
range_1
<input checked="" type="checkbox"/> Post Range to Viewport
OK

9. Create an XY-Plot of temperature versus time for three node point locations.

MSC.Patran allows you to plot transient results in the form of **XY plots**. In these plots the X-axis is either time or frequency, and the Y-axis is a dependent variable such as temperature. Create one by doing the following:

<i>Action:</i>	Create
<i>Object:</i>	Graph
<i>Method:</i>	Y vs X
<i>Select Result Case(s)...</i>	select all cases
<i>Y:</i>	Result
<i>Select Y Result:</i>	Temperature
<i>X:</i>	Global Variable
<i>Variable:</i>	Load Case Index

10. Click on the Target Entities button.



<i>Target Entity:</i>	Nodes
<i>Node IDs</i>	see picture below

Select the three nodes shown in the figure below. The selected nodes' ID's are 319, 199 and 1716.

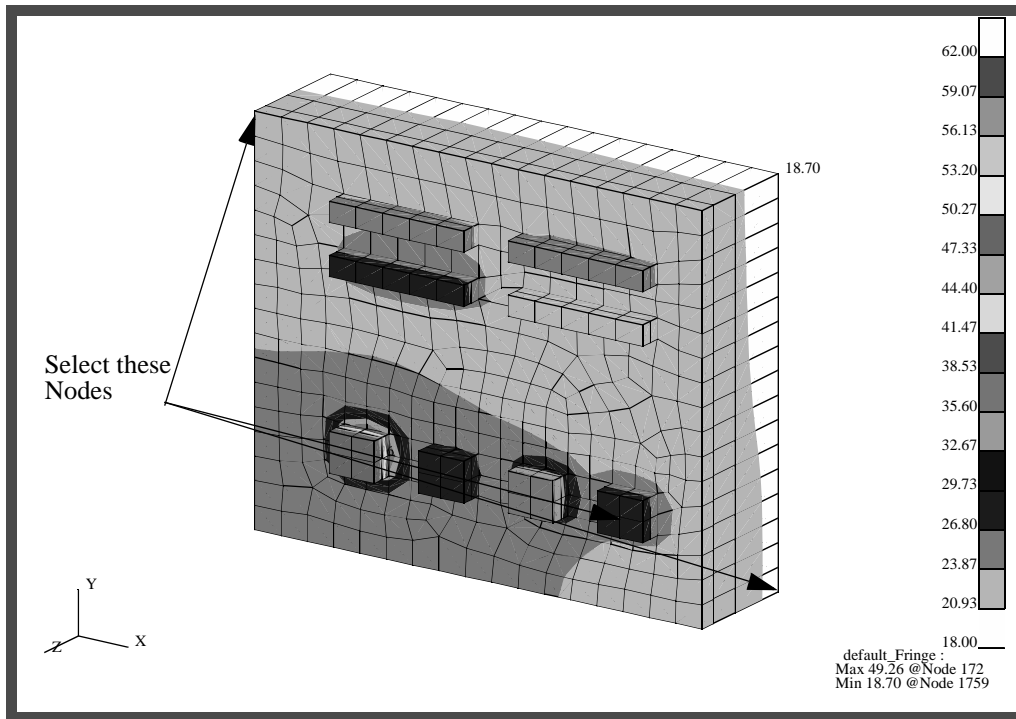

Apply

Your XY-Plots should look like the ones shown below.

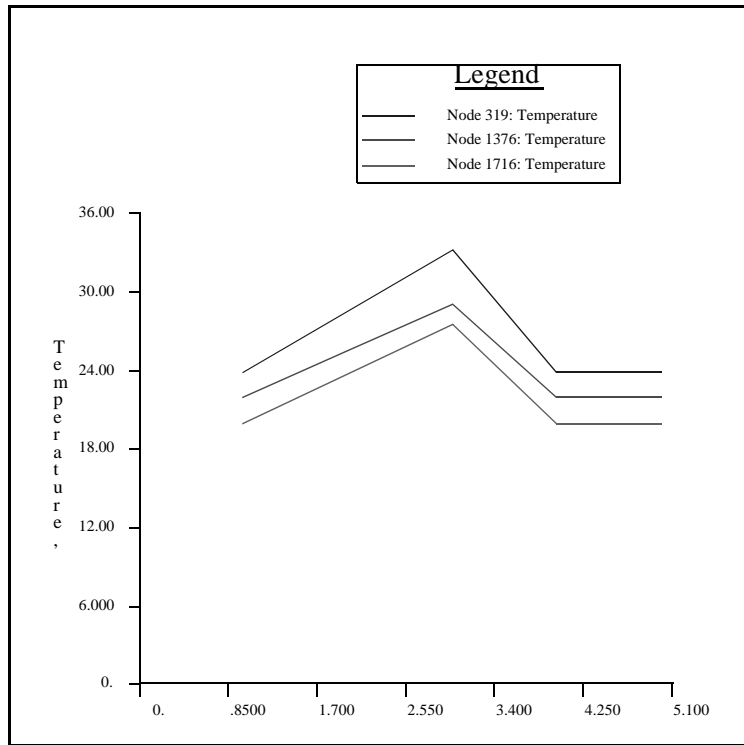

The curves become a part of your database.

- Change the x-axis scale so the numbers shown is the Load Case Number.

◆ **XY Plot**

Action:

Modify

Axis:

Axis

Scale...

Number of Primary Tick Marks:

6

Apply

Cancel

-
12. Modify the XY-Plot by changing the legend size and location so the curve titles will lie inside the legend border. Change the legend title to **Temperature versus Load Case Index**.

◆ **XY Plot**

Action:

Modify

Object:

Legend...

X Location (%)

47

Y Location (%)

13

Text

Temperature versus Load Case Index

Apply

Cancel

The new XY-Plot is shown below

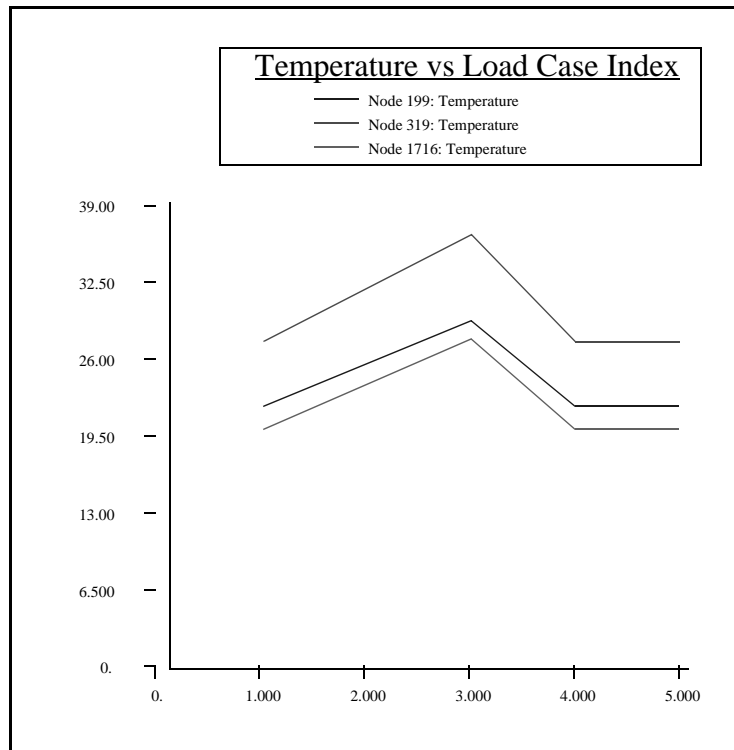

The XY Window and all its attributes are stored in the database.

13. Unpost the XY Window.

Action:

Post

Object:

XY Window...

Post/Unpost XY Windows

deselect window by <ctrl>
clicking on **Results Graph**

Apply

The XY Window should disappear from the screen. In future should you wish to re-display this XY Window, you would simply re-post it. No need to read in template and XY data files, everything is stored.

When done, close the database.

File/Quit...

