

WORKSHOP 22

Importing a PATRAN 2.5 Model into P3

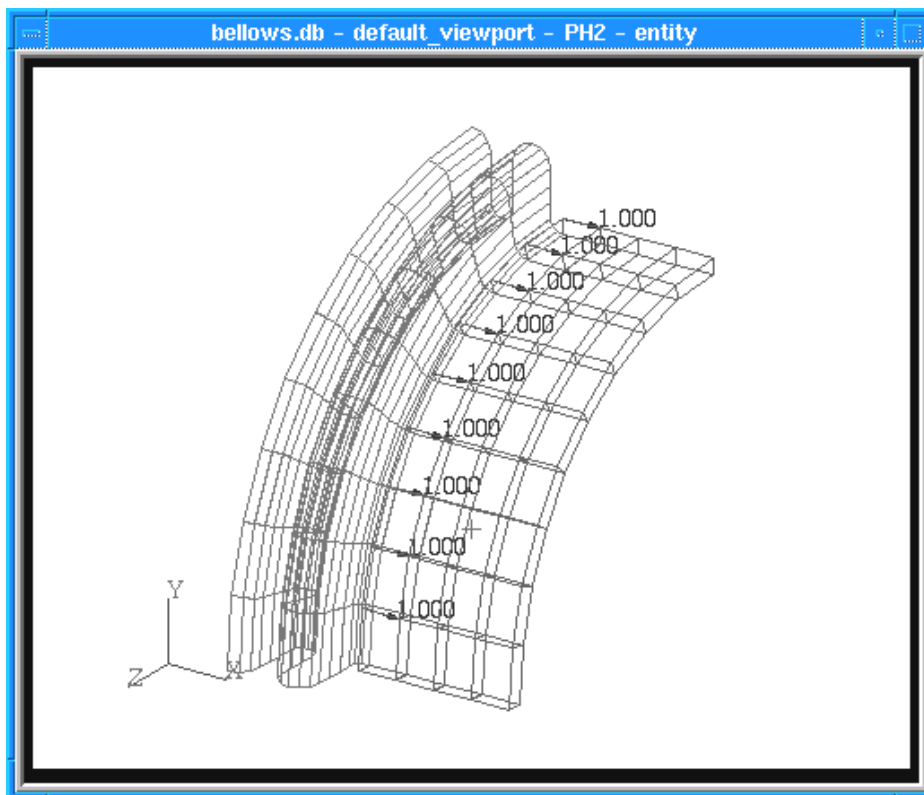

Objectives:

- Read a PATRAN 2.5 neutral file into P3.
- Import PATRAN 2.5 result files into your P3 database.
- Work with multiple load cases.

Model Description:

In this Exercise we will read in a neutral file containing a model of a bellows expansion joint. The neutral file contains Phase I and Phase II information, as well as GFEG and CFEG tables, two named components: PH1 and PH2, a pressure load, and 3 displacement sets. After verifying input of the model and viewing the various loading conditions, we will import MSC.Patran 2.5 formatted results files.

Suggested Exercise Steps:

- Create a new database with analysis code preference of ABAQUS and name it **bellows.db**.
- Read in the neutral file **bellows.out**.
- Post only the group named **PH2** and make it current.
- Create Load Cases to correspond to analysis conditions of:
 - Symmetry conditions (Displacement set 1000) plus a pressure load (Pressure set 100),
 - Enforced displacement in the global y-direction (Displacement set 2000), and
 - Enforced displacement in the axial direction (Displacement set 3000).
- Plot markers to verify loads and boundary conditions.
- Inspect element and material properties.
- Import PATRAN 2.5 displacement result files
bellows_stp1i1.dis.1,
bellows_stp2i1.dis.1,
bellows_stp3i1.dis.1.
- View the imported results.

Exercise Procedure:

1. Create a new database. Name it **bellows**.

Type **p3** in your xterm. The *Main Window* and *Command Window* will appear.

File/New...

New Database Name

bellows

OK

The viewport (Patran's graphics window) will appear along with a *New Model Preference* form. The *New Model Preference* sets all the code specific forms and options inside MSC.Patran.

In the *New Model Preference* form set the *Analysis Code* to **ABAQUS**.

Tolerance:

◆ **Default**

Analysis Code:

MSC/ABAQUS

Analysis Type:

Structural

OK

2. Read in the neutral file bellows.out.

Prior to reading in the neutral file, we'll define the display attributes we want. Use the following toolbar icons:



Iso 1 View



Display lines

File/Import...

File Name:

bellows.out

Apply

Recall that in PATRAN 2.5 element properties were code specific and the 2.5 neutral file records for element properties were not directly mapped to any particular property name. Therefore we will check all properties created for our property sets as part of this exercise.

Your model should appear as shown below.

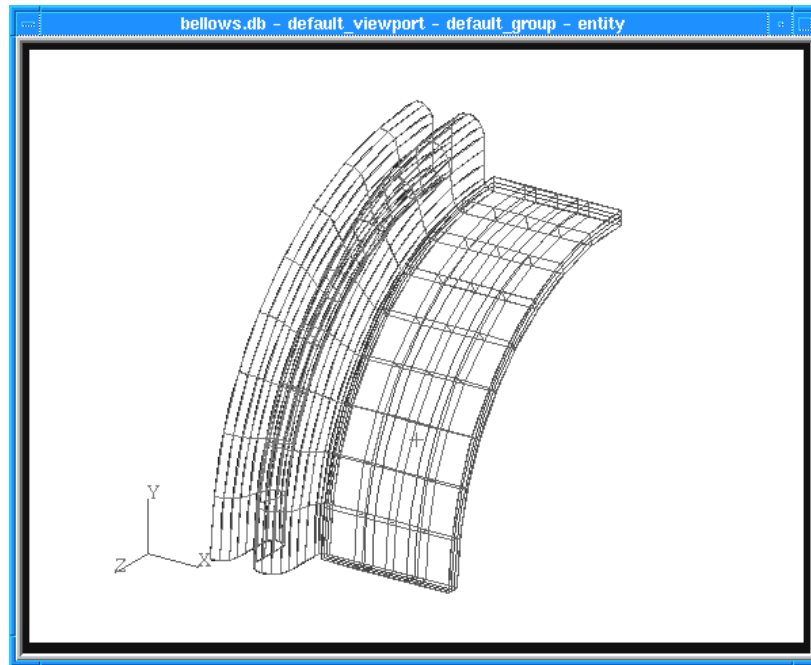

3. Post only the group named **PH2** and make it current.

To check which groups have been created, do the following:

Group/Post...

The groups in your model are: default_group, and named components PH1 and PH2.

Select Groups to Post:

PH2

Apply

Cancel

4. Create three load cases: one for symmetry, one for enforced y-displacement, and one for enforced axial displacement.

The first load case corresponds to all displacements of set 1000 and pressures of set 100.

◆ **Load Cases**

Action:

Create

Load Case Name

step_1

Description

enter the text shown below

Description: **Symmetry conditions in the circumferential direction, symmetry conditions in axial direction on free edge of shell elements, translational axial constraint on free face of solid elements, internal pressure of 55 psi**

Assign/Prioritize Load/BCs

You will select the *Load BC's* to add to the spreadsheet until all of the **DISPL.1000** and **PRESS.100** appear as on the form below.

Assign/Prioritize Load/BCs

Loads/BCs Selection

Select Individual Loads/BCs

- Displ_ DISPL.3000.0.d13456
- Displ_ DISPL.3000.0.d156
- Displ_ DISPL.3000.0.d246
- Displ_ DISPL.3000.0.d345
- Press_ PRESS.100.1
- Press_ PRESS.100.2

Select Loads/BCs from Existing Load Cases

- Default
- Load_Case.100
- Load_Case.1000
- Load_Case.2000
- Load_Case.3000

Additional Loads/BCs Controls ...

Assigned Loads/BCs

Assigned Loads/BCs	Load/BC Type		Sort By Priority
	Type	Scale Factor	
DISPL.1000.0.d1	Displacement	1.	Add
DISPL.1000.0.d12456	Displacement	1.	Add
DISPL.1000.0.d1246	Displacement	1.	Add
DISPL.1000.0.d1345	Displacement	1.	Add
DISPL.1000.0.d13456	Displacement	1.	Add
DISPL.1000.0.d156	Displacement	1.	Add
DISPL.1000.0.d246	Displacement	1.	Add
DISPL.1000.0.d345	Displacement	1.	Add
PRESS.100.1	Pressure	1.	Add
PRESS.100.2	Pressure	1.	Add

Remove Selected Rows Remove All Rows Undo Spreadsheet

OK Cancel Reset

Note: You can use click and drag to highlight the LBC's, but be very careful not to select any of the LBC's more than once. Each time you select it will increase the scale factor by the magnitude in the Selection Multiplier. If you accidentally select a LBC more than once simply change the LBC Scaling Mode to Overwrite and reselect. When your Assign/Prioritize Load/BC's form looks like the one on the previous page you may proceed.

OK
Apply

To view the Load/BC's you just prioritized go to **Load/BC's** on the main form.

◆ **Load/BC's**

Action:

Plot Markers

Current Load Case:

step_1

Assigned Load/BC Sets:

hold down shift to select only the displacements
--

Select Groups:

PH2

Apply

Your model should now appear as shown below:

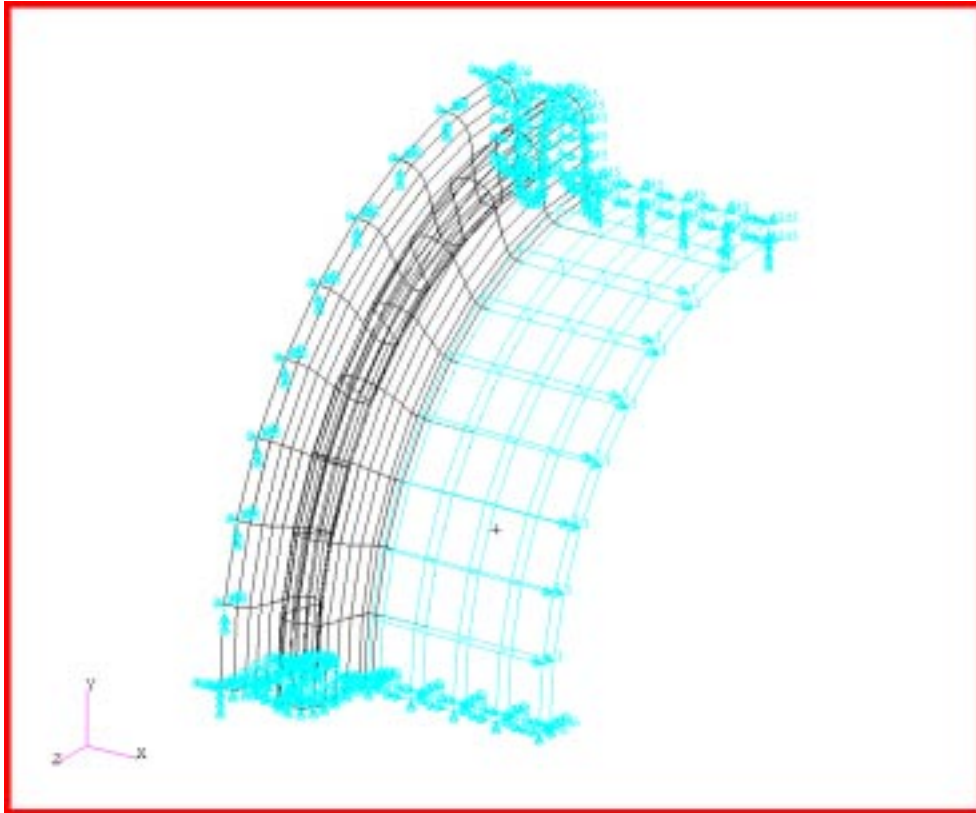

The second load case corresponds to all displacements of set 2000. Be sure to deselect all the LBC's you picked in step 1.

◆ **Load Cases**

Action:

Create

Load Case Name

step_2

Description

enter the text shown below

Description: **Enforced displacement of 0.5 inches in the global y-direction applied to every point on solid elements**

Assign/Prioritize Load/BCs

You will select the *Load BC's* to add to the spreadsheet until all of the **DISPL.2000** appear as on the form below.

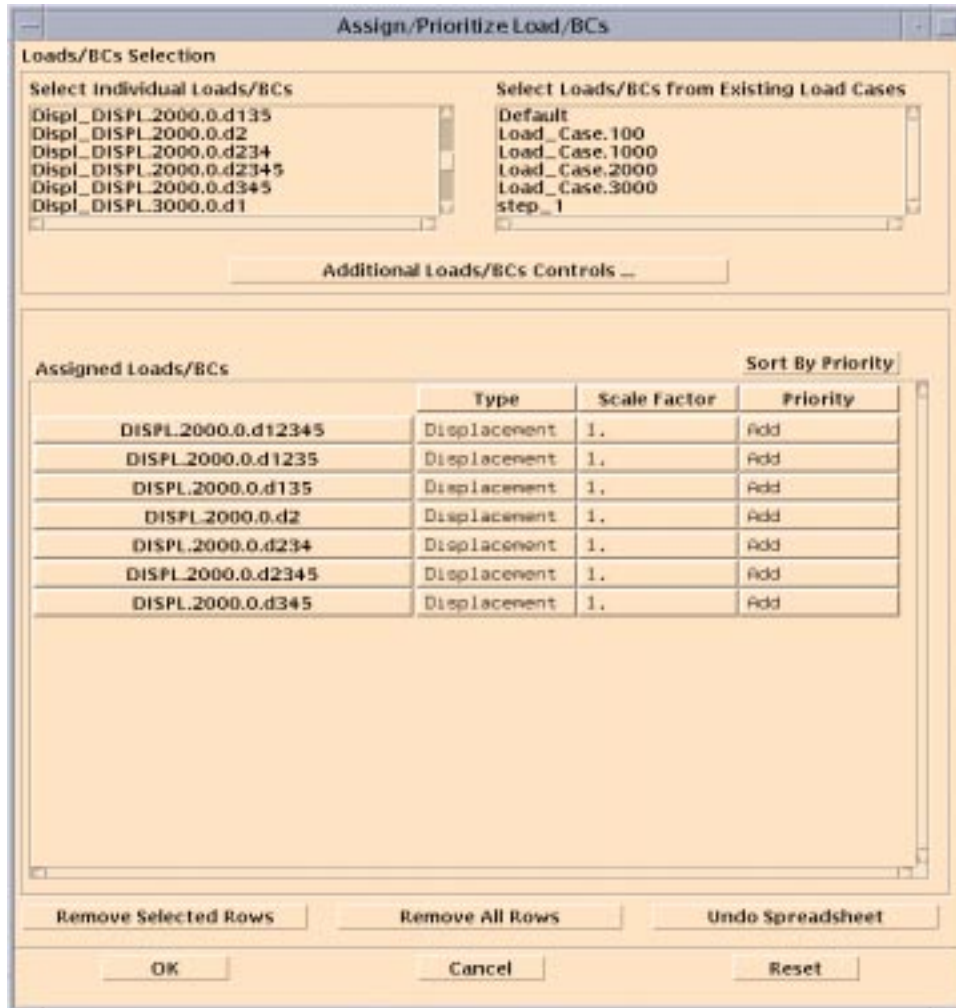

Ok
Apply

To view the any combination of the loads you have applied repeat the same step as you did for **step_1**.

The third load case corresponds to all displacements of set 3000.

Action:

Create

Load Case Name

step_3

Description

enter the text shown below

Description: **Enforced displacement of 0.5 inches in the axial direction on the free face of solid elements symmetry conditions in the circumferential direction, symmetry conditions in axial direction on free edge of shell elements**

Assign/Prioritize Load/BCs

You will select the *Load BC's to add to the spreadsheet* until all of the **DISPL.3000** appear, as shown on the form below.

The screenshot shows the 'Assign/Prioritize Load/BCs' dialog box. It has two main sections for selecting loads/BCs and a table for the assigned ones.

Loads/BCs Selection

- Select Individual Loads/BCs:** Displ_DISP.L3000.0.d13456, Displ_DISP.L3000.0.d156, Displ_DISP.L3000.0.d246, Displ_DISP.L3000.0.d345, Press_PRESS.100.1, Press_PRESS.100.2
- Select Loads/BCs from Existing Load Cases:** Default, Load_Case.100, Load_Case.1000, Load_Case.2000, Load_Case.3000, step_1

Assigned Loads/BCs Table:

Assigned Loads/BCs	Load/BC Type		Sort By Priority
	Type	Scale Factor	
DISPL.3000.0.d1	Displacement	1.	Add
DISPL.3000.0.d12456	Displacement	1.	Add
DISPL.3000.0.d1246	Displacement	1.	Add
DISPL.3000.0.d1345	Displacement	1.	Add
DISPL.3000.0.d13456	Displacement	1.	Add
DISPL.3000.0.d156	Displacement	1.	Add
DISPL.3000.0.d246	Displacement	1.	Add
DISPL.3000.0.d345	Displacement	1.	Add

Buttons at the bottom: Remove Selected Rows, Remove All Rows, Undo Spreadsheet, OK, Cancel, Reset.

Ok**Apply**

5. Inspect the element and material properties

First check the material definitions in the model.

◆ **Materials**

Action:

Show

Existing Materials

MATRL.1

Inspect the properties that appear. Then check the second material.

Action:

Show

Existing Materials

MATRL.2**Cancel**

The displayed properties give information similar to PATRAN 2.5's PMAT,#,SHOW. In the next step you will color-code the elements based on their associated materials.

Now check the element property definitions in the model.

◆ **Properties**

Action:

Show

Select Property:

Material Name

Display Method:

Scalar Plot

Select Groups:

PH2**Apply**

Your model should appear as shown below:

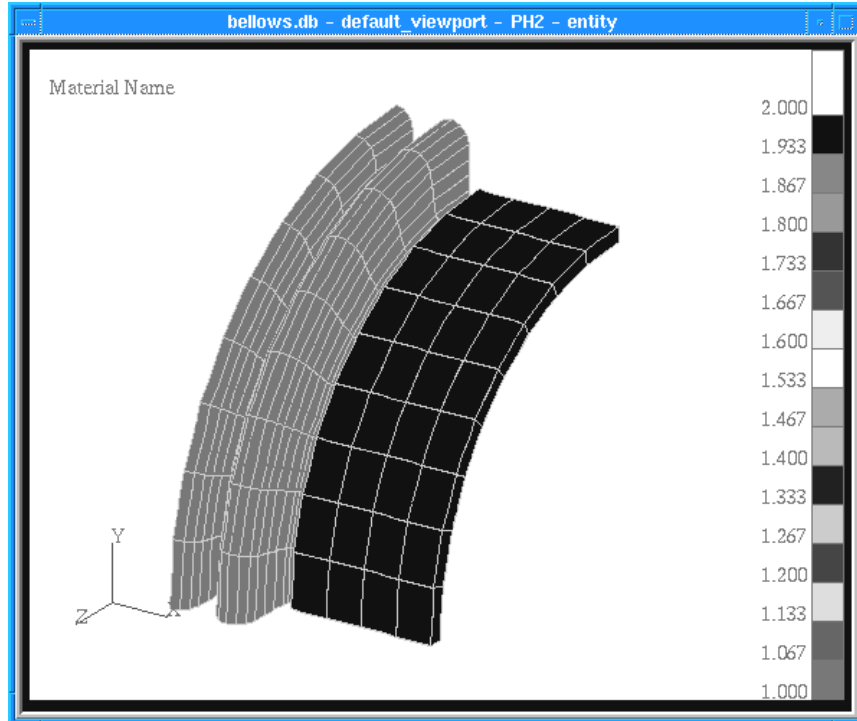

To reset the graphics before you perform the next step, click on the following main form icon:



Reset Graphics

There are beam elements in this model. To verify their orientation perform the following steps:

Action:

Show

Select Property:

Definition of XY Plane

Display Method:

Vector Plot

Select Groups:

PH2

Apply

Your model should now appear as shown below:

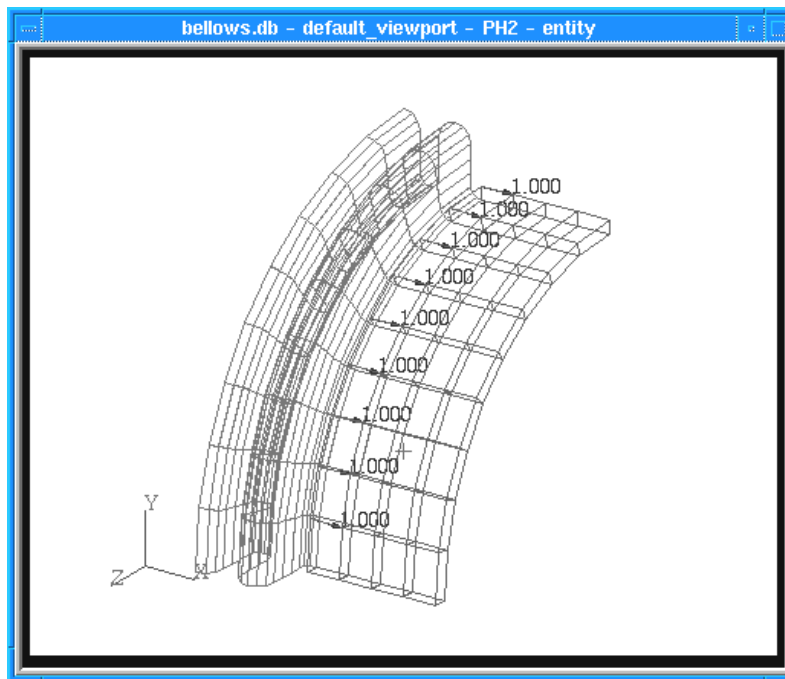

To reset the graphics before you perform the next step, click on the following main form icon:



Reset Graphics

This procedure is like a RUN,YBEAM in PATRAN 2.5. To perform the equivalent of a PROP,#,SHOW, which shows the actual value of the point used to define the beam's XY-plane, complete the following steps:

Action:

Modify

Select Prop. Set to Modify:

P_SET.100

In the *Modify Properties* from scroll down to **Definition of XY Plane**. You can now see that the beam XY-plane is defined by the plane passing through the beam longitudinal axis (default) and the vector emanating from the beam origin in the vector direction $\langle 1,0,0 \rangle$.

Highlight each remaining property set and inspect its corresponding properties.

To close the *Element Properties* from, click the following:

◆ **Properties**

6. Import the PATRAN 2.5 displacement result files:
bellows_stp1i1.dis.1,
bellows_stp2i1.dis.1,
bellows_stp3i1.dis.1

File/Import...

Object:

Results

Format:

PATRAN 2.dis...

A *Template for PATRAN 2.5 Import Results* form will be displayed.

Templates are necessary because PATRAN 3 refers to result-types by *name* whereas PATRAN 2.5 simply understands *column numbers*. The templates are the assignment map for the result-type name to the data in each column. Templates are selected to provide the mapping for the various analysis codes (in this exercise ABAQUS).

Select **abaqus_dis.res_tmpl**, and click on the **OK** button.

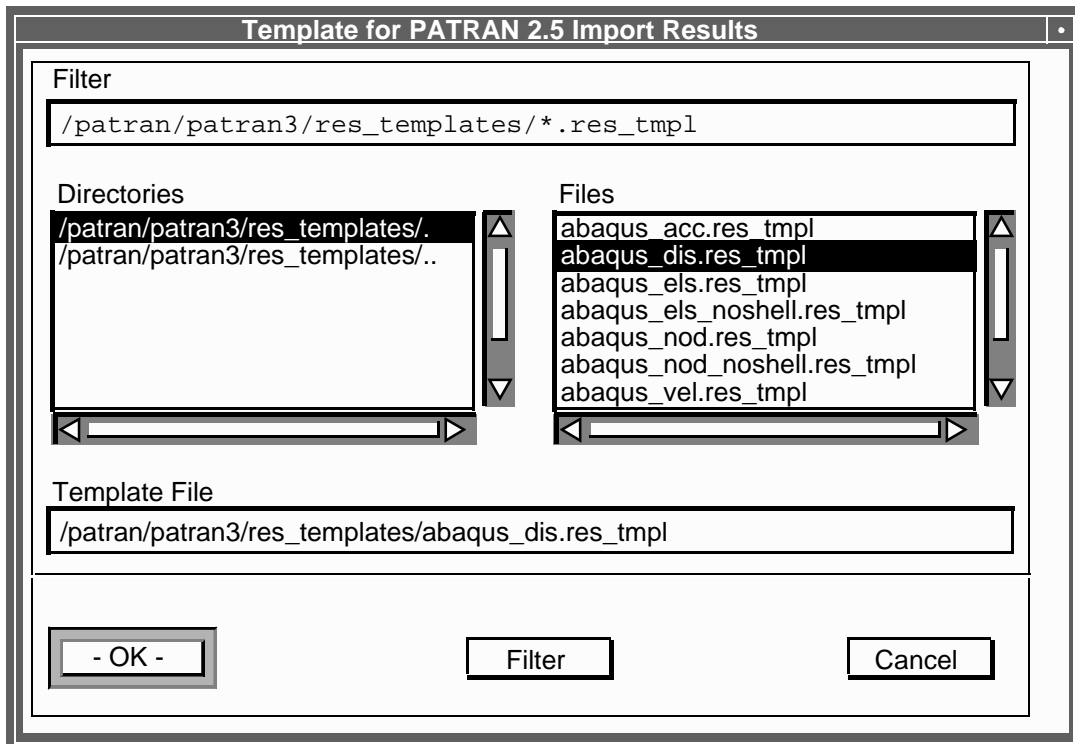

OK

On the Import form select the displacement result file, **bellows_stp1i1.dis.1**

PATRAN 2.5 .dis Files:

bellows_stp1i1.dis.1

Apply

Now that you have imported the first results file, import the second as well using the **File/Import** procedure used above.

To import results for the third and final load case, you could repeat the above procedure or you could use a technique that is frequently used with PATRAN 2.5. In PATRAN 2.5 you could recall previous commands, edit and resubmit them. By performing the following steps you can also do this in P3.

The *Main Form* contains both a *history window* and a *command line*. Previously submitted commands can be accessed by clicking on them in the history window. This copies the command to the command line, where it can be edited and submitted.

In the history window portion of the *Main Form*, click on the command used to import results **resold_import_results**. The line moves down into the command line portion of the window.

Change the “2” in **bellows_stp2i1.dis.1** to a “3”

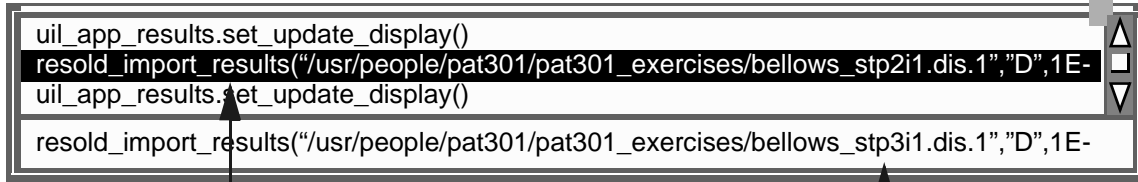

Click on this line in the history window to move a copy to the command line

Edit the filename to be bellows_stp3i1.dis.1

Hit carriage return.

You have now completed reading in displacement results for all three of our load cases. Next you will view them.

7. View the imported Results.

◆ Results

Action:

Create

Object:

Quick Plot

Select any result case, pick any deformation result, and click **Apply**.

Apply

View as many results as you wish. When done, close the database.

File/Quit...

This ends the exercise.