

Supplementary Exercise - 4

MSC.Patran Thermal Thermal Block

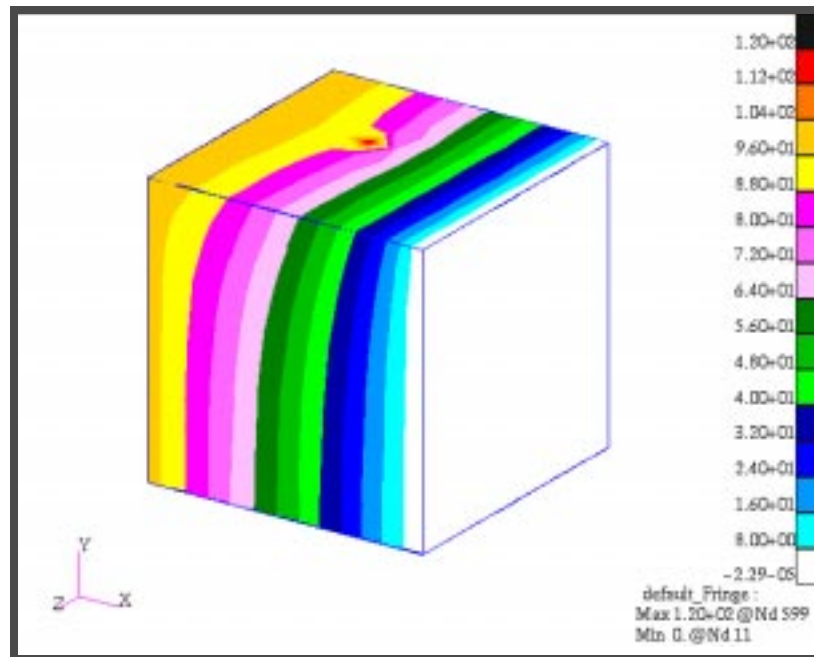

Objectives:

- Model various thermal conditions on a simple block model. This involves adding various boundary conditions:
 - Temperature
 - Heating, flux
 - Heating, nodal source
 - Radiation
 - Convection



Model Description:

In this exercise you will create a simple cube conduction thermal model and apply several thermal loads and boundary conditions. For each added boundary condition, an analysis is performed.

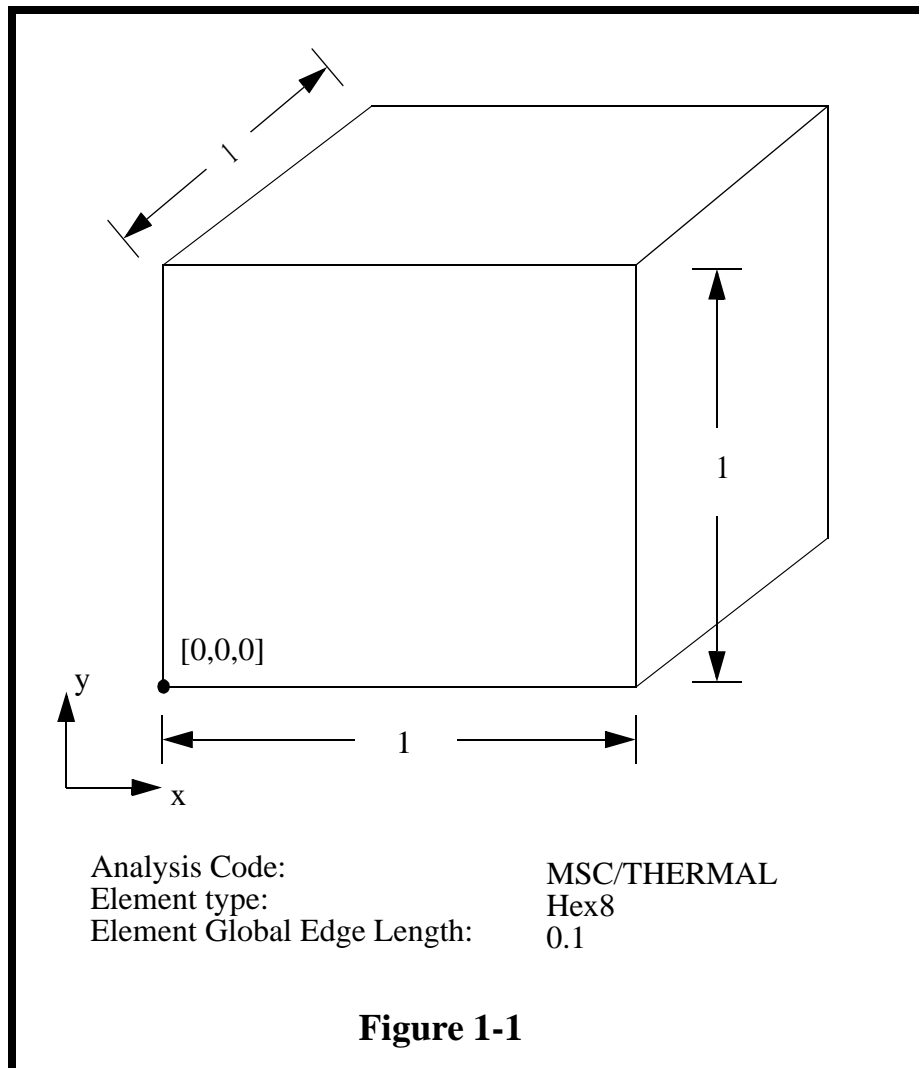

Suggested Exercise Steps:

- Create a new database named **block.db**.
- Change the Tolerance to Default and the Analysis Code to MSC/THERMAL.
- Create the geometry and finite element mesh using the information in Figure 1-1.
- Define a material named **alum**.
- Define a Property called **block**.
- Create a fixed temperature of 100°C on left face of block; use set name **fixed_left**.
- Couple the right face of the block with **Node 9999** set to 0°C; use set name **coupled_face**.
- Analyze the model and read in the results. View results using quick plot method.
- Add a constant heat flux called **constant_flux** to the model and re-analyze.
- Add a couple of heat nodal sources to the model and analyze.
- Remove the coupled nodes from the **default** load case. Change temperature of **Node 9999** to -100.0°C. Add radiation to the model between the right side of block and **Node 9999**. Analyze.
- Create a new node and add convection to model. Analyze.
- The purpose of this exercise is to demonstrate how boundary conditions can be created for a simple situation (model).

Exercise Procedure:

1. Create a new database and name it **block.db**.

File/New...

New Database Name

block

OK

2. Change the *Tolerance* to **Default** and the *Analysis Code* to **MSC/THERMAL**.

New Model Preference

Tolerance

◆ Default

Analysis Code:

MSC/THERMAL

OK

3. Create the geometry and finite element mesh.

◆ *Geometry*

Action:

Create

Object:

Solid

Method:

XYZ

Vector Coordinate List

<1,1,1>

Origin Coordinate List

[0, 0, 0]

Apply

Create a
solid

Mesh the model

Now create the mesh for the model.

◆ *Finite Elements*

<i>Action:</i>	<input type="text" value="Create"/>
<i>Object:</i>	<input type="text" value="Mesh"/>
<i>Type:</i>	<input type="text" value="Solid"/>
<i>Global Edge Length</i>	<input type="text" value="0.1"/>
<i>Mesher</i>	◆ Isomesh
<i>Element Topology</i>	<input type="text" value="Hex8"/>
<i>Solid List</i>	<input type="text" value="Solid 1"/>
<input type="text" value="Apply"/>	

Your finite element model should look like the one shown in the figure below.

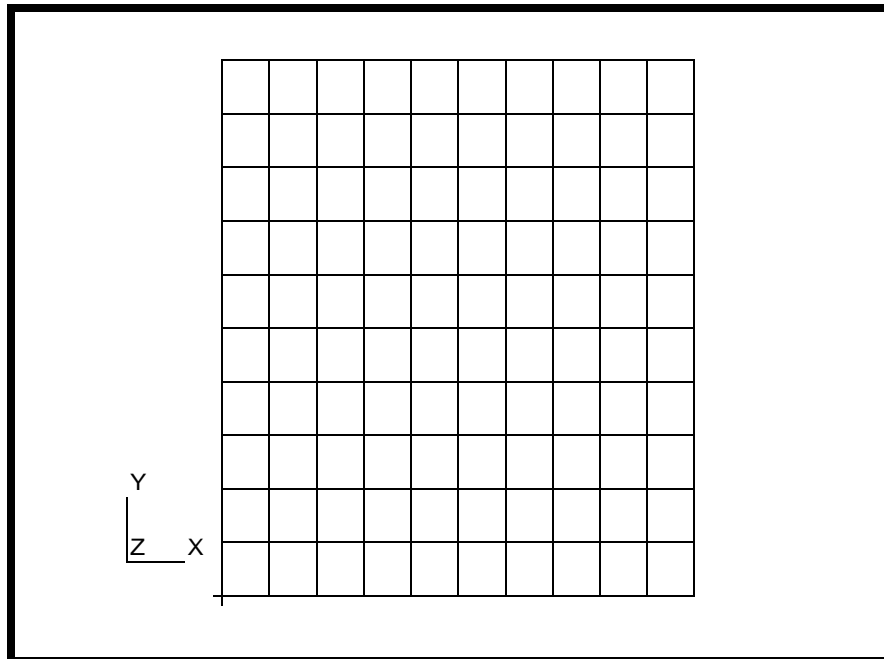

The following node to be created will be used as the coupling node for specifying the temperatures on the right side of the model.

<i>Action:</i>	<input type="text" value="Create"/>
<i>Object:</i>	<input type="text" value="Node"/>
<i>Method:</i>	<input type="text" value="Edit"/>

Node ID List

Associate with Geometry

Node Location List

4. Create a material property set for aluminum called **alum**.

Create
Material

◆ *Materials*

Action:

Object:

Method:

Material Name

Thermal Conductivity

Density

Specific Heat

5. Define solid element properties with set called **block**.

Create
Property

◆ *Properties*

Action:

Object:

Type:

Property Set Name

Material name

**Create
Loads and
BCs**

OK	
<i>Select Members</i>	Solid1
Add	
Apply	

6. Create a fixed temperature on the left face of the block model. Set the temperature there to 100°C (set name **fixed_left**). Then specify the temperature on the right face using the nodal coupling option-- couple the temperature at a single node to that of a set of nodes. The coupling node is Node 9999 and is at 0°C.

◆ *Loads/BCs*

<i>Action:</i>	Create
<i>Object:</i>	Temperature (PThermal)
<i>Type:</i>	Nodal
<i>Option:</i>	Fixed
<i>New Set Name</i>	fixed_left
Input Data...	
<i>Fixed Temperature</i>	100
OK	
Select Application Region...	

◆ *Geometry*

<i>Select Geometry Entities</i>	select left face of the solid (Solid 1.1)
Add	
OK	
Apply	

<i>Action:</i>	Create
<i>Object:</i>	Temperature (PThermal)
<i>Type:</i>	Nodal

Option:

New Set Name

Select Application Region...

◆ *FEM*

Slave Region

Select Nodes

Add

Master Region

Select Nodes

Add

OK

Apply

Set the temperature of the master region, ie. **Node 9999**.

Action:

Object:

Type:

Option:

New Set Name

Input Data...

Fixed Temperature

OK

Select Application Region...

◆ *FEM*

Select Nodes

Add

OK

Apply

7. Analyze the model

◆ *Analysis*

Action:

Object:

Method:

Calculation Temperature Scale: ◆ Celsius

Units Scale for Output Temperatures: ◆ Celsius

8. Read in the results.

Action:

Object:

Select under Directories the jobname subdirectory, e.g. /baja/users/patran.class/jobname (as seen in Jobname).

Selected Results Files:

Template File:

- In Results, use quick plot and choose temperature as your fringe result.

◆ **Results**

Action:

Create

Object:

Quick Plot

Select Result Cases:

0.000000000D +00

Select Fringe Result:

Temperature,

Apply

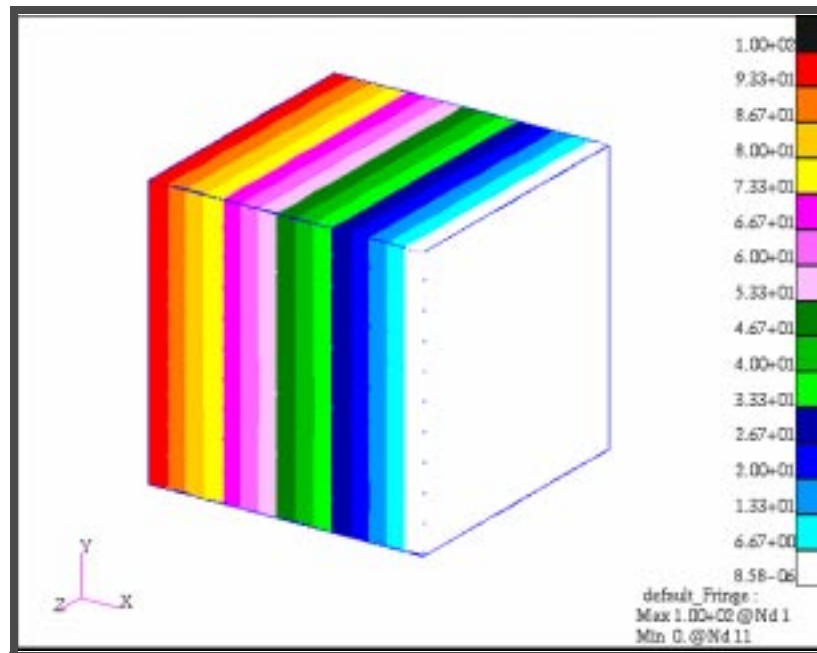

You will need to reset the graphics by using the **Reset Graphics** Icon after viewing the results.



10. Add a heat flux to the top face of the solid cube.

◆ *Loads/BCs*

<i>Action:</i>	<input type="text" value="Create"/>
<i>Object:</i>	<input type="text" value="Heating (PThermal)"/>
<i>Type:</i>	<input type="text" value="Element Uniform"/>
<i>Option:</i>	<input type="text" value="Flux, Fixed"/>
<i>New Set Name</i>	<input type="text" value="constant_flux"/>
<input type="text" value="Input Data..."/>	
<i>Fixed Heat Flux</i>	<input type="text" value="10000"/>
<input type="text" value="OK"/>	
<input type="text" value="Select Application Region..."/>	

◆ *Geometry*

<i>Select Solid Faces</i>	<input type="text" value="select top face of solid (Solid 1.4)"/>
<input type="text" value="Add"/>	
<input type="text" value="OK"/>	
<input type="text" value="Apply"/>	

11. Check the load case named **Default**, that is always used for an MSC.Thermal analysis, to see that all loads and boundary conditions are being used.

◆ *Load Cases*

<i>Action:</i>	<input type="text" value="Modify"/>
<i>Select Load case to Modify</i>	<input type="text" value="Default"/>

See the Loads/BCs that will be used for the analysis under Assigned Loads/BCs.

<input type="text" value="Cancel"/>

12. Analyze the model and view the results (newest result case). After viewing the results reset graphics.

Change the job name for this analysis.

◆ *Analysis*

Action:

Analyze

Object:

Full Model

Method:

Full Run

Job Name

block_flux

Apply

Read the results file as before, but this time select the results file, **nr0.nrf.01**, under the new job name subdirectory, **block_flux**. It is not necessary to select the results template file a second time.

The result should look like the following figure.

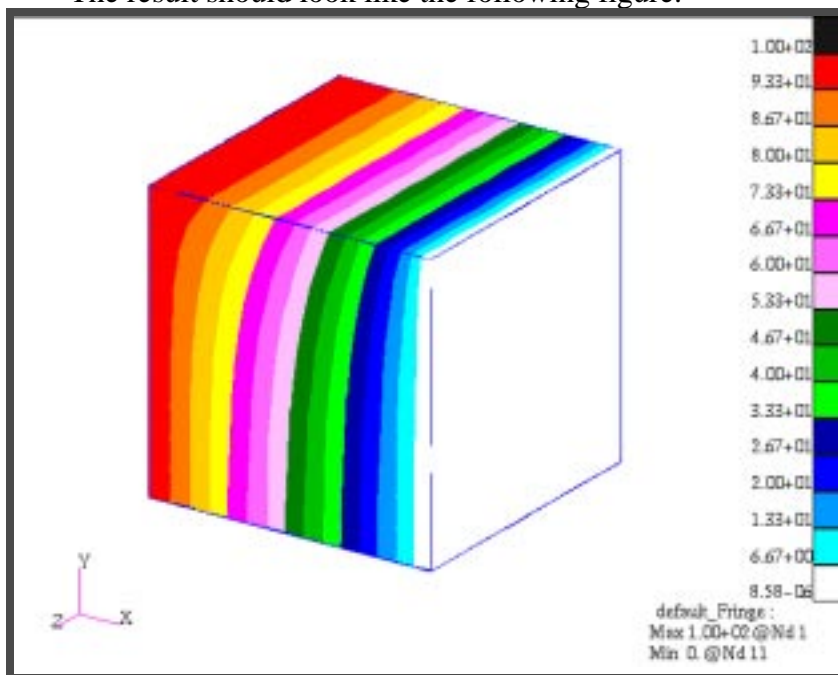

13. Create heating for nodal sources in the model.

◆ *Loads/BCs*

Action:

Create

Object:

Heating (PThermal)

Type:

Element Uniform

Option:

Template, Nodal Source

New Set Name

node_sources

Input Data...

Nodal Source

1000

OK

Select Application Region...

◆ *FEM*

Select nodes

select 2 nodes from interior

Add

OK

Apply

14. Analyze the model and view the results (newest result case). Remember to change the job name. The result will depend on which nodes are chosen for the location of the nodal sources, but will have a relationship to the following plot. After viewing results reset graphic.

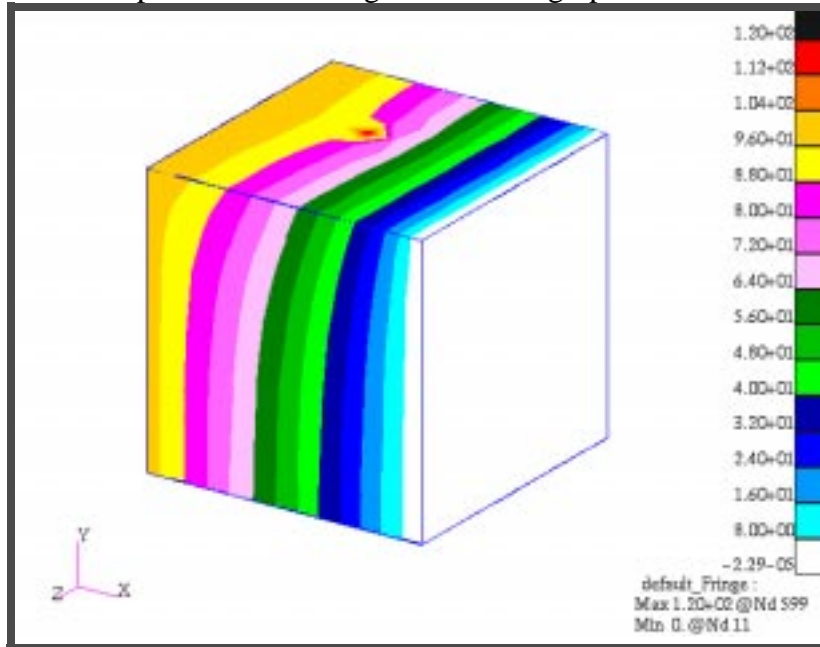

15. Add radiation to the right side of model and modify temperature of **Node 9999** to be -100.0°C. The coupled nodes should be removed from the default load case.

◆ *Load Cases*

Action:

Modify

Select Load Case To Modify:

Default

Assigned Loads/BCs:

coupled_face

Remove Selected Rows

OK

Apply

◆ *Loads/BCs*

<i>Action:</i>	<input type="text" value="Create"/>
<i>Object:</i>	<input type="text" value="Radiation (PThermal)"/>
<i>Type:</i>	<input type="text" value="Element Uniform"/>
<i>Option:</i>	<input type="text" value="Gap Radiation"/>
<i>New Set Name</i>	<input type="text" value="radiation"/>
<i>Target Element Type:</i>	<input type="text" value="3D"/>
<i>Region2:</i>	<input type="text" value="Nodal"/>
<input type="text" value="Input Data..."/>	
<i>Application Surf Emissivity</i>	<input type="text" value="0.8"/>
<i>Coupling Surf Emissivity</i>	<input type="text" value="1.0"/>
<i>Form Factor</i>	<input type="text" value="1.0"/>
<input type="text" value="OK"/>	
<input type="text" value="Select Application Region..."/>	

◆ *FEM*

<i>Coupling Method</i>	<input type="text" value="Closest Approach"/>
<i>Application Region</i>	
<i>Select 3D Element Faces</i>	<input type="text" value="select right side of block"/>
<input type="text" value="Add"/>	
<i>Companion Region</i>	
<i>Select Nodes</i>	<input type="text" value="Node 9999"/>
<input type="text" value="Add"/>	
<input type="text" value="OK"/>	
<input type="text" value="Apply"/>	

Modify the temperature of the **fixed_node** to be -100°C.

Action:	<input type="text" value="Modify"/>
Object:	<input type="text" value="Temperature (PThermal)"/>
Type:	<input type="text" value="Nodal"/>
Option:	<input type="text" value="Fixed"/>
Select Set To Modify:	<input type="text" value="fixed_node"/>
<input type="button" value="Modify Data..."/>	
Fixed Temperature	<input type="text" value="-100"/>
<input type="button" value="OK"/>	
<input type="button" value="Apply"/>	

16. Analyze the model and view the results (newest result case). Remember to change the job name. After viewing results reset graphic.

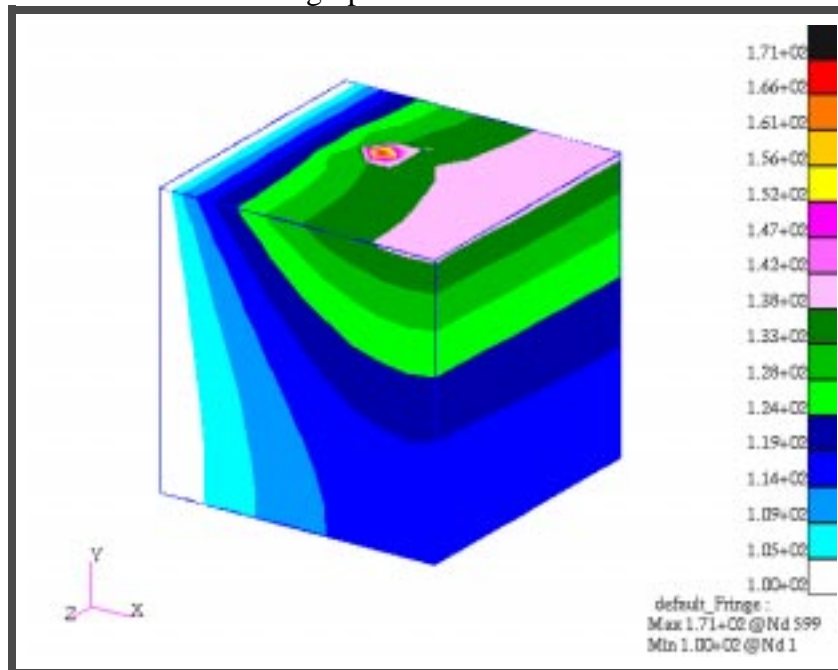

-
17. Add convection to the bottom of the model. Create a node below the bottom of model and give it a temperature of 0°C.

◆ *Finite Elements*

<i>Action:</i>	<input type="text" value="Create"/>
<i>Object:</i>	<input type="text" value="Node"/>
<i>Method:</i>	<input type="text" value="Edit"/>
<i>Node ID List</i>	<input type="text" value="20000"/>
<input type="checkbox"/> <i>Associate with Geometry</i>	
<i>Node Location List</i>	<input type="text" value="[0.5 -0.5 0.5]"/>
<input type="text" value="Apply"/>	

◆ *Loads/BCs*

<i>Action:</i>	<input type="text" value="Create"/>
<i>Object:</i>	<input type="text" value="Temperature (PThermal)"/>
<i>Type:</i>	<input type="text" value="Nodal"/>
<i>Option:</i>	<input type="text" value="Fixed"/>
<i>New Set Name</i>	<input type="text" value="conv_temp"/>
<input type="text" value="Input Data..."/>	
<i>Fixed Temperature</i>	<input type="text" value="0.0"/>
<input type="text" value="OK"/>	
<input type="text" value="Select Application Region..."/>	

◆ *FEM*

<i>Select Nodes</i>	<input type="text" value="Node 20000"/>
<input type="text" value="Add"/>	
<input type="text" value="OK"/>	
<input type="text" value="Apply"/>	

Thermal Block

Set the convection condition between the **conv_temp** and the bottom of the solid.

<i>Action:</i>	<input type="text" value="Create"/>
<i>Object:</i>	<input type="text" value="Convection (PThermal)"/>
<i>Type:</i>	<input type="text" value="Element Uniform"/>
<i>Option:</i>	<input type="text" value="Fixed Coefficient"/>
<i>New Set Name</i>	<input type="text" value="convection"/>
<i>Target Element Type:</i>	<input type="text" value="3D"/>
<i>Region2:</i>	<input type="text" value="Nodal"/>
<input type="text" value="Input Data..."/>	
<i>Convection Coefficient</i>	<input type="text" value="1000"/>
<input type="text" value="OK"/>	
<input type="text" value="Select Application Region..."/>	
◆ <i>FEM</i>	
<i>Coupling Method</i>	<input type="text" value="Closest Approach"/>
<i>Application Region</i>	
<i>Select 3D Element Faces</i>	<input type="text" value="select bottom side of block"/>
<input type="text" value="Add"/>	
<i>Coupling Region</i>	
<i>Select Nodes</i>	<input type="text" value="Node 20000"/>
<input type="text" value="Add"/>	
<input type="text" value="OK"/>	
<input type="text" value="Apply"/>	

18. Analyze the model and view the results (newest result case). Change the job name. After viewing the results reset the graphics.

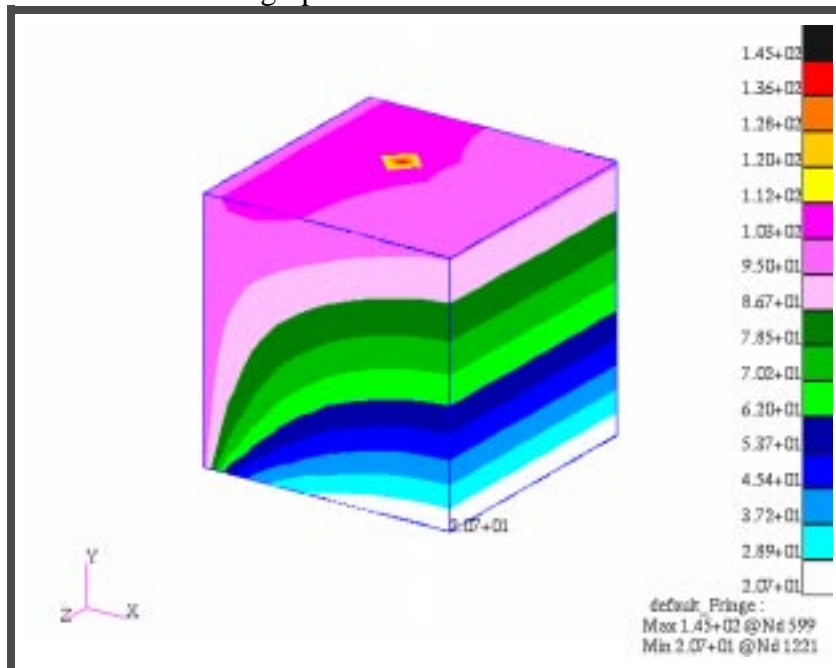

19. To complete the exercise, close the database.

File/Quit...