

LESSON 1

Keymapping PCL Functions

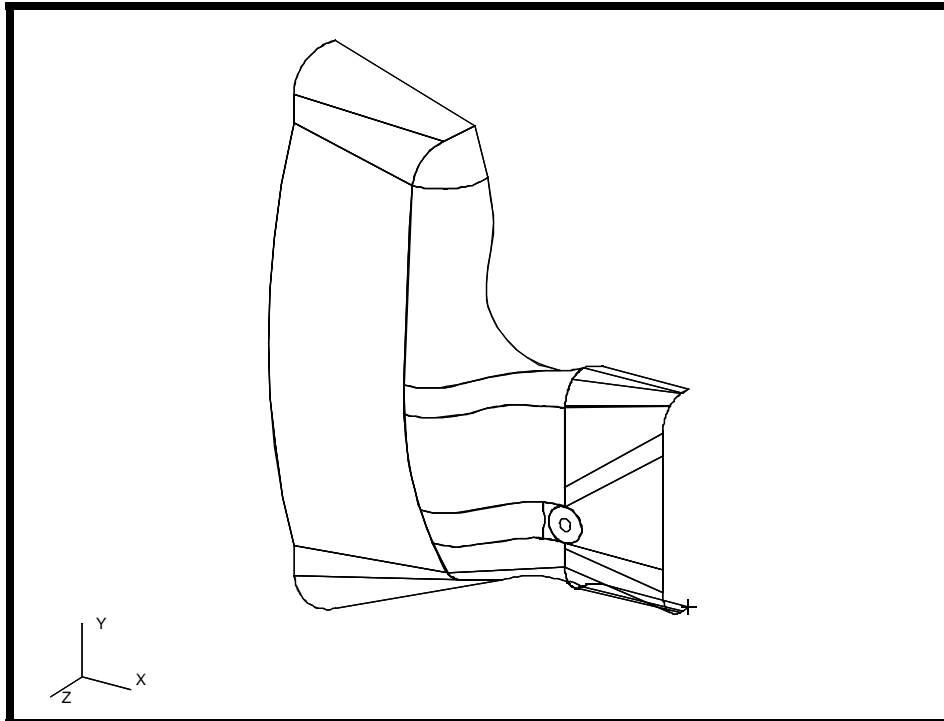

Objectives:

- Import an express neutral file
- Key Map several PATRAN commands to one key.
- Use the session file generated by PATRAN to create a PCL function.



Model Description:

In this exercise you will import an express neutral file into a Patran database. You will then perform a few display changes with the model, recording these changes in a session file. A terminal window will be opened, and (using a text editor) the recorded session file will be converted into a PCL function. The function will then be keymapped to a specific function key.

Exercise Procedure:

1. In your xterm window type **p3** to start MSC/PATRAN. Then create a new database called, **shield.db**.

File/New ...*New Database Name:***shield.db****OK**

Click **OK** in the New Model Preference form.

2. Import the graphics file.

File/Import...*Object:***model***Source:***Parasolid xmt***Express Neutral Files:***shield_v11.xmt_txt****Apply**

Look at the Import Summary form. Notice the types of geometry that were imported with this parasolid file. Click **OK** at the bottom of the form.

OK

3. Start recording a new session file by doing the following:

File/Session/Record ...*Recording File:***keymap_sample.pcl**

Apply

The next steps are going to be done in sequential order so that you may later change the journal file into a simple PCL function.

4. Change the view to Iso1 View.



Iso1 View

5. Open the Display/Geometry form and move the shrink geometry slide bar until it reads .30. This should shrink all your geometry by 30 percent. Change the point size to 5. Turn on the **Tsurf** labels..

Display/Geometry ...

Geometric Shrink:

.30

Point Size:

5

Colors and Labels:

Surface

Tsurf

Apply

Cancel

6. Change the rendering to smooth shaded using the following toolbar icon:



Smooth Shaded

7. After completing these steps go to **File/Session/Record...** and click the **Stop** button. This will end this portion of the session file.

File/Session/Record ...

Stop

Cancel

8. Now open a UNIX window or DOS command prompt and use a text editor to make the following changes to **keymap_sample.pcl.01**:

You will need to exit entirely out of PATRAN before you can edit the file in Windows NT. Delete any line that starts with a dollar sign then pound symbol (\$# - these are just comments in the PATRAN Command Language). Just before the line:

```
ga_view_aa_set( 23., -34., 0. )
```

add the line:

```
FUNCTION Set_Display_Att()
```

After the last line:

```
uil_toolbar.shaded_smooth ( )
```

enter this line:

```
END FUNCTION
```

This session file that was just edited can now be used to as a PCL function that can be executed in PATRAN.

9. Close the database and, once again, open a new database with the same name as before.

File/Close

File/New ...

New Database Name:

When prompted that a database already exists with the same name, respond that you wish to overwrite the old database.

Click **OK** in the New Model Preference form

10. In the command window of PATRAN type:

```
!!input keymap_sample.pcl.01
```

11. In the main menu of PATRAN go into **Preferences/Key Map...** and set up the **F6** key to utilize the recently made PCL function.

Preferences/Key Map ...

■ F Key

To Action:

CallPCL

■ **Customize**

Map String:

None<Key>F6: CallPCL
("Set_Display_Att")

Apply

Note: The only thing that needs to be typed into the databox is the name of the function: "**Set_Display_Att**", and this needs to be entered inside the parentheses.

Close the *Keymap Preferences* form.

Close

12. Import the part file just as before.

File/Import...

Object:

model

Source:

Parasolid xmt

Express Neutral Files:

shield_v11.xmt_txt

Apply

Look at the Import Summary form. Notice the types of geometry that were imported with this parasolid file. Click **OK** at the bottom of the form.

OK

13. Click on the default viewport to make it active (the keymapping will not work if the viewport is not the active screen) Press the **F6** key when the part file is done loading. The surfaces of the part should now shrink and appear like the following:

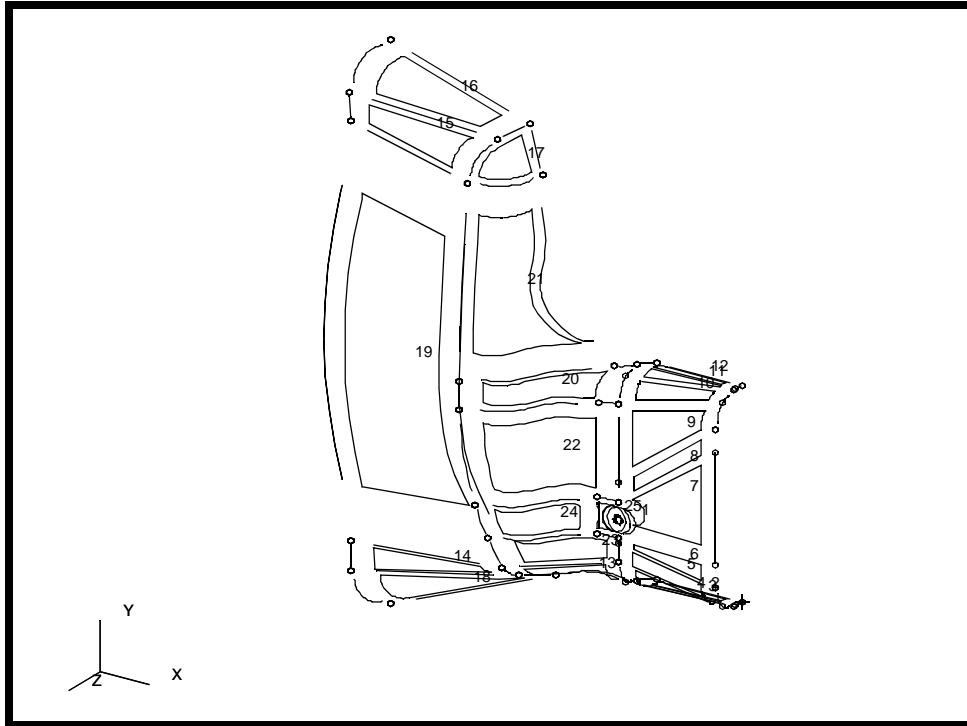

14. Make the keymapped function a permanent feature of all your PATRAN sessions.

Open a UNIX window. Then, look at the file called **.Patran.EventMaps**. Notice that the last line contains the keymap string that you input from the *Keymap Preferences* form. Unfortunately, if you were to restart PATRAN and try to use the **F6** key again, nothing would happen because the PCL function was not loaded. Instead of manually inputting the function every time you start PATRAN, there is an easier way to make the function available for every session.

Compile the PCL function into a library by inputting the following command in the PATRAN command window:

!!compile keymap_sample.pcl.01 keymap

Use a text editor to create a file by the name of **p3epilog.pcl** which contains the following line:

!!library keymap.plb

When done, quit PATRAN and restart it. Then, once again, create a new database called **shield.db**.

File/New ...

New Database Name:

shield.db

OK

When prompted that a database already exists with the same name, respond that you wish to overwrite the old database.

Yes

Click **OK** in the New Model Preference form.

Import the Express Neutral file one last time.

File/Import...

Object:

model

Source:

Parasolid xmt

Express Neutral Files:

shield_v11.xmt_txt

Apply

Once again, close the warning and import summary.

OK

Push **F6**. Notice that PATRAN executes the PCL function.

This ends the exercise.