

# LESSON 6

## *Geometry Construction*

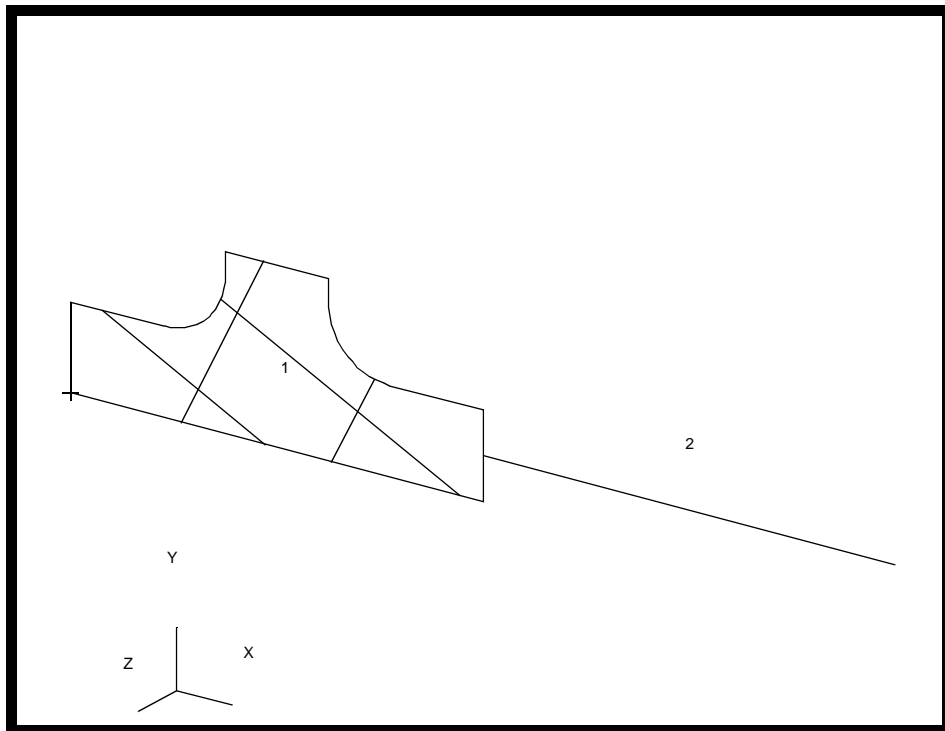

### **Objectives:**

- Create a fillet.
- Build a trimmed surface model.



## Model Description:

In this lesson you will create the required 2-D geometry for a 3D model. You will construct geometry that you will use to form a chain that represents the outer boundary (loop) of the trimmed surface. In a later exercise you will define its finite element mesh, and create multi-point constraints. Shown below is the cross section of the 3-D model.

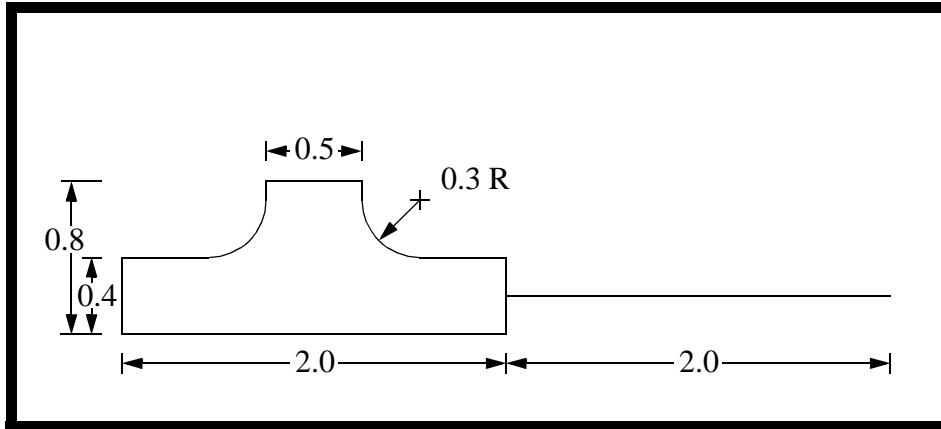

FIGURE 1.

## Suggested Exercise Steps:

- Open a new database called **mpc.db** with a maximum model dimension of 4 units and P3/FEA as the analysis code.
- Use straight lines and two 0.3 unit fillets to create the geometry shown above.
- Chain together the lines in your model to create one continuous curve.
- Use this chained curve to define the outer loops of a planar-trimmed surface.
- Display the normal direction of the surface.
- Create a cylindrical coordinate frame at -6 units in the y direction, having the local z-direction aligned with the global x-direction.

## Files:

All the files used in this exercise are listed below. Each listing includes the file, where it originated, its format (text/binary) and summary information as to how it relates to this exercise.

File	Supplied/Created	Description
mpc.db	Created	This is a MSC/PATRAN database (binary) that is created in Exercise 2. The geometry for the model is created in this exercise. The mesh for the model will be generated in Exercise 6. Finally, multi-point constraints will be created in Exercise 7.

## Exercise Procedure:

### Open a New Database

- In your xterm window type **p3** to start MSC/PATRAN. After that, create a new database named **mpc.db**.

New Database Name:



In the *New Model Preference* form set the following:

Tolerance:

 **Based on Model**

Approx. Max. Model Dimension:

Analysis Code:

Analysis Type:



- You will create a series of straight lines. Later, you will use these to form the outer loop (outside boundary) for the trimmed surface you will create in the last part of this exercise.

### Create the Model

To start creating your model, first click on **Geometry** in the *Main Window*, and then perform the following:

◆ **Geometry**

Action:

*Object:*

Curve

*Method:*

XYZ

*Vector Coordinates List*

&lt;2, 0, 0&gt;

*Origin Coordinates List*

[0, 0, 0]

**Apply**

A line should appear in your viewport as follows:

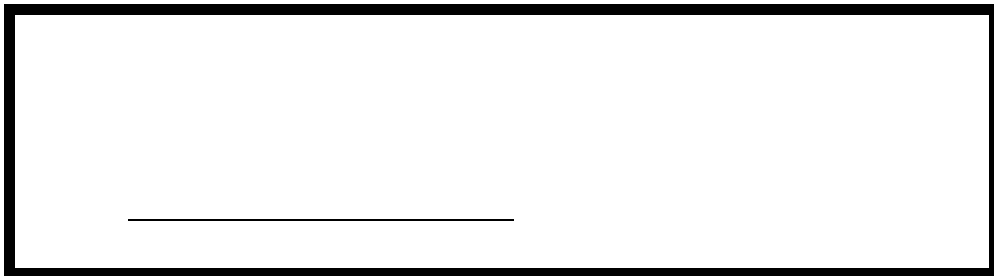
Secondly, change the *Origin Coordinates List* as follows:*Origin Coordinates List*

[2, 0.2, 0]

**Apply**

Your viewport should have two lines as shown below:

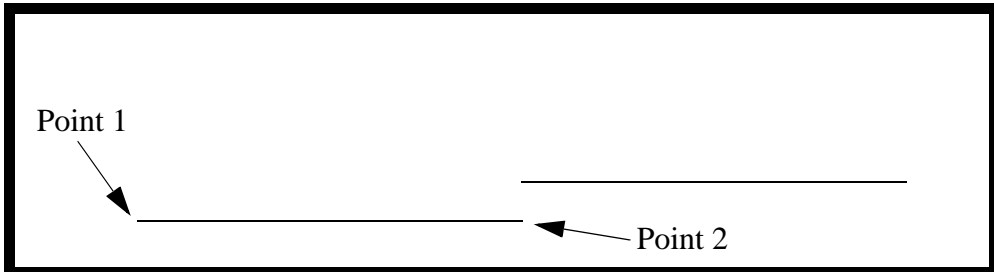
Next, enter the following on the *Geometry* form: **Auto Execute***Vector Coordinates List*

&lt;0, 0.4, 0&gt;

*Origin Coordinates List*

Point 1 2

**Apply**

Two more lines will show up in the viewport as shown below:

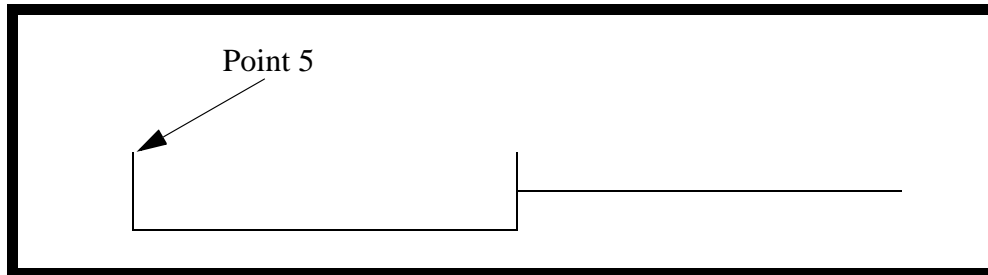

Next, create *line 5* by entering the following:

*Vector Coordinates List*

**<0.75, 0, 0>**

*Origin Coordinates List*

**Point 5**

**Apply**

Your viewport should look like the one shown below.

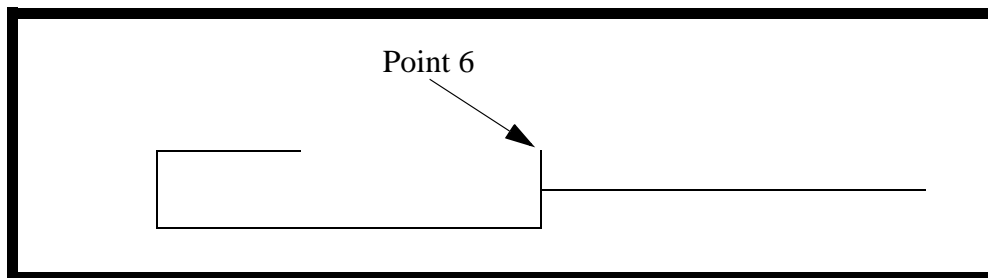

Next, enter the following to create *line 6*:

*Vector Coordinates List*

**<-0.75, 0, 0>**

*Origin Coordinates List*

**Point 6**

**Apply**

Your model should now look like the one shown below.

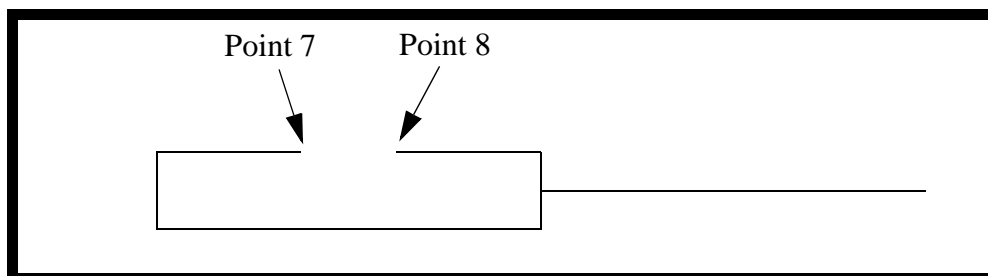

To create *lines 7 and 8*:

*Vector Coordinates List*

<0, 0.4, 0>

*Origin Coordinates List*

Point 7 8

**Apply**

Your viewport should look like the one shown below.

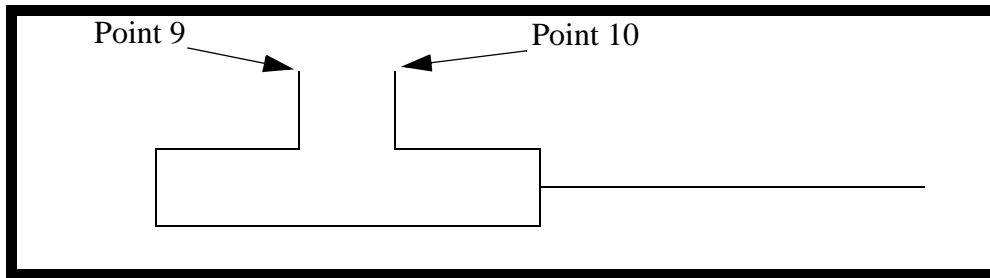

Lastly, create *line 9* by entering:

◆ **Geometry**

*Action:*

Create

*Object:*

Curve

*Method:*

Point

*Starting Point List:*

Point 9

*Ending Point List:*

Point 10

**Apply**

Your viewport should appear as the one shown below.

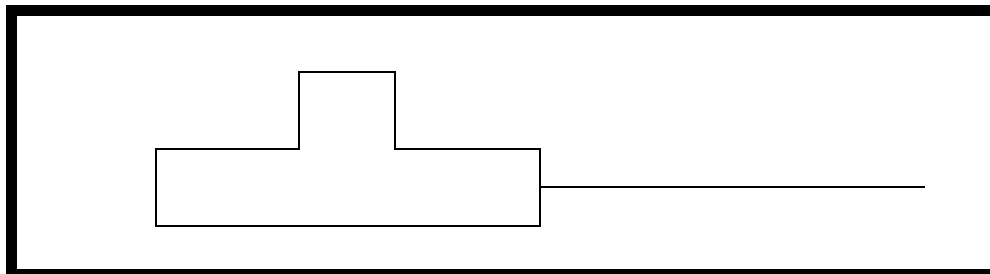

**Creating a Fillet**

3. Place fillets of 0.3 fillet radius at the appropriate locations.

**◆ Geometry**

Action:	Create
Object:	Curve
Method:	Fillet
Fillet Radius	0.3

Now click the *Curve/Point List* databox and screen select the curve that you wish to use as an edge, then the end point that is exterior to the fillet. Do this for both lines.

**■ Trim Original Curves**

**■ Auto Execute**

<i>Curve/Point 1 List</i>	Construct Point CurveUO.. ..(Point 6)...(Curve 6))
<i>Curve/Point 2 List</i>	Construct Point CurveUO.. ..(Point 10)...(Curve 8))

In order to get the above inputs in the *Curve/Point* databoxes, you should follow the pick order as shown below.

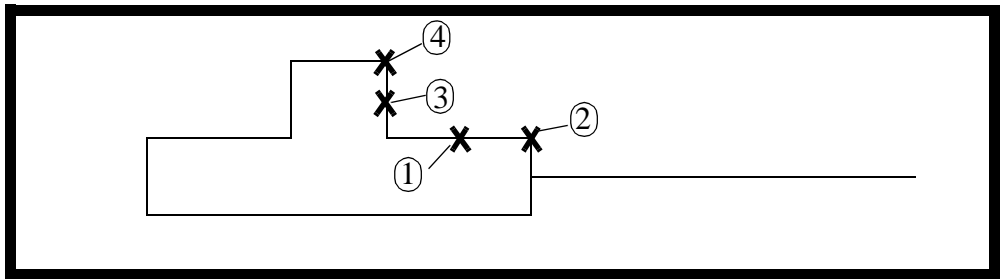

Repeat this step for the other side of the model. Your viewport should appear as the one shown below.

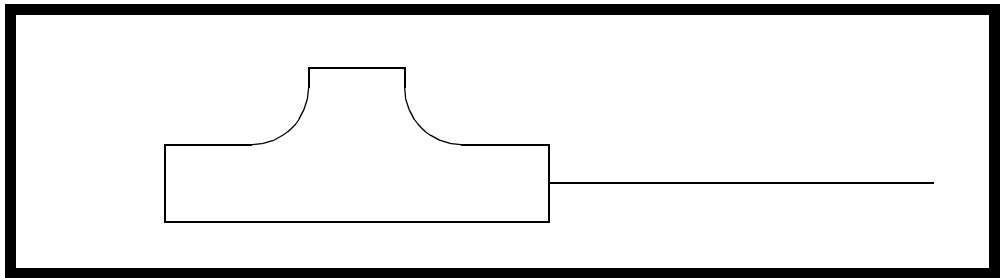

4. Chain together the lines in your model to create one continuous curve.

◆ **Geometry**

Action:

Object:

Method:

Option

**Chain  
together the  
lines**

Now click the **Auto Chain** button and another menu will appear on the screen. Enter the following:

Select a Start Curve

■ **Delete Constituent Curves**

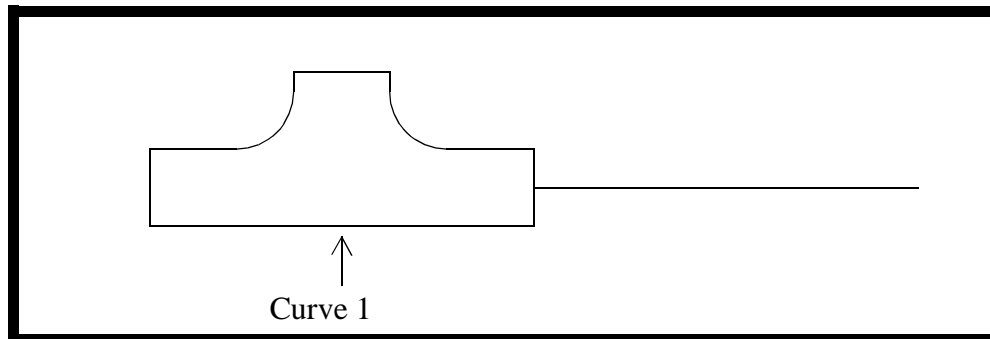

When prompted to confirm deletion of the original curves, press **Yes**. Repaint/Refresh the screen.

Press **Cancel** to close the Auto Chain form.

**Creating a Trimmed Surface**

5. Use this chained curve to define the outer loops of a planar-trimmed surface.

*Outer Loop List*

**Curve 12**

**Apply**

Answer **yes** when asked if you wish to delete the original curves.

**Displaying Surface Normal**

6. Display the normal direction of the surface.

First, use the **Iso 1 View** icon to change the model to an isometric display.

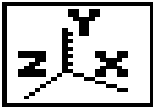

Now, enter the following to show the surface normal:

**◆ Geometry**

*Action:*

**Show**

*Object:*

**Surface**

*Method:*

**Attributes**

**Auto Execute**

*Surface List*

**Surface 1**

**Draw Normal Vectors**

**Apply**

The model should appear as shown below.

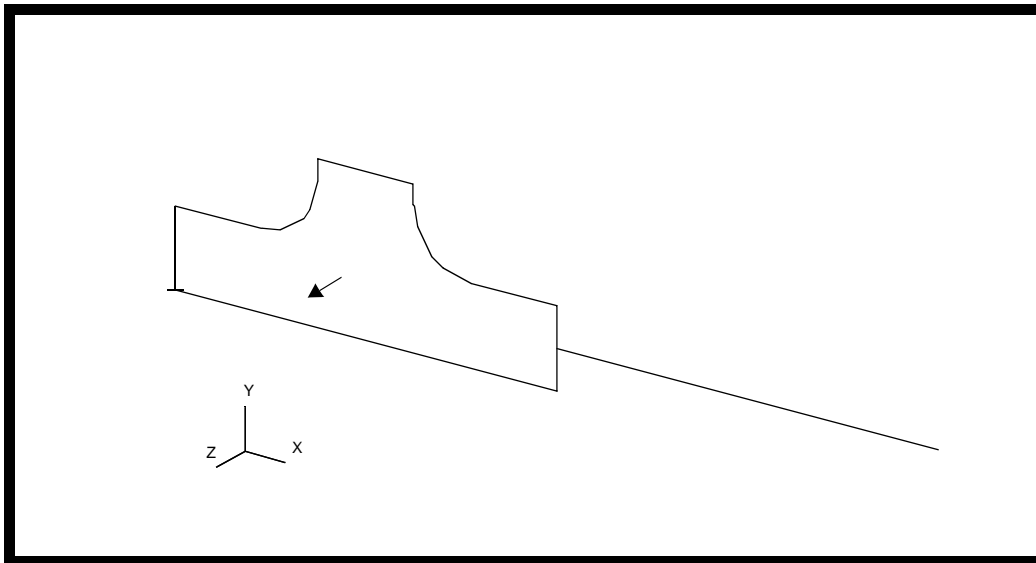

Notice the *Show Surface Attribute Information Table* appears with a variety of relative information such as edge information, area and surface type.

Press **Cancel** to close the table.

7. Create a cylindrical coordinate frame at -6 units in the y direction, having the local z-direction aligned with the global x-direction.

**Creating a Coordinate Frame**

◆ **Geometry**

Action:	<input type="text" value="Create"/>
Object:	<input type="text" value="Coord"/>
Method:	<input type="text" value="3Point"/>
Type:	<input type="text" value="Cylindrical"/>
Origin	<input type="text" value="[0 -6 0]"/>
Point on Axis 3	<input type="text" value="[1 -6 0]"/>
Point on Plane 1-3	<input type="text" value="[1 0 0]"/>
<input type="text" value="Apply"/>	

Next, change the view by select the following icon:

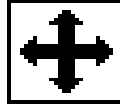
**Fit Viw Icon**

Your model should appear as shown below.

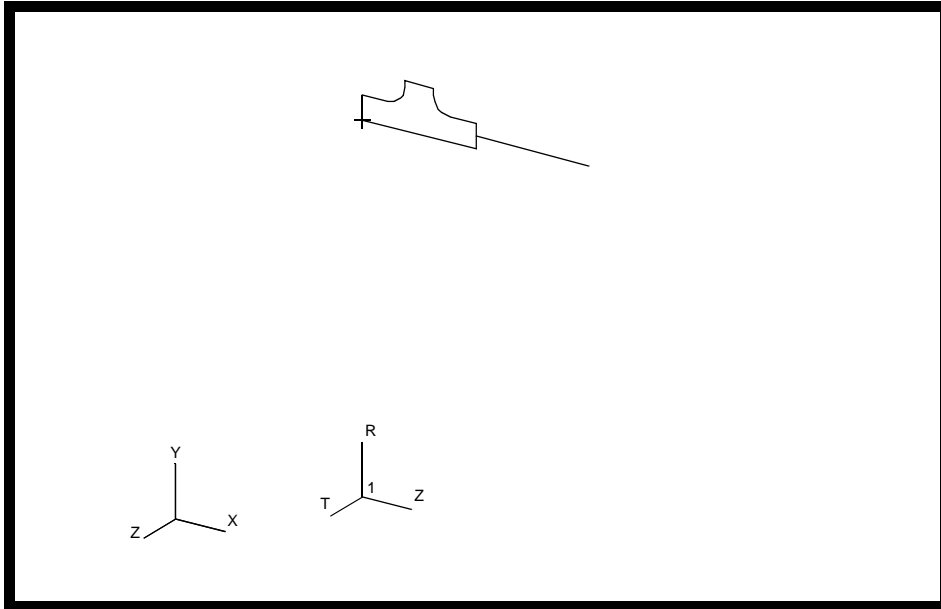

Lastly, close the database.

**File/Quit...**

You will need to keep the database for later exercises.