

LESSON 9

Generating a Hex Mesh Using Vector Sweep

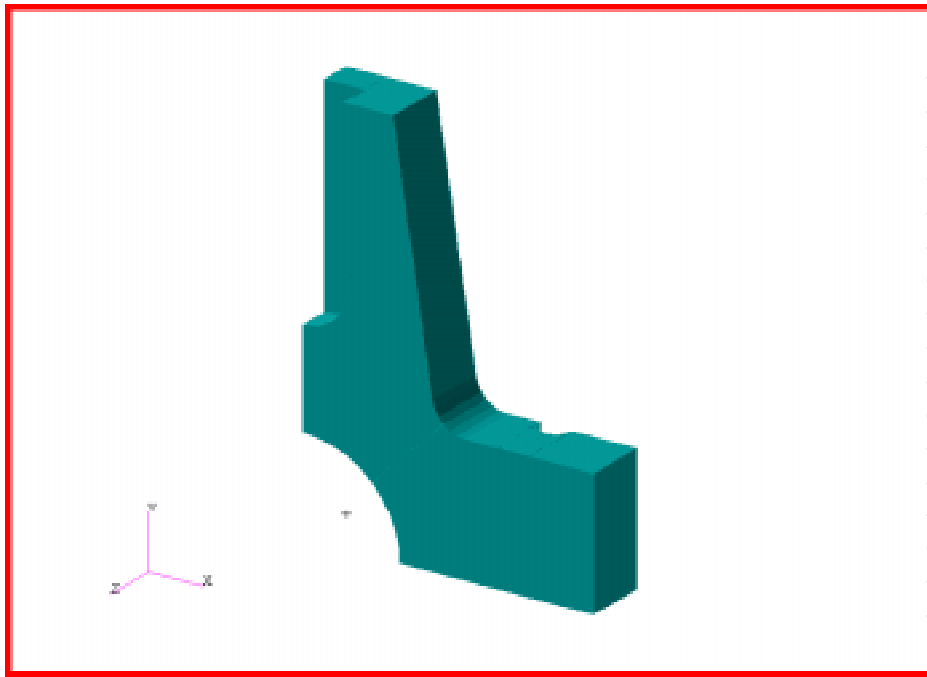

Objectives:

- Import a geometric model from an IGES file and create surfaces in the quarter model.
- Create meshes for the surfaces and create a vector field.
- Using sweep option, create solid finite elements by extruding and using the vector field.



Model Description:

In this exercise you will read in a model from an IGES file into a new MSC/PATRAN database. Then you will create surfaces for the lower right quarter of the model.

This exercise will show you an alternative to creating solid finite elements from solid geometry. Instead of creating solids and then meshing them, you can mesh surfaces and then sweeping the surface elements to make solid finite elements.

To create the solid finite elements, you will use the Sweep option that is available under the Finite Elements menu. Using the quad elements created on the surface, you will create the solid model by using extrusion and a vector field.

The view of the quarter model is as shown here.

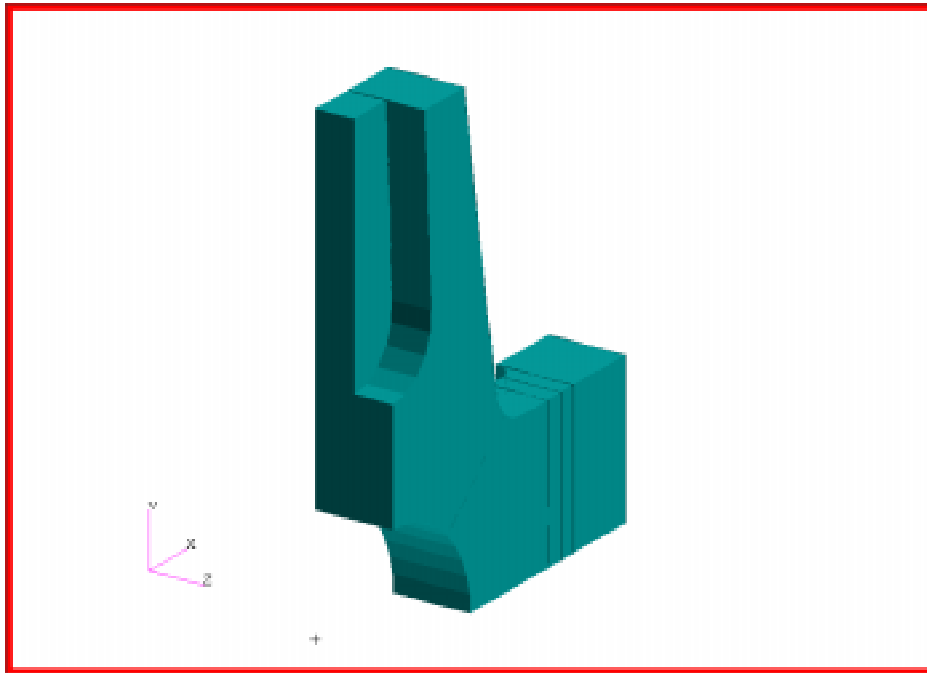

Suggested Exercise Steps:

- Start up MSC/PATRAN and open a new database called `con_rod.db`.
- Display QuickPick menu for quick display manipulations throughout

the exercise.

- Import IGES file called **con_rod_new.igs**.
- Create a curve to break a couple of existing curves to create the quarter model.
- Break a curve using an intersection point and delete the outer half.
- Change the geometric shrink to 0.20 to help grouping easier.
- Make a group called **quarter_model** that contains the lower right quarter of the model.
- Set the geometric shrink back to 0.0.
- Edit a corner curve before creating trimmed surfaces so that the meshes will be simpler.
- Complete the quarter model by creating additional curves.
- Create trimmed surfaces using the autochain feature.
- Create mesh seeds along the curved edges or entities.
- Create Quad4 meshes for the surfaces.
- Create lists the associate finite elements to the trimmed surfaces.
- Sweep the meshes into solid meshes using directional vectors and the lists.
- Create a vector spatial field.
- Complete the solid meshes by sweeping the remaining Quad4 elements using the vector field.
- Equivalence the elements to eliminate duplicate nodes.
- Verify the finite elements' boundaries.
- Close the database and quit MSC/PATRAN to end the exercise.

Files:

All the files used in this exercise are listed below. Each listing includes the file, where it originated, its format (text/binary) and summary information as to how it relates to this exercise.

File	Supplied/Created	Format	Description
con_rod_new.igs	Supplied	text	This is the IGES file that contains the basic connecting rod geometry. The data in this file will be used to create the all hex quarter model.
con_rod.db	Created	binary	This is a MSC/PATRAN database which is created in this exercise and is used to import the IGES file and create the hex model.

Exercise Procedures:

1. Start up MSC/PATRAN by typing p3 at the shell prompt. Open up a new database and call it con_rod.db.

New Database Name:

In the New Model Preference form set the following:

Tolerance:

 Based on Model

Approximate Maximum Model Dimension:

Analysis Code:

Analysis Type:

2. Import the IGES file con_rod_new.igs.

Open a New Database

Import an IGES file

<i>Object:</i>	<input type="text" value="Model"/>
<i>Source:</i>	<input type="text" value="IGES"/>
<i>Import File:</i>	<input type="text" value="con_rod_new.igs"/>
<input type="button" value="Apply"/>	

An window containing the summary of the IGES file will appear. Click **OK** to import the entities from the file.

3. If the display seems to be empty at this time. From your Toolbar, select the icons below to get a good idea of the model.

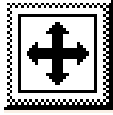

Fit View

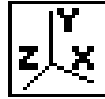

Iso View 1

The display should be similar to the one below:

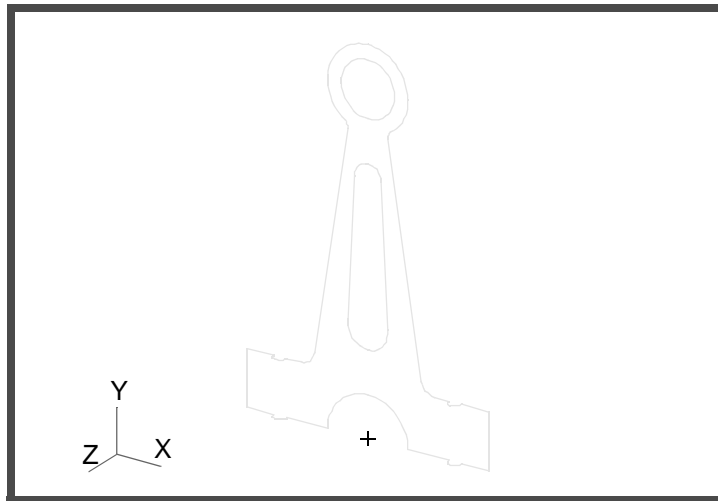

4. To create the lower right quarter of the model, we will edit the model. Create a curve to intersect the two curves.

◆ Geometry

<i>Action:</i>	<input type="button" value="Create"/>
<i>Object:</i>	<input type="text" value="Curve"/>
<i>Method:</i>	<input type="text" value="XYZ"/>
<i>Vector Coordinates List</i>	<input type="text" value="<60 0 0>"/>
<input type="checkbox"/> Auto Execute	

Turn off Labels and Change Views

Create a Curve

Origin Coordinates List

[0 125 0]

Apply

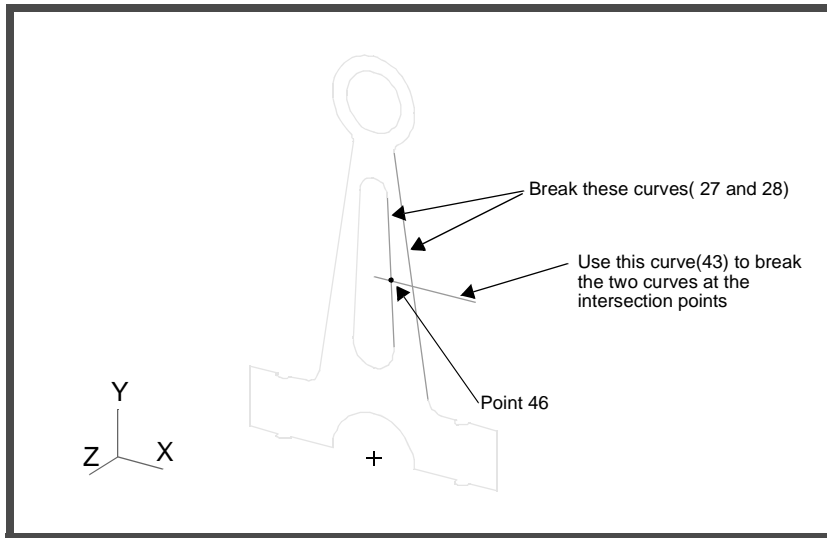

- Break curves 27 and 28 using the intersection points with the previously created curve 43.

◆ **Geometry**

Action:

Edit

Object:

Curve

Method:

Break

Option:

Point

■ **Delete Original Surfaces**

■ **Auto Execute**

Curve List

Curve 27

Break Point List

see below

**Break Curves
at the
Intersection
Point**

Click in the databox and a Select Menu appears beside the Geometry menu. Pick the intersection icon and the menu changes.

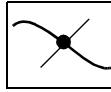

Pick the curve icon and then select the first and second intersecting curves in the viewport.



Click **Yes** when asked if you want to delete the original curves.

Repeat the procedures with curve 28.

6. Now break curve 43 using the inside point created at the intersections. Click **Yes** when asked if you want to delete the original curves.

■ **Delete Original Curves**

■ **Auto Execute**

Curve List

Curve 43

Break Point List

Point 46

Of the two curves created, delete the one on the right.

Action:

Delete

Object:

Curve

Curve List

Curve 49

Apply

7. Change the geometric shrink using *Display/Geometry...* option to make picking the entities easier.

Display/ Geometry ...

Geometric Shrink

0.20

Apply

Cancel

Break a Curve using a Point

Change the Geometric Shrink

The following is what the display should look like.

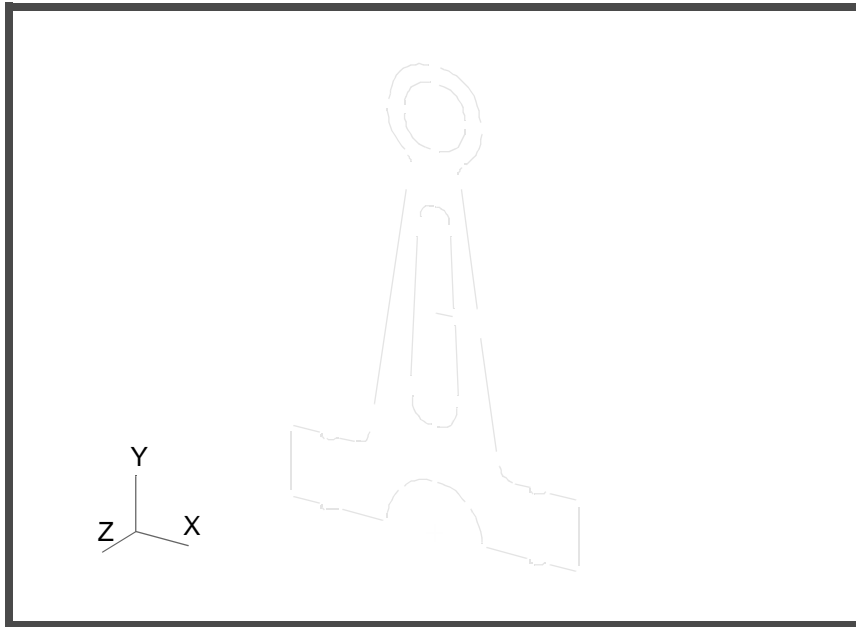

From the Toolbar menu, select the default view icon.



Front View

8. Create a group called **quarter_model** containing the lower right quarter of the model.

Create a Group

Group/Create...

New Group Name

quarter_model

■ **Make Current**

■ **Unpost All Other Groups**

Entity Selection

select entities shown in figure below

Click in the databox and using the cursor in the viewport, pick the entities that made up the lower right quarter of the model (see the figure below).

Apply

Cancel

* Using **Display/Geometry** ...option, change the geometric shrink back to 0.0.

The view of the model should be like the one shown..

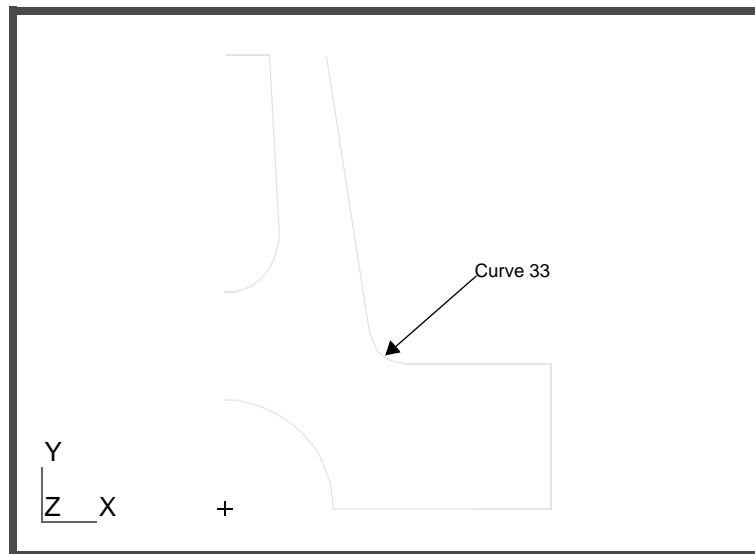

9. Break curve 33 using the parametric option.

◆ **Geometry**

Action:

Edit

Object:

Curve

Method:

Break

Option:

Parametric

Break Point

0.5

■ **Delete Original Surfaces**

■ **Auto Execute**

Curve List

Curve 33

Click **Yes** when asked if you want to delete the original curves.

10. Turn on the point and curve labels.

Display/Entity Color/Label/Render...

Point:

■ **Label**

Break a Curve

Labels On

Curve: Label*Tsurf:* Label

Now, create 5 curves(51 through 55) to close the surfaces. Refer to the next graphic to locate the position of the curves to make.

Create Curves**◆ Geometry***Action:* *Object:* *Method:* *Option:* **■ Auto Execute***Starting Point List* *Ending Point List*

Click on the Starting Point databox and make sure the point icon in the Select Menu is highlighted. Use the cursor to pick the points on the screen. The curves will be created automatically since the Auto Execute button is on. Repeat the steps until all five curves are created.

The display should now be like this:

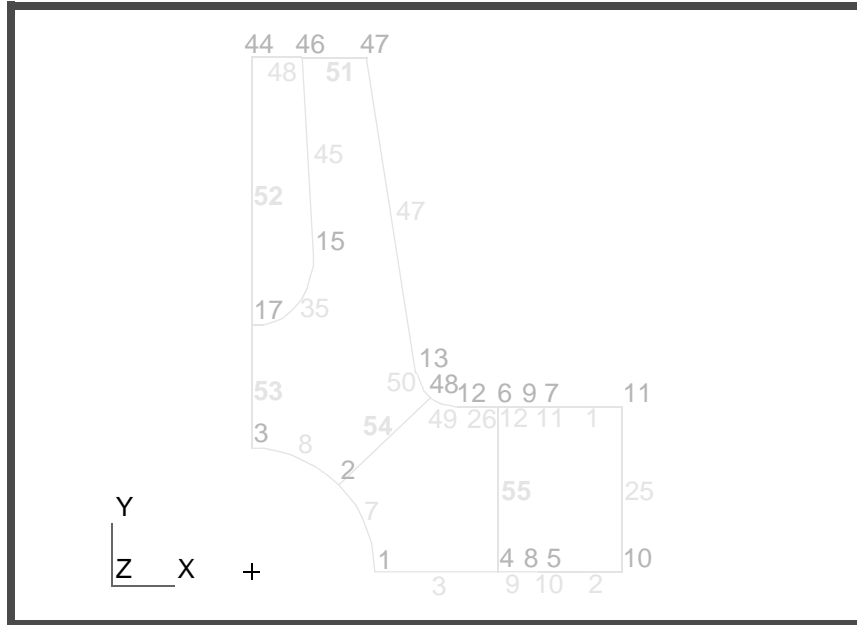

11. Turn off the Point labels. Create trimmed surfaces.

Create Trimmed Surfaces

◆ **Geometry**

Action:

Create

Object:

Surface

Method:

Trimmed

Option:

Surface

Auto Chain...

Current Group Only

Highlight Chain Creation

Delete Constituent Curves

You do not want to delete the constituent curves because you need the curves to complete other trimmed surfaces.

Auto Execute

You will be using the autochain feature to create a closed loop bonded by curves 26, 49, 54, 7, 3, and 55 (Your ID numbers may differ due to the order in which you created the curves. Refer to the figure below).

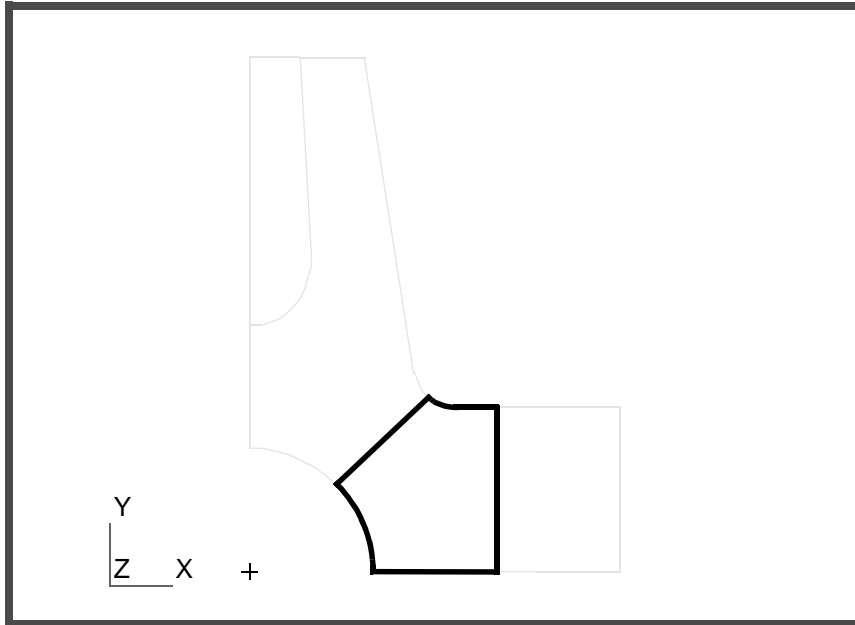

Click in the databox and using the cursor, pick curve 26 to start the chain in the viewport.

Select a Start Curve

Curve 26

The curve selected to be the next in the chain is highlighted in magenta color and has a filled circle on its midlength. The identity of the curve is also shown in the Choose Curve to Continue databox.

Click **Next** if the curve selected is not the one you want and/or click **OK** to accept the selection. Please refer to the next graphic to determine which surfaces need to be created.

When a chain is completed, the chained curve is shown in magenta color.

Cancel

Now continue with the geometry form.

■ **Delete Outer Loop**

Outer Loop List

Curve 56

Curve 56 is the chained curve just created..

Apply

Click **Yes** when asked if you want to delete the original curves. A trimmed surface is created. Repeat the steps to create the rest of the surfaces. The resulting surfaces are shown below.

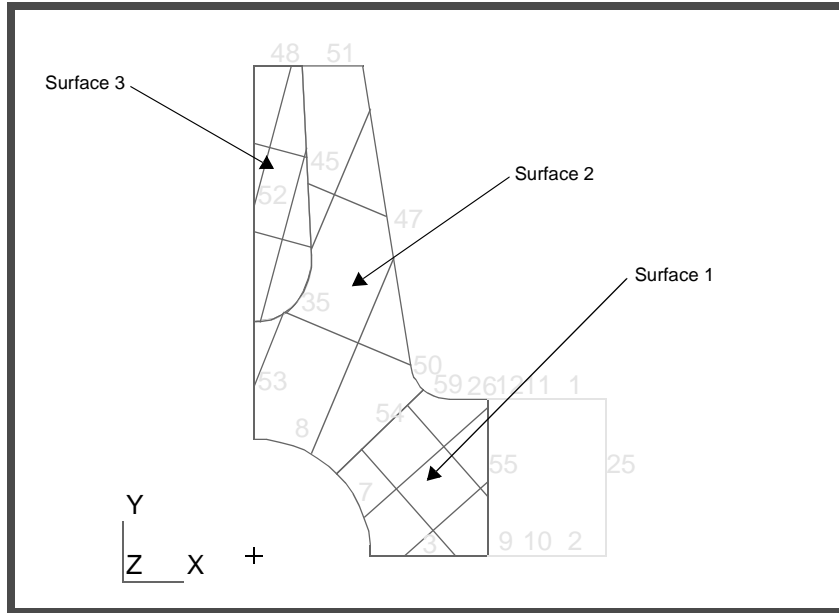

- Prepare the geometry for meshing. Create mesh seeds along the curved entities. See the next graphics to determine where the mesh seeds are to be.

Create Mesh Seeds - Uniform

◆ **Finite Elements**

Action:

Create

Object:

Mesh Seed

Type:

Uniform

◆ **Number of Elements**

Number:

3

Curve List:

See Figure

Apply

Repeat the seeding with an element number of 5 on curves 7, 8, and 35.

Shown here are the curves and number of elements needed.

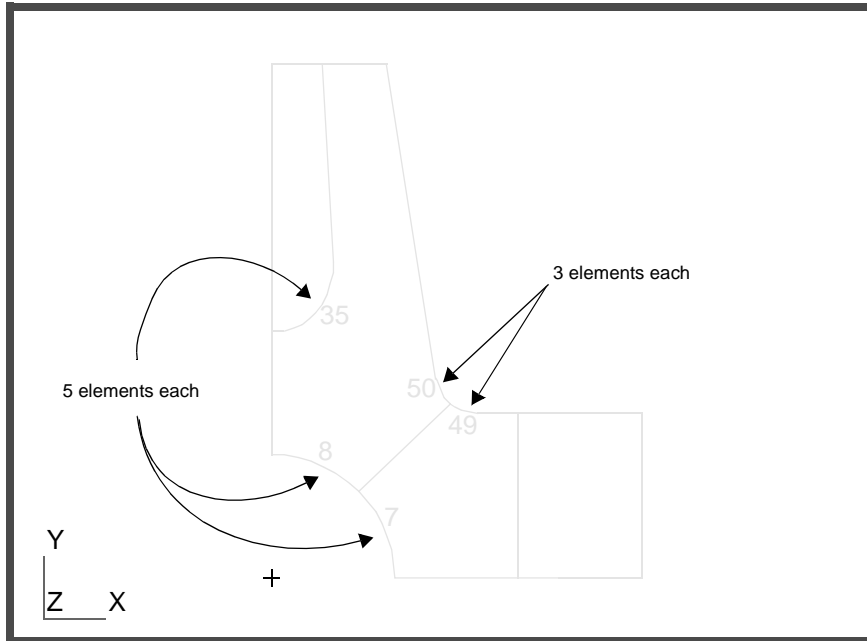

Change the view using **Viewing/Angles...** to see the other curved entities.

Change View Angles

Viewing/ Angles...

Method

◆ **Model Absolute**

Angles

55.0 5.0 0.0

Apply

Cancel

Use the Select Corners icon in the Toolbar to zoom into the area shown in the graphic below.



Select Corners

Change the type in the Finite Elements form to One Way Bias and you will see arrows displayed on the model.

Type:

One Way Bias

Here is what the display looks like.

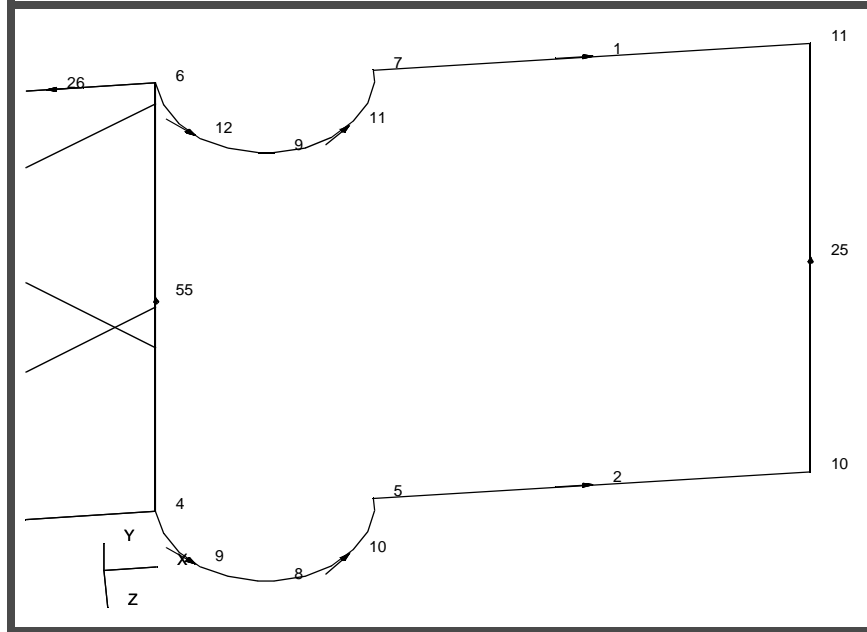

Since the arrows for curve 9-12 are pointing in the same direction, remember to change the ratio of L2/L1 for the different curve.

Create Mesh Seeds - One Way Bias

◆ **Num Elems and L2/L1**

Number:

L2/L1

■ **Auto Execute**

Curve List:

L2/L1

■ **Auto Execute**

Curve List:

Select Fit View icon from the QuickPick menu.



Fit View

The resulting mesh seeds are as follows:

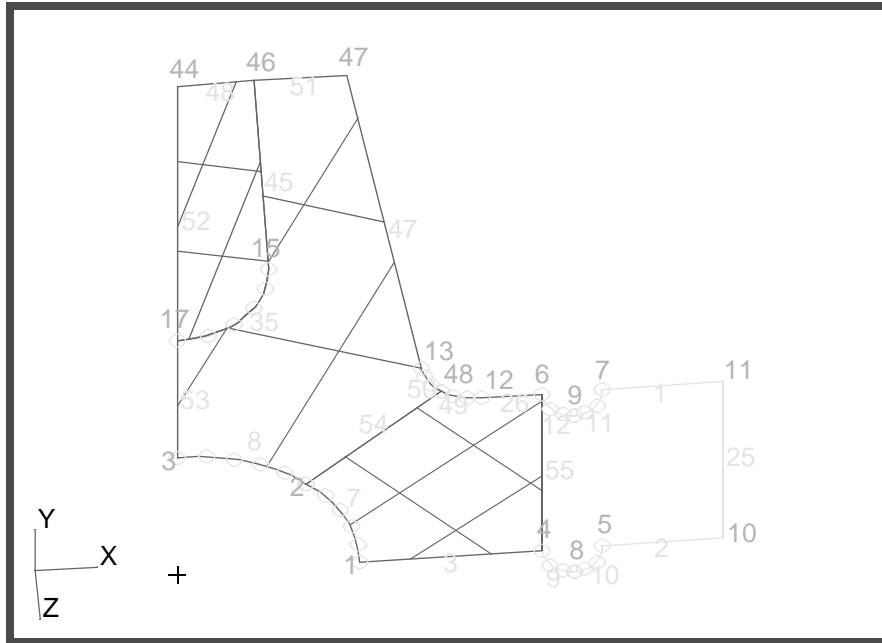

13. Set the view to default view and turn off all labels. Create meshes for the surfaces.

**Create Mesh
for Surfaces**

◆ **Finite Elements**

Action:

Create

Object:

Mesh

Type:

Surface

Global Edge Length

5

◆ **Paver**

Surface List

Surface 1:3

Apply

Also mesh the rest of the surfaces using the 2 Curves option.

Type:

2 Curves

Global Edge Length

5

Auto Execute

*Curve 1 List***Curve 1 11 12***Curve 2 List***Curve 2 10 9****Apply**

The resulting meshes are as shown below.

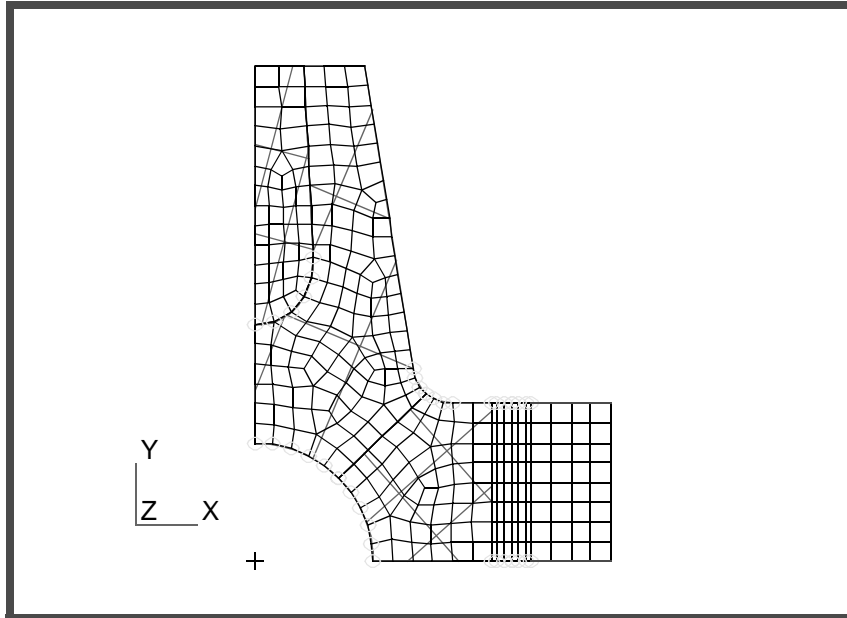

14. Create two lists. One containing the elements associated with the connector rod inner web, Surface 3, and the other containing elements associated with the other surfaces, Surface 1 and 2.

Tools/ List/Create...*Model:***FEM***Object:***Element***Method:***Association**

Pick Surface from the Association List by highlighting it.

*Surface***Surface 3***Target List*◆ **A****Apply**

The List A now shows Element 162:196 in the 'lista' contents databox (*numbers will vary, depending on how many elements are created by the paver during meshing*).

Surface

Target List

The List B shows Element 1:161 in the 'listb' contents databox.

15. Create solid meshes by sweeping the surface meshes.

◆ Finite Elements

Action:

Object:

Type:

**Create Solid
Meshes by
Sweeping
Elements**

Set the number of elements in the Mesh Control form equal to 2.

Number=

Direction Vector

■ Delete Original Elements

Base Entity List

Change the number of elements in the Mesh Control form to 4.

Number=

Direction Vector

Base Entity List

The resulting solid meshes are as follows:

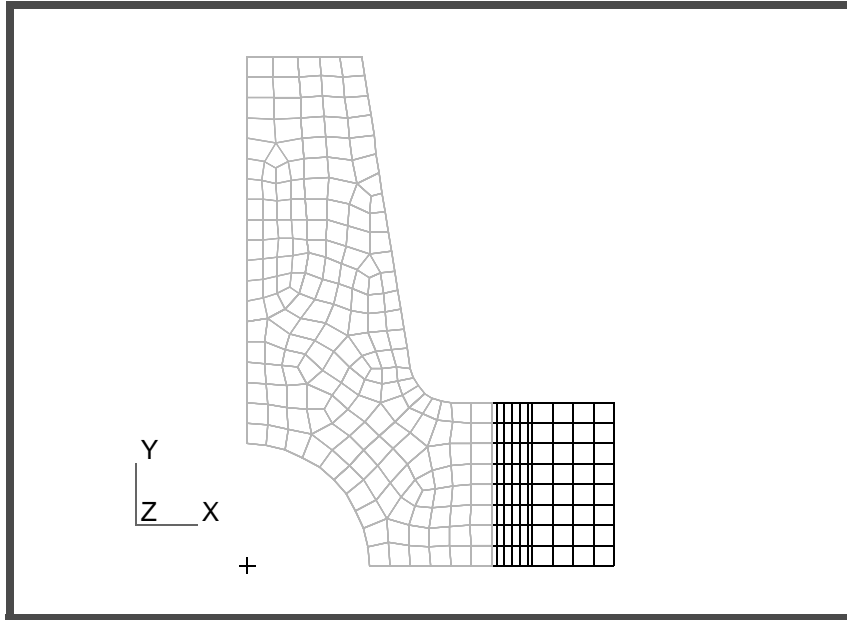

To get a better view, click on the Hidden Line and Isometric View icons in the Toolbar.

Change
Display



Hidden Line

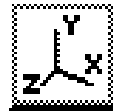

Isometric View



16. Create a vector spatial field.

**Create a
Spatial Field**

◆ **Fields**

Action:

Create

Object:

Spatial

Method:

PCL Function

Field Name

direction_vector

Field Type

◆ Vector

First Component

0.

Second Component

0.

Third Component

20.0 - 'z

Apply

Set the display back to Wireframe and Default View before continuing to the next step.

17. Create the rest of the solid elements by sweeping the surface elements along the vector field.

**Create Solid
Meshes**

◆ **Finite Elements**

Action:

Sweep

Object:

Element

Type:

Vector Field

Make sure that the Mesh Control form is still showing 4 as the number of elements. Click **OK**.

Field Name

direction_vector

■ **Delete Original Elements**

Base Entity List

Elm 197:276

Click in the databox and use the cursor to select the rest of the existing surface elements.

Apply

Equivalence the Meshes

Equivalence the finite elements to eliminate duplicate nodes.

Action:

Equivalence

Object:

All

Method:

Tolerance Cube

Apply

Now you can verify the finite elements' boundaries.

Action:

Verify

Object:

Element

Method:

Boundaries

Display Type

◆ **Free Edges**

Apply

Set the display to Isometric View and the resulting display of the model is as follows:

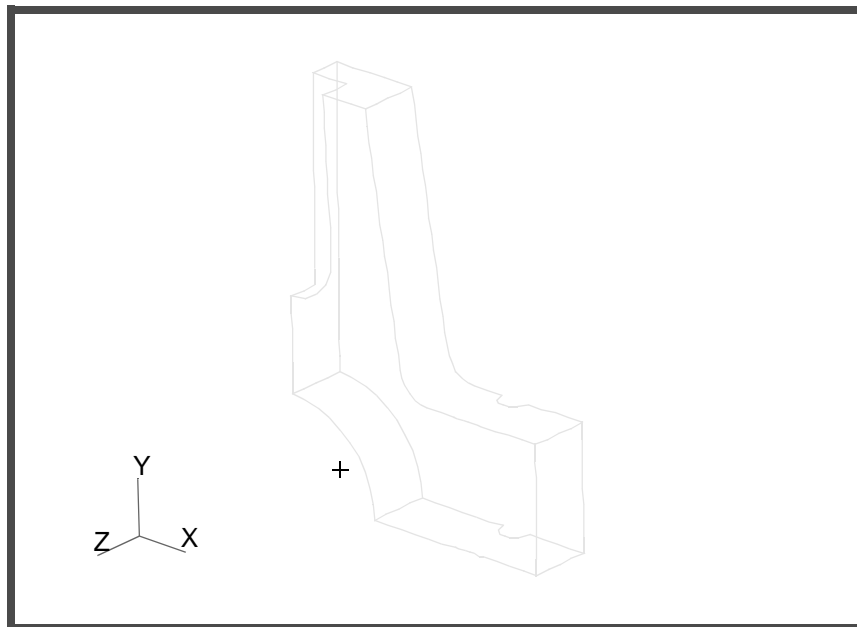

Hit the Hidden Line icon in the Toolbar and the display changes to hidden line representation of the element boundaries.

Hit Reset Graphics to go back to the wireframe model and close the database. Quit MSC/PATRAN to end this exercise.