

LESSON 15

Mass Properties Calculations

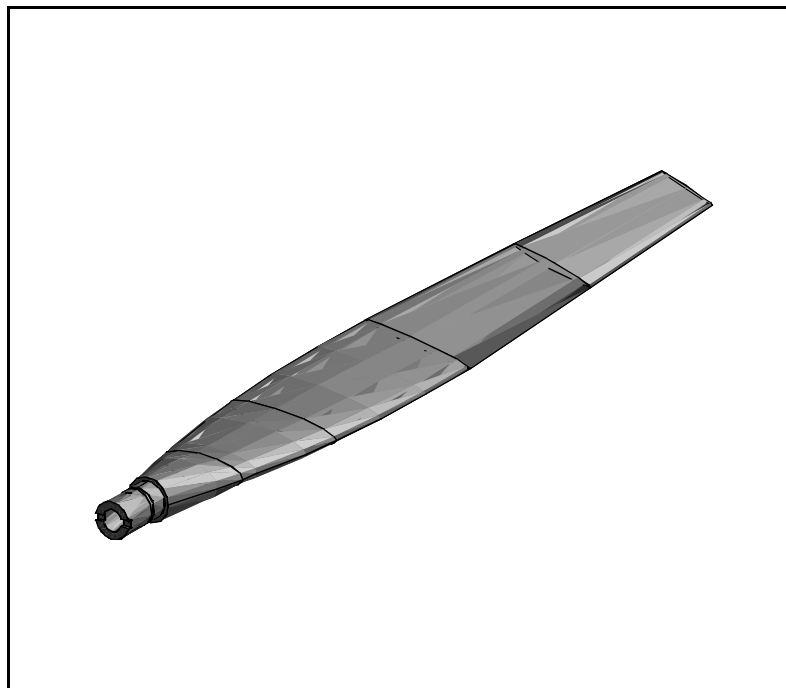

Objectives

- Import a unigraphics express file and apply mass properties to the propeller.



Suggested Exercise Steps

- Open a new database and name it fin.db.
- Import the Express Neutral file prop_11.1.exp
- Create the material properties for steel and apply it to the model
- Review the Mass Properties
- Create a projection of the model, then create a surface from that projection. Define a field to represent the thickness of the model
- Again review the Mass Properties and compare it to the previous results
- Mesh the base of the solid

Exercise Procedure

1. Create a new database named **fin.db**.

File/New ...

New Database Name:

fin

OK

The *New Model Preferences* form appears.

Tolerance:

◆ **Based on Model**

Analysis Code:

MSC/NASTRAN

Analysis Type:

Structural

OK

2. Import an Express Neutral file.

File/Import...

Object:

Model

Source:

Express Neutral

Import File:

prop_11.1.exp

Open a New Database

Import a Express Neutral File

Apply

A message form appears.

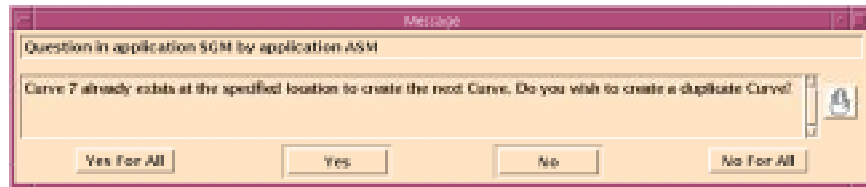

No For All

Close the *Import Summary* form.

OK

The *Import Tolerances* form appears. A tolerance mismatch may have caused the model to import improperly. The model should therefore be re-imported with a new model tolerance.

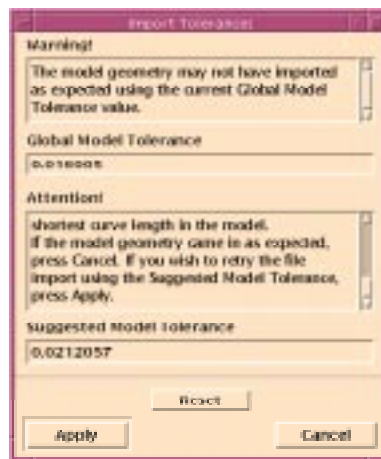

Apply

A message form appears. Again, do not duplicate geometry.

No for All

A new *Import Summary* form appears.

Start Time	End Time	Elapsed Time	CPU Time
16-Aug-96 11:43:14	16-Aug-96 11:44:20	00:01:06	00:00:06

Express Neutral File Imported

Model: /Users/chrise/Work/prop/prop.d1.t.exp

Geometry Types	Quantity Imported
Ordinary B-rep Solid	1
Line	6
Wire	1
B-Spline Curve	7

Geometry Types	Quantity Created
Curve	14
Solid	1

OK

OK

The imported model should appear as shown below.

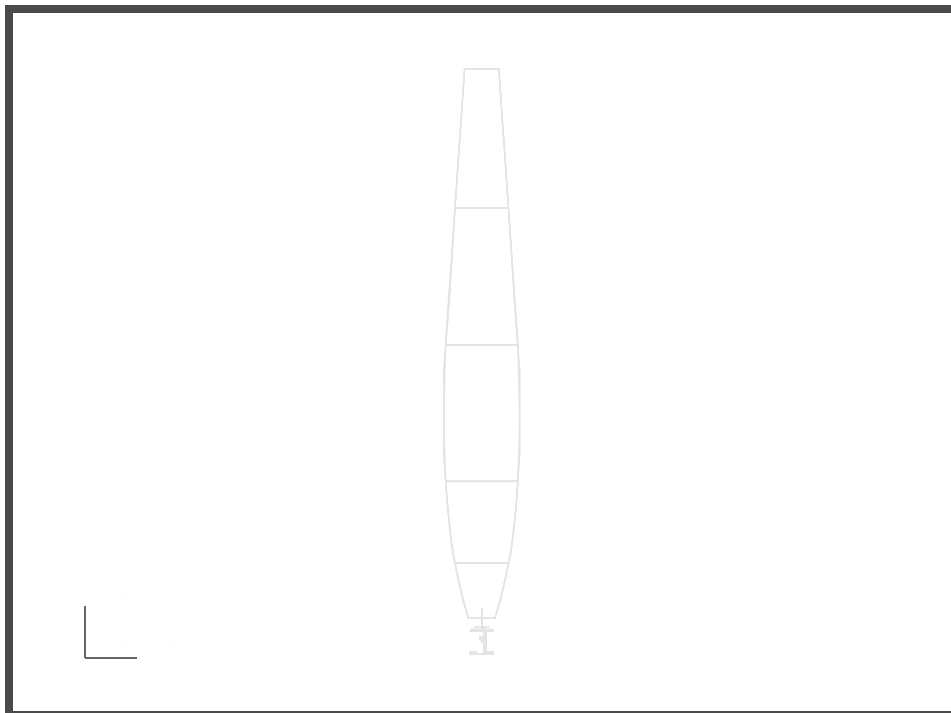

3. To keep the imported solid separate from geometry that will be created later in the exercise, create a group named **solid** and add all solids to it.

Group/Create...

Action:

Create

New Group Name:

solid

■ **Unpost All Other Groups**

In order to select **Solid 1**, use the following entity select icons:



Geometric Entity



Solid

Entity Selection:

Solid 1

Apply

Cancel

4. Create a material named **steel**.

◆ **Materials**

Action:

Create

Object:

Isotropic

Method:

Manual Input

Material Name:

steel

Input Properties...

The *Input Options* form appears.

Elastic Modulus:

30e6

Poisson Ratio:

0.3

Density:

0.0029

Apply

The phrase **Linear Elastic - [,,,] - [Active]** appears in the *Current Constitutive Models* box.

Cancel

Create a New Material

5. Create a property set to apply to the solid model. Name it **fin_3d_solid**.

**Create a
Property Set**

◆ **Properties**

<i>Action:</i>	<input type="text" value="Create"/>
<i>Dimension:</i>	<input type="text" value="3D"/>
<i>Type:</i>	<input type="text" value="Solid"/>
<i>Property Set Name:</i>	<input type="text" value="fin_3d_solid"/>
<input type="button" value="Input Properties..."/>	

The *Input Properties* form appears.

<i>Material Name:</i>	<input type="text" value="m:steel"/>
<input type="button" value="OK"/>	
<i>Select Members:</i>	<input type="text" value="Solid 1"/>
<input type="button" value="Add"/>	
<input type="button" value="Apply"/>	

Create a user-defined coordinate frame at the base of the fin.

◆ **Geometry**

<i>Action:</i>	<input type="text" value="Create"/>
<i>Object:</i>	<input type="text" value="Coord"/>
<i>Method:</i>	<input type="text" value="3Point"/>
<i>Origin:</i>	<input type="text" value="[0 -2 0]"/>
<i>Point on Axis 3:</i>	<input type="text" value="[0 -2 1]"/>
<i>Point on Plane 1-3:</i>	<input type="text" value="[1 -2 0]"/>
<input type="button" value="Apply"/>	

The new coordinate frame can be seen in the viewport.

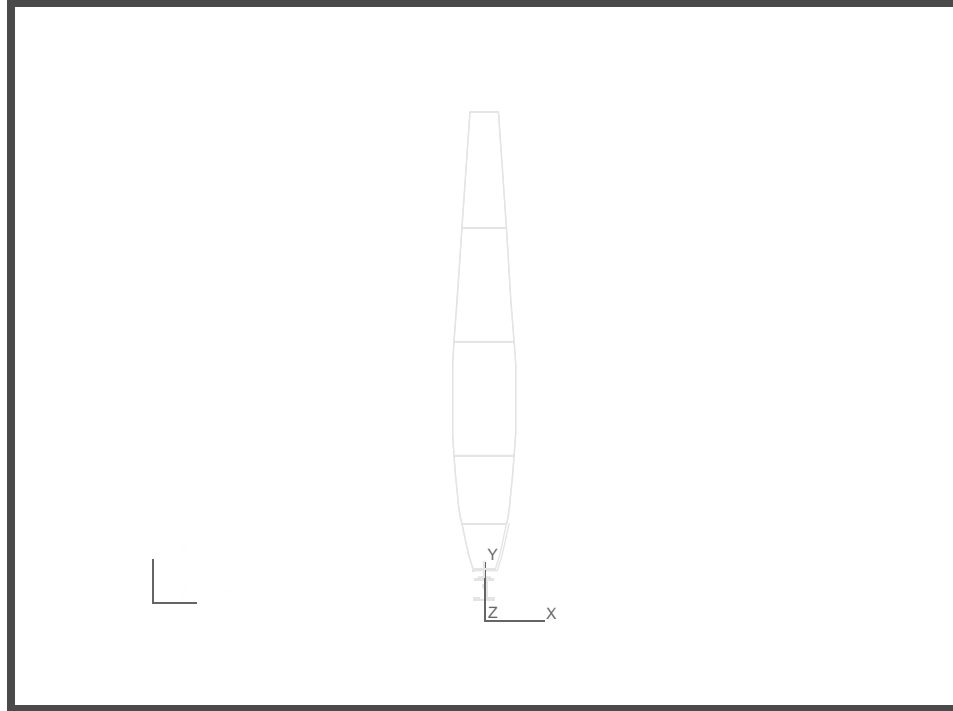

6. Determine the mass properties for the solid model of the fin.

Determine Mass Properties

Tools/Mass Properties...

Action:

Show

Dimension:

3D

Define Region...

The *Region for Mass Properties* form appears.

Region:

Group

Include:

Geometry

Select Groups:

solid

OK

Relative to Coordinate Frame:

select newly created **Coord 1**

■ Create Princ. Coord. Frame

Apply

The *Mass Properties Display* form appears.

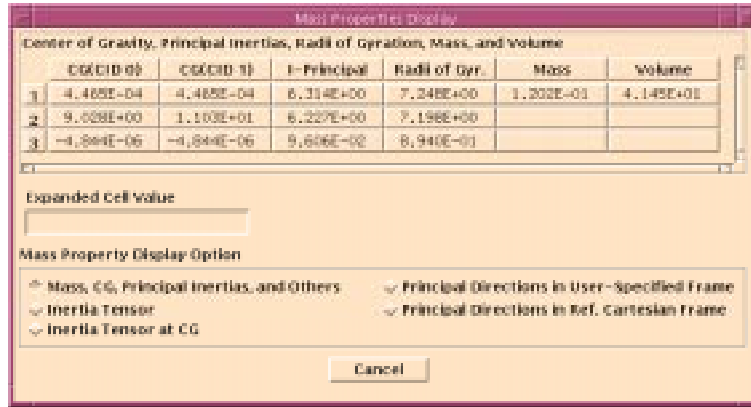

View the inertia tensor.

Mass Property Display Option: **◆ Inertia Tensor**

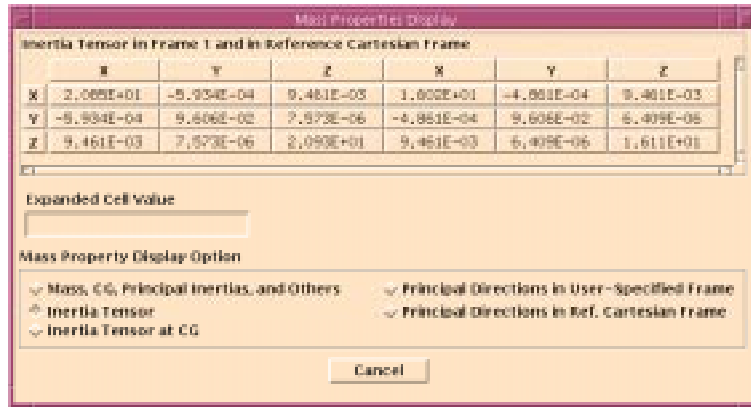

Cancel

Close the Mass Properties Form.

Cancel

7. Create a group named **fin_2d**. This group will contain a 2D projection of the solid model.

Group/Create...

Action:

Create

New Group Name:

fin_2d

Make Current

Unpost All Other Groups

Apply

Cancel

Create a Projection

8. Create a 2D projection of the solid fin geometry.

◆ **Geometry**

Action:

Create

Object

Curve

Method

Project

Project Onto:

Plane

Option:

Normal to Plane

Auto Execute

Select the curves that define the left and right sides of the blade. Click on the **Edge** icon to select the edge of the solid, and shift-click to select the edges in the following order:

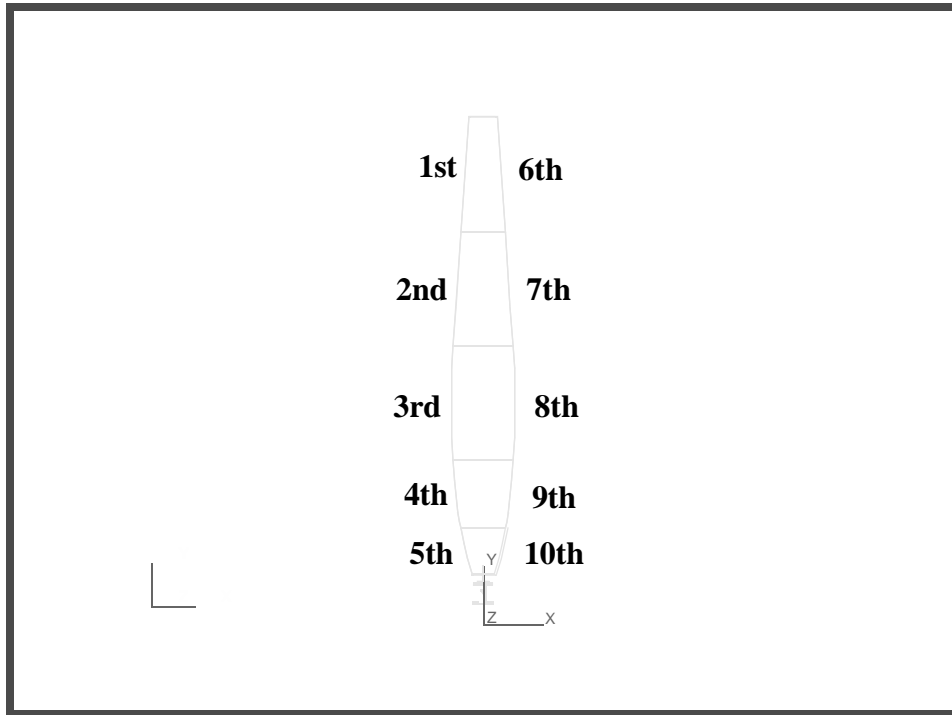
**Edge***Curve List:*

see figure above

*Plane List:***Coord 0.3**

To select **Coord 0.3** click on the **Axis 3** icon



Then hold down the middle mouse button to rotate the coordinate axis until you can screen select the **Z axis**.

Apply

9. Unpost all other groups to view the projection only

Group/Post...

*Action:***Post***Select Groups to Post:***fin_2d****Apply****Cancel**

The projected curves appear as follows.

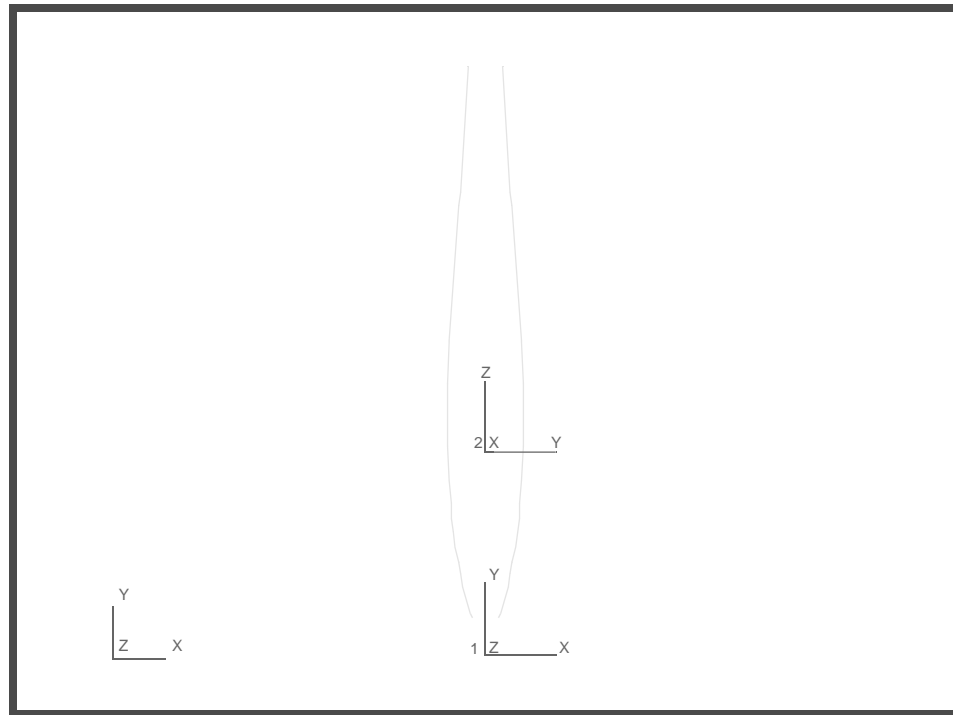

10. Create a surface using the two projected curves.

*Action:***Create***Object:***Surface***Method:***Curve***Option:***2 Curve**

To select the curves, be sure to use the following entity select icon:

**Curve***Starting Curve List:*

select all curves on left side

Ending Curve List:

select all curves on right side

The function autoexecutes.

The surface should appear as follows:.

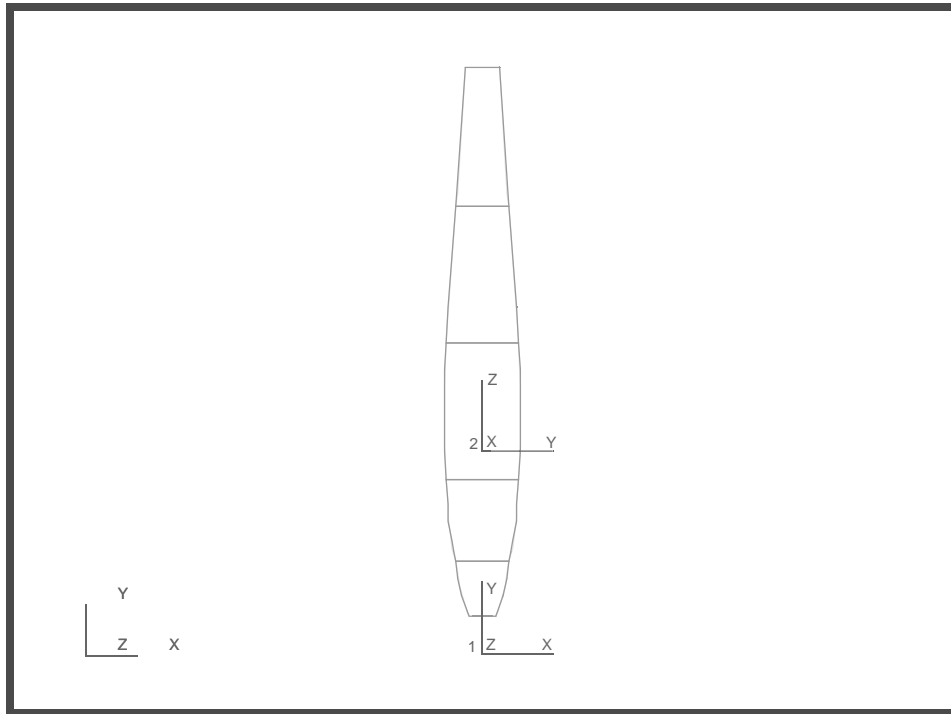

11. Create a field to represent the thickness of the surface.

◆ **Fields**

Action:

Create

Object:

Spatial

Method:

PCL Function

Field name:

fin_thickness

Field Type:

◆ Scalar

Coordinate System Type:

◆ Real

Coordinate System

Coord 0

Scalar Function ('X', 'Y', 'Z):

$0.3 * \text{abs}(\text{cosr}(0.5 * 'X))$

Apply

Create a Field

12. Create a property set for the 2D surface model.

◆ **Properties**

Action:

Create

Create a Property Set

Dimension:

Type:

Property Set Name:

The *Input Properties* form appears.

Material Name:

Thickness:

Select Members:

13. Check the mass properties for the surface.

Tools/Mass Properties...

Action:

Dimension:

The *Region for Mass Properties* form appears.

Select Groups:

**Determine
Mass
Properties**

The *Mass Properties Display* form appears. Compare the inertia tensor to the one calculated for the solid.

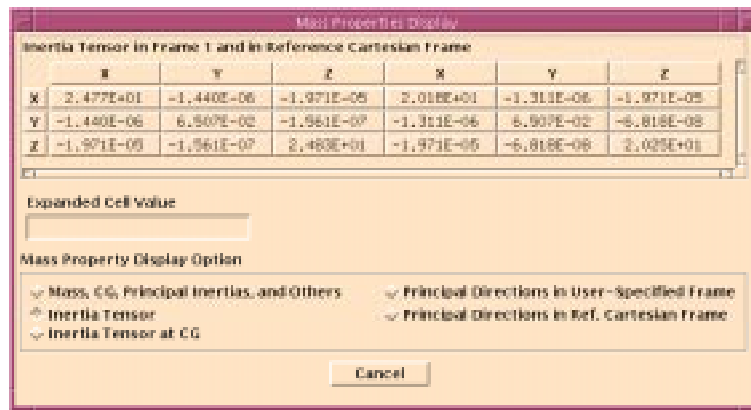

Cancel

Check the *Warnings* form. Note that the curves and points were excluded from the calculation.

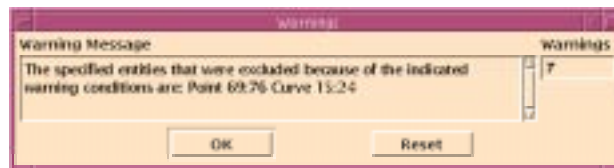

OK

- Calculate mass properties again using the 2D plane stress. The thickness of the blade is set to 1 by default.

Action:

Show

Dimension:

2D Plane Stress

Apply

The *Mass Properties Display* form appears. Compare the inertia tensor to the ones previously generated.

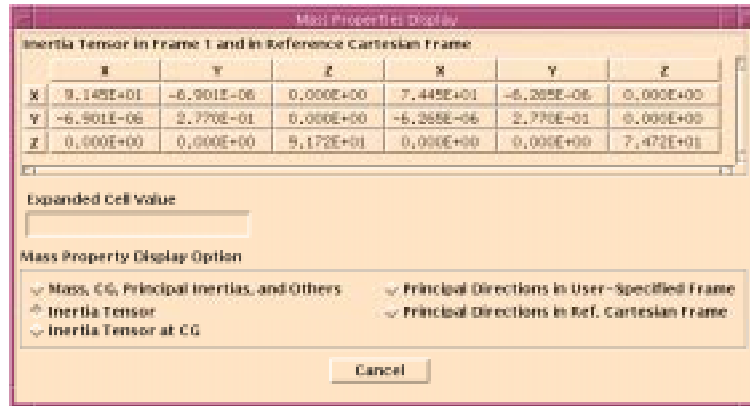

Cancel

Cancel

Close the warning form.

OK

Create a Surface Mesh

- Tet mesh the base of the solid model of the fin. The geometry of the blade is very simple to mesh, so it will not be discussed. Besides, the base of the fin is usually where the focus of the analysis is directed, as that is usually the region of highest stresses.

Post the **solid** group and unpost all other groups.

Group/Post...

Select Groups to Post:

solid

Apply

Cancel

Create a plane at the base of the blade to cut the solid.

◆ Geometry

Action:

Create

Object:

Plane

Method

Vector Normal

Plane Offset Distance:

0.35

Vector List:

Coord 0.2

Apply

Break the solid using the plane.

Action:

Edit

Object:

Solid

Method:

Break

Option:

Plane

 Auto Execute*Solid List:*

Solid 1

Break Plane List:

Plane 1

Apply

A message form appears. Do not delete the original solids.

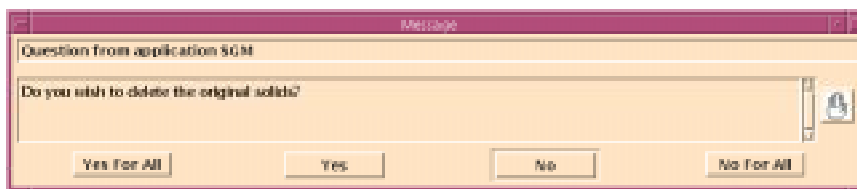

No For All

Clean up the display using the following toolbar icon:

**Refresh Graphics**Create a new group named **solid_with_tetmesh** and add the base of the newly trimmed solid to it. Unpost all other groups.**Group/Create...***Action:*

Create

New Group Name:

solid_with_tetmesh

 Unpost All Other Groups*Entity Selection*

Solid 2 (the base of the fin)

Now, zoom in on the base of the fin using the following toolbar icon:



View Corners

The new solid should appear as follows.

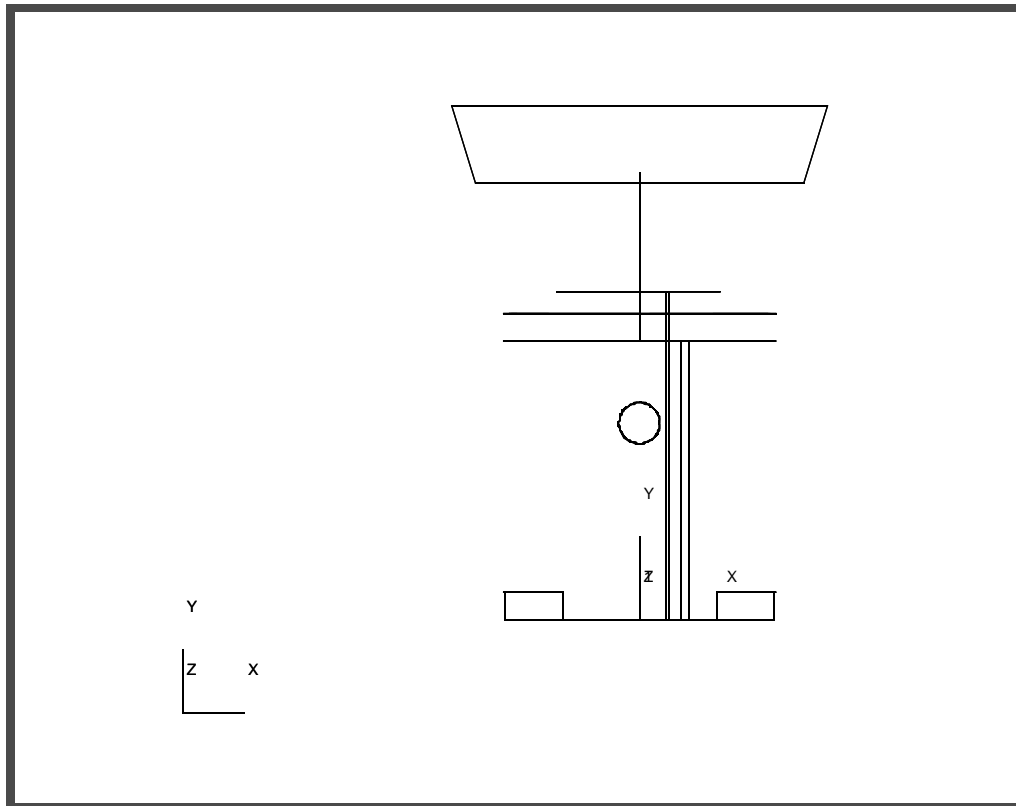

Now, mesh the solid base.

◆ **Finite Elements**

Action:

Object:

Method

Global Edge Length:

Mesher:

◆ **Tetmesh**

Input List:

16. Conduct a Mass Properties calculation on the base of the fin.

First, assign properties to the base of the solid.

◆ **Properties**

Action:

Create

Dimension:

3D

Type:

Solid

Property Set Name:

base_props

Input Properties...

The *Input Properties* form appears.

Material Name:

steel

OK

In order to select the tet elements of the new mesh, use the following entity select icon:



Solid Element

Select Members:

select all solid elements

Add

Apply

Now, create a group called **mesh**.

Group/Create...

Action:

Create

New Group Name:

mesh

■ **Unpost All Other Groups**

Entity Selection

Add All FEM

Apply

17. Perform a Mass Properties calculation on the base.

Tools/Mass Properties...

Action:

Show

Dimension:

3D

Define Region...

The *Region for Mass Properties* form appears.

Include:

FEM

Select Groups:

mesh

OK

■ **Create Princ. Coord. Frame**

Apply

This ends the exercise.