

WORKSHOP 4

Geometry Model of a 3-D Clevis

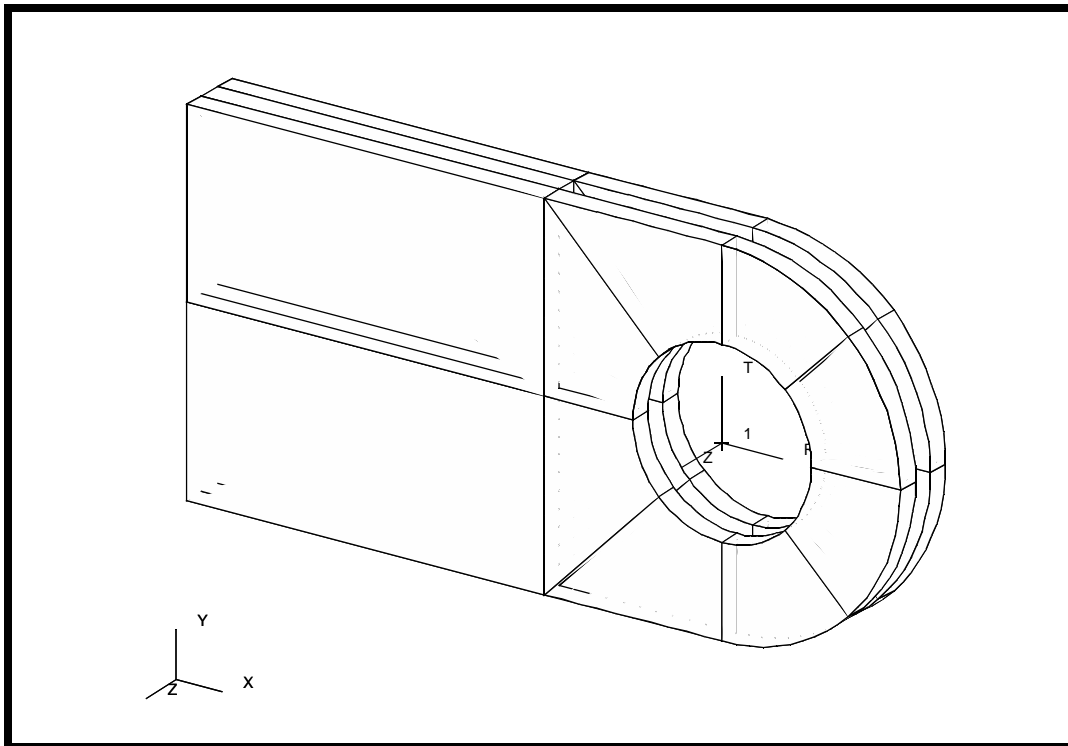

Objectives:

- Create a new database.
- Create geometry.
- Change the graphics display.



Model Description:

In this exercise you will create an analytic solid model of a clevis by defining MSC.Patran points, curves, surfaces, solids, and a user defined coordinate system. Throughout this exercise you will become more familiar with the use of the MSC.Patran select menu. You will also be introduced to another viewing method and shown how to change your model's render style. Shown below is a drawing of the model you will build and suggested steps for its construction.

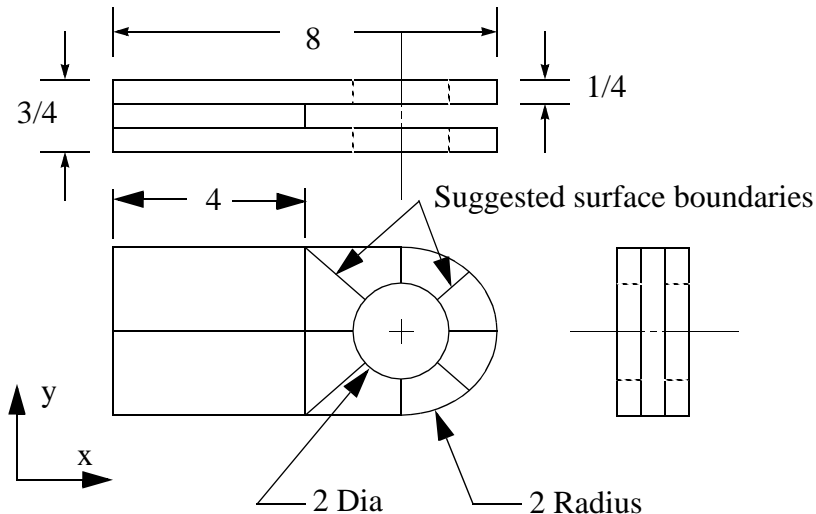

Suggested Exercise Steps:

- Create a new database and name it **Clevis.db**.
- Set geometry preference to PATRAN 2 convention.
- Create a surface model of the top half of the clevis as shown in the front view above. Place the center of the hole at [0,0,0].
- Create solids that represent the first third of the solid model's total width.
- Use the **Viewing/Transformations...** option to change the model's current view to an isometric view.
- Create the bottom half of your model by mirroring all of the solids about the y-axis mirror plane located at $y=0$.
- Create the remaining solids that represent the last two thirds of your model in the width direction (z-direction).
- Turn all the entity labels off and render your model in a hidden line render style.

Exercise Procedure:

Open a New Database

1. Open a new database and name it **clevis.db**.

File/New...

New Database Name

clevis

OK

New Model Preference

Tolerance

◆ Default

OK

2. Change the geometric preference to PATRAN 2 convention.

The **PATRAN 2 Convention** convention represents a special class of parameterized geometry known as parametric cubic. This option allows the user to create geometry that can be exported and imported into PATRAN 3 through the PATRAN 2 neutral files and IGES files.

Preferences/Geometry...

Geometric Representation

PATRAN 2 Convention

Solid Origin Location

◆ P3/PATRAN Convention

Apply

Cancel

3. Create a point on the inner radius of the hole in the clevis.

Click on the **Geometry** switch in the *Main Form*.

◆ **Geometry**

Action:

Create

Object:

Point

Method:

XYZ

Point Coordinates List

[1, 0, 0]

Apply

Create Points Using XYZ Method

In case you want to see the newly created point a little better, simply increase the point size through the **Display/Geometry** menu:

Display/Geometry...

Point Size:

Apply

Cancel

Also turn on the **Entity Labels**.

Display/Entity Color/Label/Render...

Show All Entity Labels

Apply

Cancel

- Use the point you just created to sweep 4 curves that will define the upper half of the radius of the hole in the clevis.

Action:

Object:

Method:

Total Angle

Curves per Point

Point List

Apply

If the **Auto Execute** button is on you do not need to press **Apply**

Creating a Curve Using the Revolve Method

Curves 1 through 4 can now be seen in the Viewport.

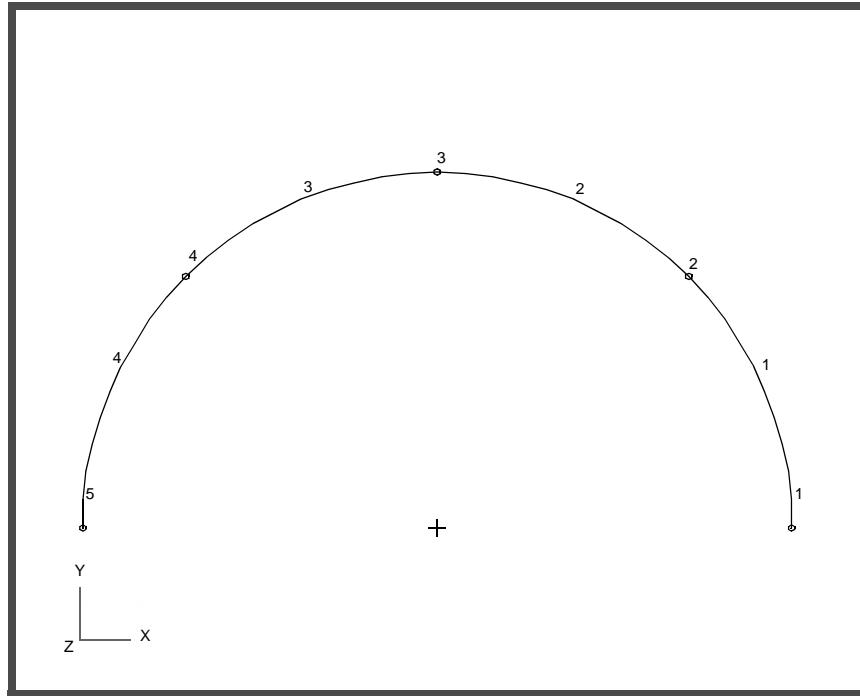

Translation using Curvilinear Transformation

- You will now use Curvilinear Transformation to create the outer radius of the lug by radially translating the curves that define a quarter of the hole.

To accomplish this you will first need to create a cylindrical coordinate frame located at the center of the hole.

<i>Action:</i>	Create
<i>Object:</i>	Coord
<i>Method:</i>	3Point
<i>Type:</i>	Cylindrical
Apply	

This process was rather simple, since the origin, Z-axis, and XZ plane of the desired coordinate system were already defined by default on the form.

Transform a Curve by Translation

<i>Action:</i>	Transform
<i>Object:</i>	Curve
<i>Method:</i>	Translate
<i>Type of Transformation</i>	◆ Curvilinear in Refer.CF

Refer. Coordinate Frame

Coord 1

Translation Vector

<1, 0, 0>

Curve List

Curve 1 2

Apply

Curves 5 and 6 appear in the viewport.

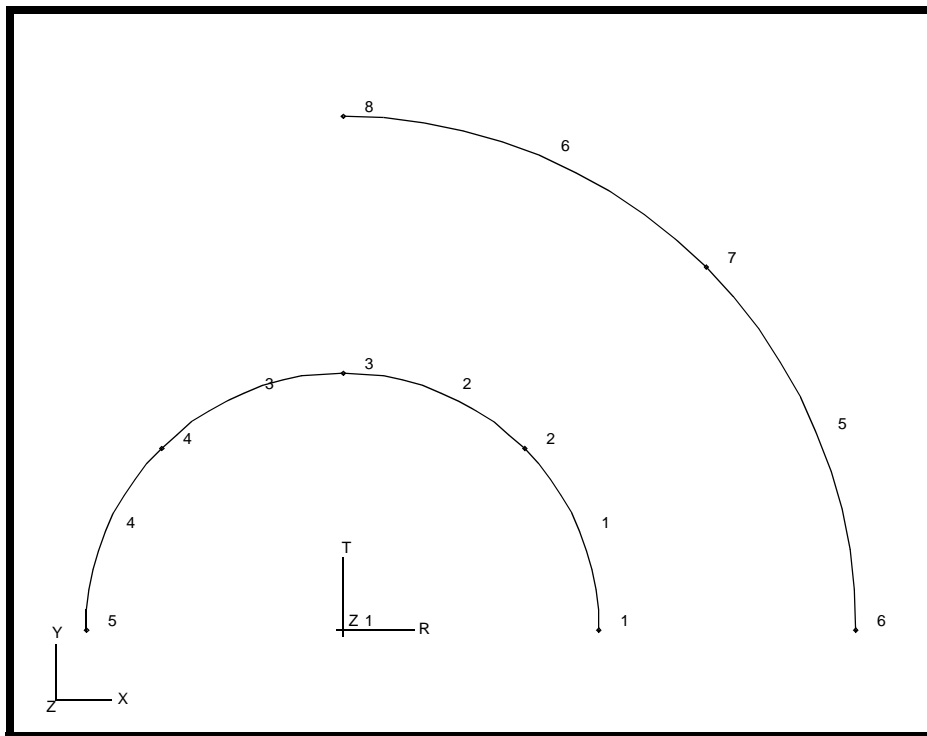

- You have now created all the curves that you will need to complete your clevis model. Next, you will create the necessary surfaces for the model. You will start by creating a 4x2 Surface that defines part of the upper half of the clevis body.

Create a Surface

Action:

Create

Object:

Surface

Method:

XYZ

Vector Coordinate List

<-4, 2, 0>

Create a Surface using the Curve Method

Origin Coordinate List

[-2, 0, 0]

Apply

Turn display lines on:



Display Lines

- The next series of Surfaces will be created using the Curve Method. This is very similar to the 2L option of Patran 2.5, but has been expanded to allow more flexibility. We will see why it is now called the *Curve* Method and not the *Line* Method.

Let's start on familiar ground: a surface between 2 Lines.

Action:

Create

Object:

Surface

Method:

Curve

Option:

2 Curve

Starting Curves List

Curve 1, 2

Ending Curve List

Curve 5, 6

In most MSC.Patran forms the default setting for the **Auto Execute** button is on. If the form executes before you have entered all the data correctly, the undo button will undo what you have just created. Turn off the **Auto Execute** button and redo your selection.

If the **Auto Execute** switch is off and the curves have been selected, hit:

Apply

To create the next surface you will use the *Select Menu* to help you define an existing curve and surface edge as the boundaries of the new surface.

Starting Curves List

Curve 4

Next, click in the *Ending Curve List* databox, and then select the Surface Edge icon on the select menu.



In the viewport, pick the edge of **Surface 1** as shown in the figure below.

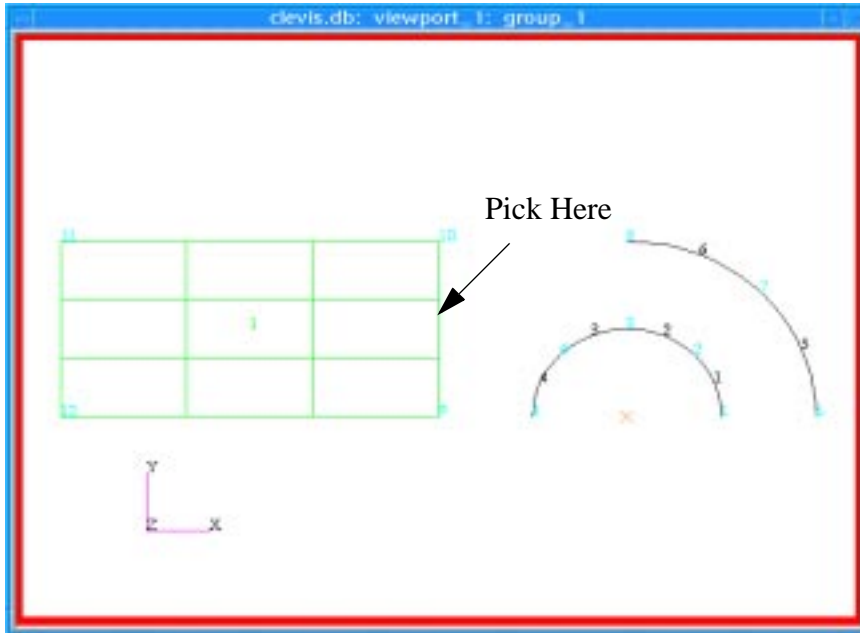

If the **Auto Execute** switch is off, click on the **Apply** button to create the surface. **Surface 4** appears in the Viewport.

To create the final surface, you will utilize the *Select Menu* to define the ending curve as a line between two defined Points.

Change the *Starting Curve List* to **Curve 3**. Remember to select the **curve** icon from the *Select Menu* before you select **Curve 3**.



Starting Curves List

Curve 3

Click in the *Ending Curve List* databox. Select the 2-point icon in the *Select Menu*.

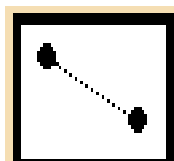

2-point icon

In the viewport, pick **Points 8** and **10** as shown below.

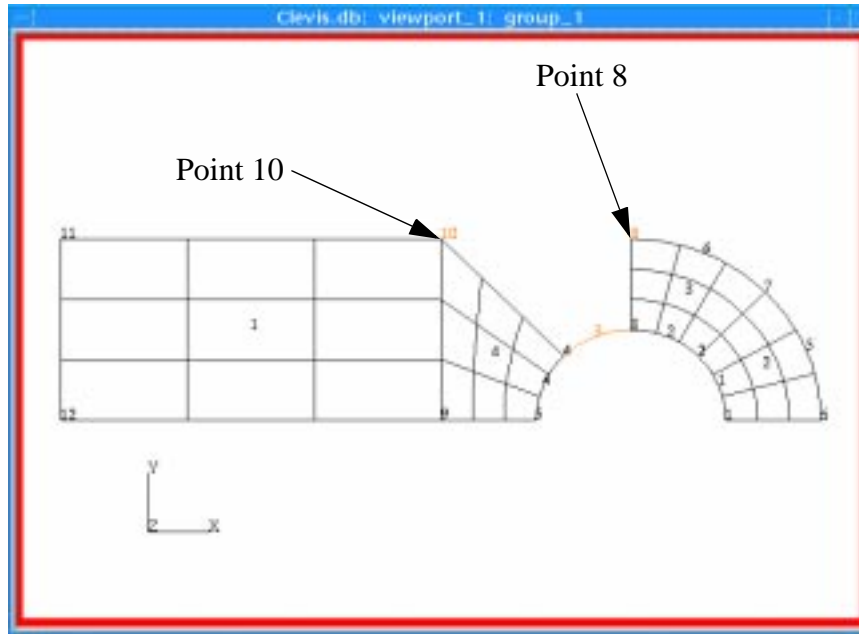

Patran will evaluate the location of **Points 8** and **10** and create a theoretical curve between them. This defines the second curve. Click on:

Apply

Surface 5 appears in the Viewport.

8. You will now use the Surfaces you have just created as patterns to define solids (3-dimensional entities).

Action:

Create

Object:

Solid

Method:

Normal

Thickness

0.25

Surface List

(Select all on screen)

Surface 1:5

Apply

Solids 1 through **5** will appear in your Viewport.

- To obtain a more descriptive view of the solids you will now change the model's view by using the new interface to the Transformations View option.

View using the Transformation Option

Click on **Viewing** in the *Main Form* and select **Transformations..** from the pull-down menu. The following form appears.

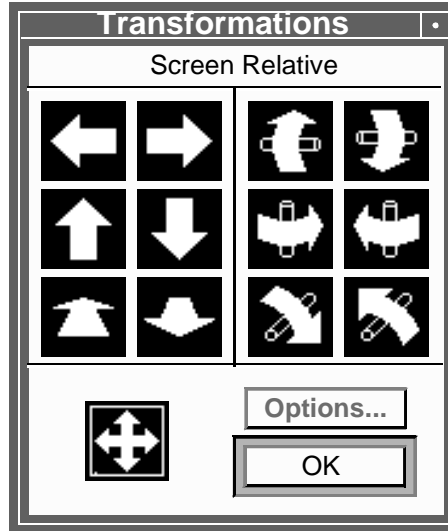

Click once on



and once on



to rotate the view 30° about the screens y-axis and 30° about the screens x-axis respectively. Your model should now be oriented similar to the one shown below (the picture below has display lines on). Click on the **OK** button to close the *Transformation* form.

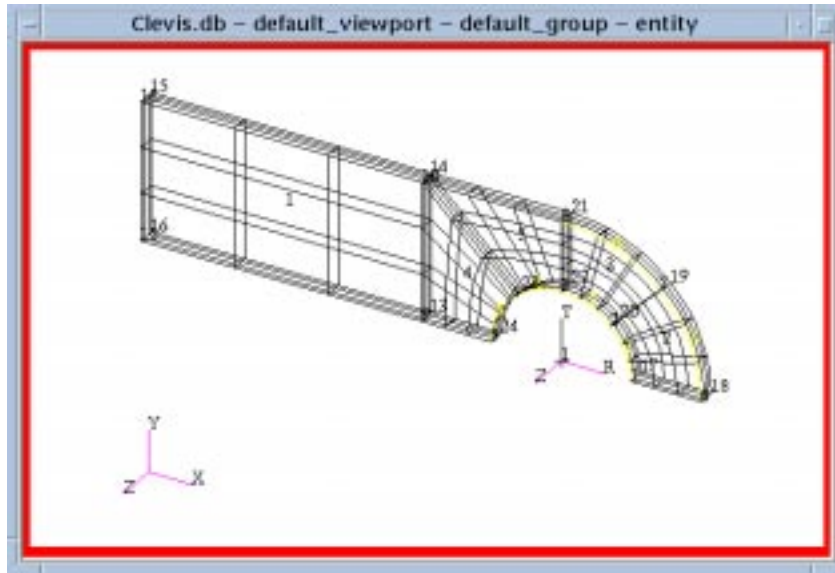

You will now perform a series of transformations on the solids to create the remainder of your geometry model.

10. Create the lower half of this part of the clevis model.

Transform Using Mirror Method

Action:

Transform

Object:

Solid

Method:

Mirror

Click in the *Define Mirror Plane Normal* databox. Notice that the mirror plane is no longer limited to solely X, Y, or Z and that now mirroring can be performed about any arbitrary mirror normal vector defined by a base and a tip

The mirror plane for this model is the global XZ-plane. The vector perpendicular to that plane points in the global Y-direction. Notice that global Y is aligned with the '2' direction of your local coordinate

frame 1. To use the 2-axis to identify the orientation of the mirror plane, select the icon indicating **coordinate axis 2** from the *Select Menu* as shown below.

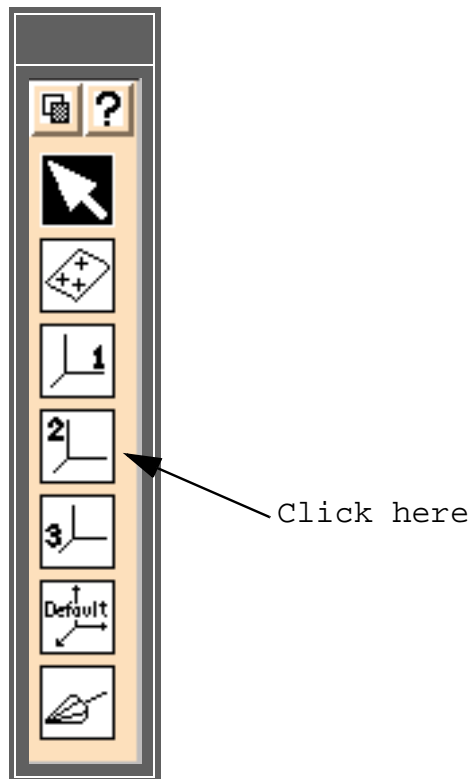

Next, select **Coordinate Frame 1** in your viewport.

Click in the *Solid List* databox of the *Geometry* form and select all solids in the Viewport.

Solids 6 through 10 appear in the Viewport as shown below.

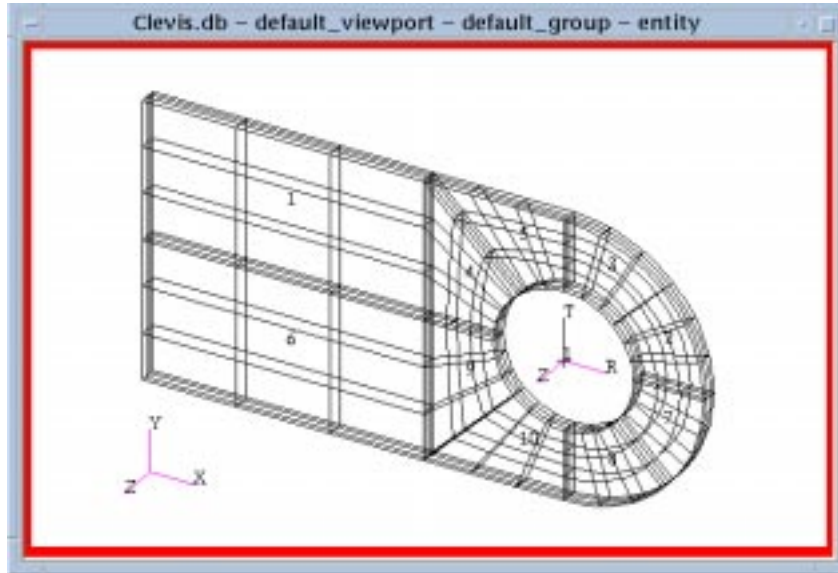

**Transform
using the
Translate
Method**

11. The remaining solids will be created using the translate method.

<i>Action:</i>	Transform
<i>Object:</i>	Solid
<i>Method:</i>	Translate
<i>Translation Vector</i>	< 0, 0, -.25 >
<i>Repeat Count</i>	2

Translating the solids in two steps is the trick for creating congruent geometry which is needed for the meshers.

<i>Solid List</i>	Solid 1, 6
Apply	

Solids 11 through 14 appear in the Viewport.

Your last construction step is to translate copies of the solids that surround the hole to create the final solids.

Click in the *Translation Vector* databox.

From the *Select Menu* pick the tip and base points icon.

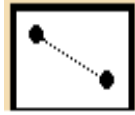

To define the translation vector, pick **Point 10** then **Point 40** as shown below. Use **Select Corners** icon from the toolbar.



Select Corners



Fit View

After selecting the points use **Fit View** icon to zoom out.

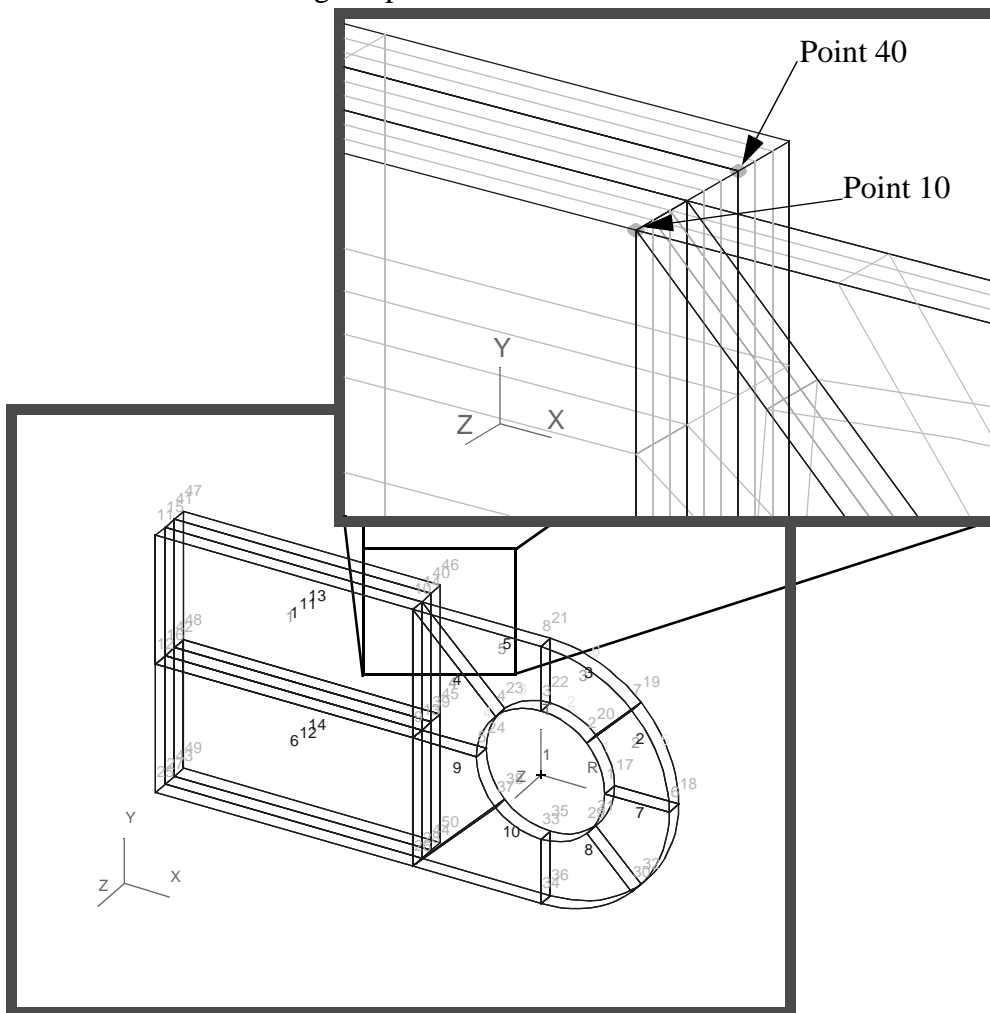

Change the *Repeat Count* to **1**. Click in the *Solid List* databox. In your Viewport, select all solids that surround the hole.

Solids 15 through 22 appear in the viewport. The model is now complete. Next you will practice changing the rendering style of your model.

12. To complete this exercise, you will close the database.

Close the Database

File/Quit...

This will exit MSC.Patran and close your file. Do not delete the database from your directory since you will use it for future exercises.