

WORKSHOP 10

Time Dependent Boundary Conditions

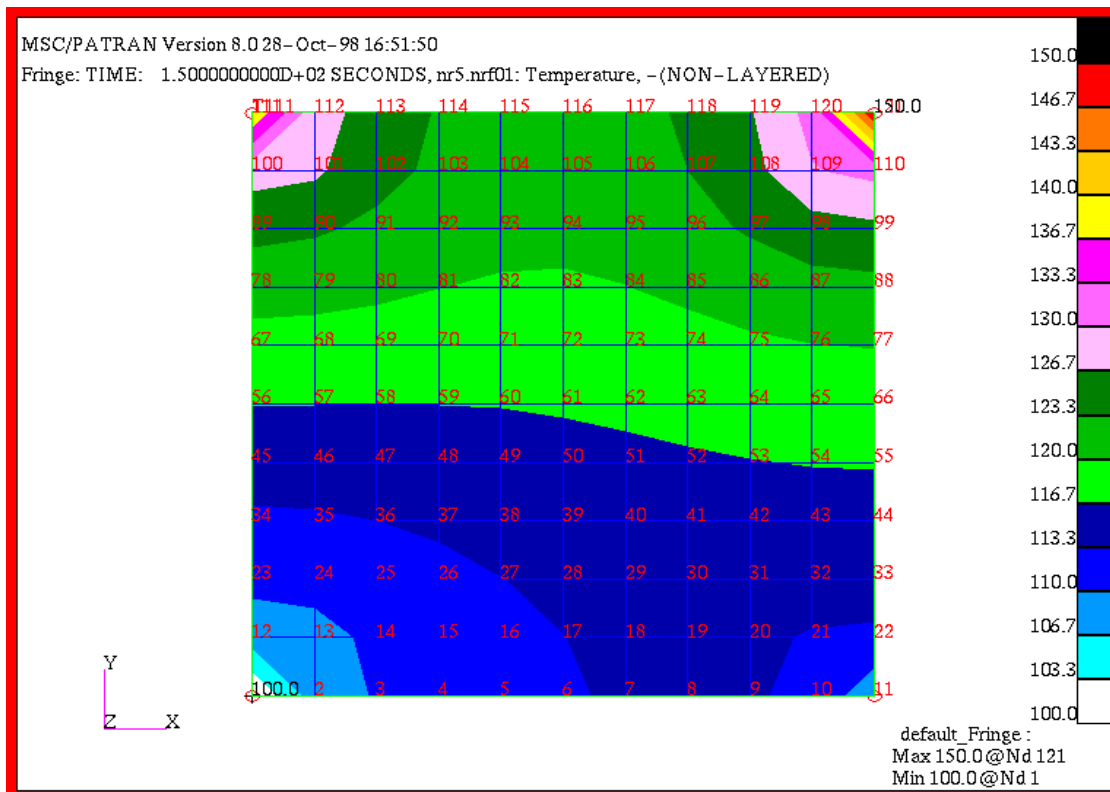

Objective:

- Model an aluminum plate.
- Use microfunctions to apply time dependent boundary conditions to the plate corners.
- Run a transient analysis to produce time dependent results.

Model Description:

In this exercise you will define MACROs and microfunctions. MACRO definitions are edited into a **template.dat.apnd** file which you create in the same directory as your database.

MACRO definitions link Template ID's (TID's) which are applied in the Loads/BCs form to Microfunction ID's (MFID's) which are defined in the Fields form. A microfunction can be a function of time or various temperature functions. This provides a mechanism for defining time or temperature varying heat load or temperature boundary conditions. Only constant or spatially varying loads or boundary conditions can be defined directly in the Loads/BCs forms.

In this exercise we will sample three of the available microfunctions: a sine wave, a flip-flop function and a linearly interpolated data table. These functions are applied to three of the four corners of an aluminum plate modelled from shell elements. The fourth plate corner will have a constant boundary temperature.

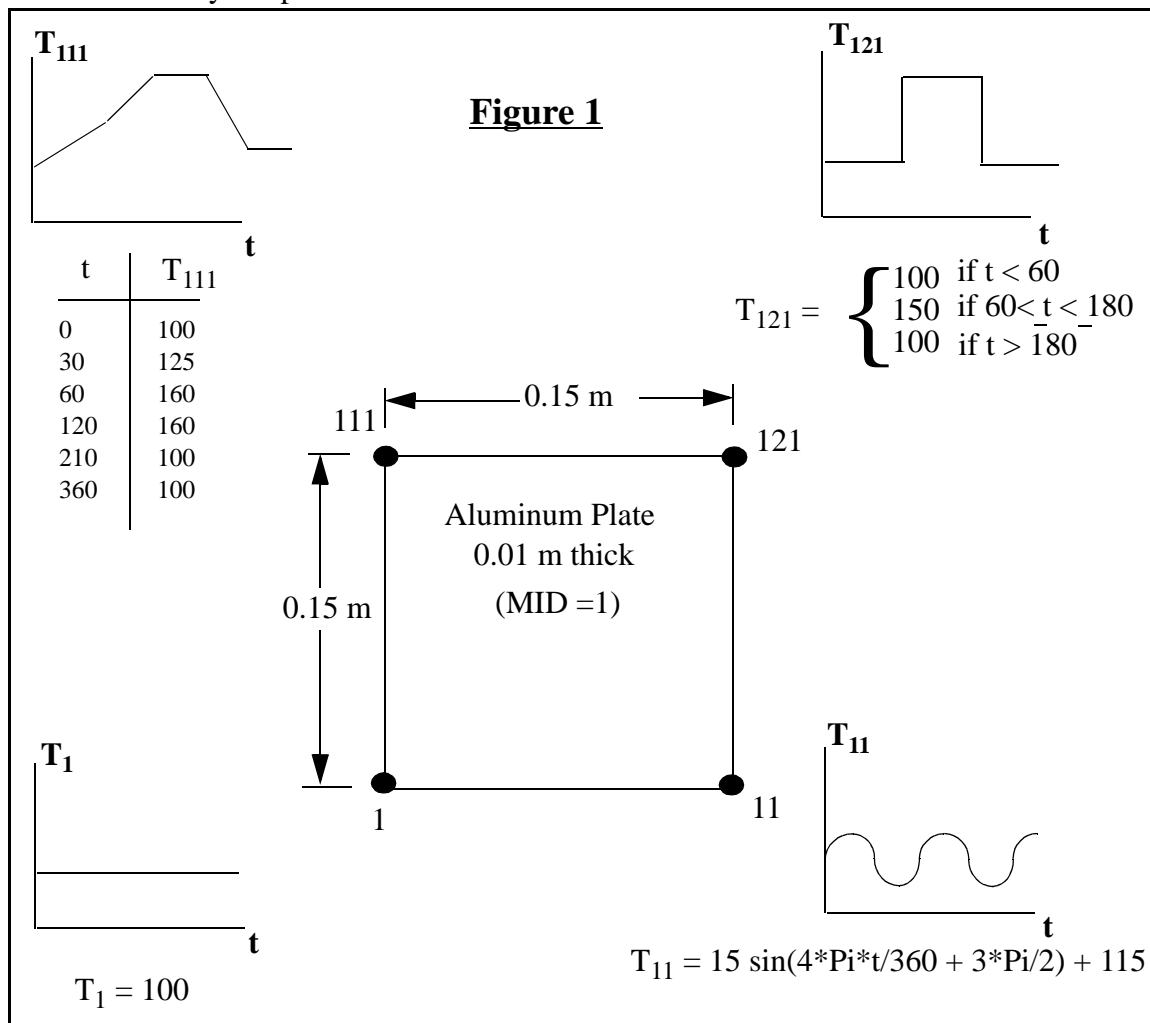

Exercise Overview:

- Create a new database named **exercise_10.db**. Set *Tolerance* to **Default**, and the *Analysis Code* to **MSC/THERMAL**.
- Create a 0.15m x 0.15m plate surface.
- Mesh the surface with an IsoMesh of quad4 elements, global edge length of 0.015.
- Apply element properties to the quad4's defining them as shell elements having a material name (MID) of 1 and a thickness of 0.01m.
- Create 3 time dependent microfunctions using **Fields** and **Create/Non Spatial/General**.
- Define 4 temperature boundary condition in Loads/BC's, 1 fixed nodal temperature in the lower left corner of the plate and 3 variable nodal temperatures on the remaining corners.
- Use the new **Analysis/Build Template** to create the MACRO definitions in the template.dat .apnd file.
- Prepare and submit the model for analysis specifying that it is a transient analysis from t=0s to t=360s with output each 30s, that the global initial temperature is 100°C, and that all calculations and output should be °C.
- Read the results files using Shareware and plot results for several time steps. Do not delete the database from your directory since it will be used in a future exercise.
- **Quit** MSC.Patran.

Exercise Procedure:

Open a new database

1. Open a new database named **exercise_10.db**.

Within your window environment change directories to a convenient working directory. Run MSC.Patran by typing **p3** in your xterm window.

Next, select **File** from the *Menu Bar* and select **New...** from the drop-down menu. Assign the name exercise_10.db to the new database by clicking in the *New Database Name* box and entering **exercise_10**.

Select **OK** to create the new database.

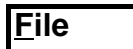

New...

New Database Name

exercise_10

OK

MSC.Patran will open a Viewport and change various *Main Form* selections from a ghosted appearance to a bold format. When the New Model Preferences form appears on your screen, set the *Tolerance* to **Default**, and the *Analysis Code* to **MSC/THERMAL**. Select **OK** to close the New Model Preferences form.

Tolerance

◆ Default

Analysis Code

MSC/THERMAL

OK

2. Create a 0.15m x 0.15m plate surface.

Select the **Geometry Applications** radio button. Create a surface using the following *Action*, *Object*, and *Method*. Click in the appropriate list boxes to edit the default values and change them to values listed below.

Create plate geometry

◆ Geometry

Create/Surface/XYZ

Vector Coordinate List

<0.15 0.15 0>

Apply

The resulting model is shown below.

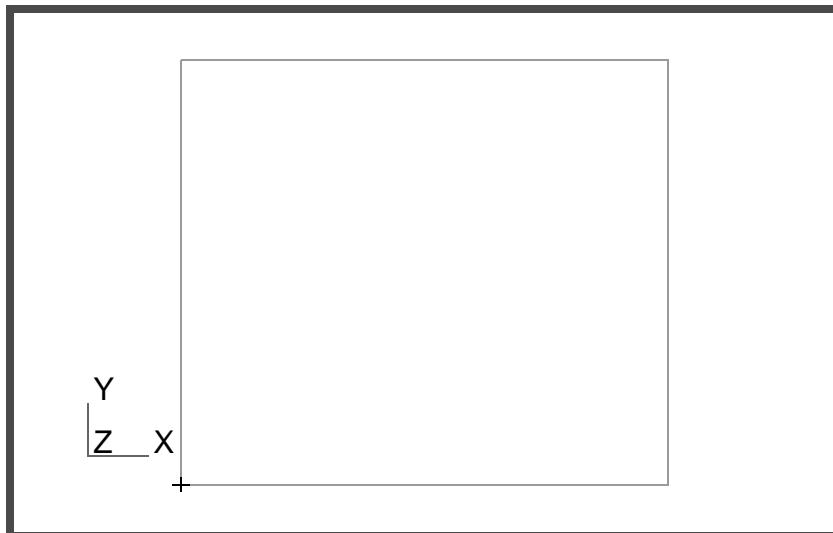

IsoMesh the surfaces

3. Mesh the surface with an IsoMesh of quad4 elements, global edge length of 0.015.

Select the **Finite Elements Applications radio button**. Set the *Action*, *Object*, and *Type* to **Create/Mesh/Surface**. Change the *Global Edge Length* to **0.015** and select **Surface 1** for inclusion in the *Surface List*.

◆ Finite Elements

Create/Mesh/Surface

Global Edge Length

0.015

Surface List

<click on Surface 1 in the viewport>

Apply

Use the *Tool Bar Label Control* icon to turn on node labels **only**.

First select



then



Close

The display should now appear as shown below.

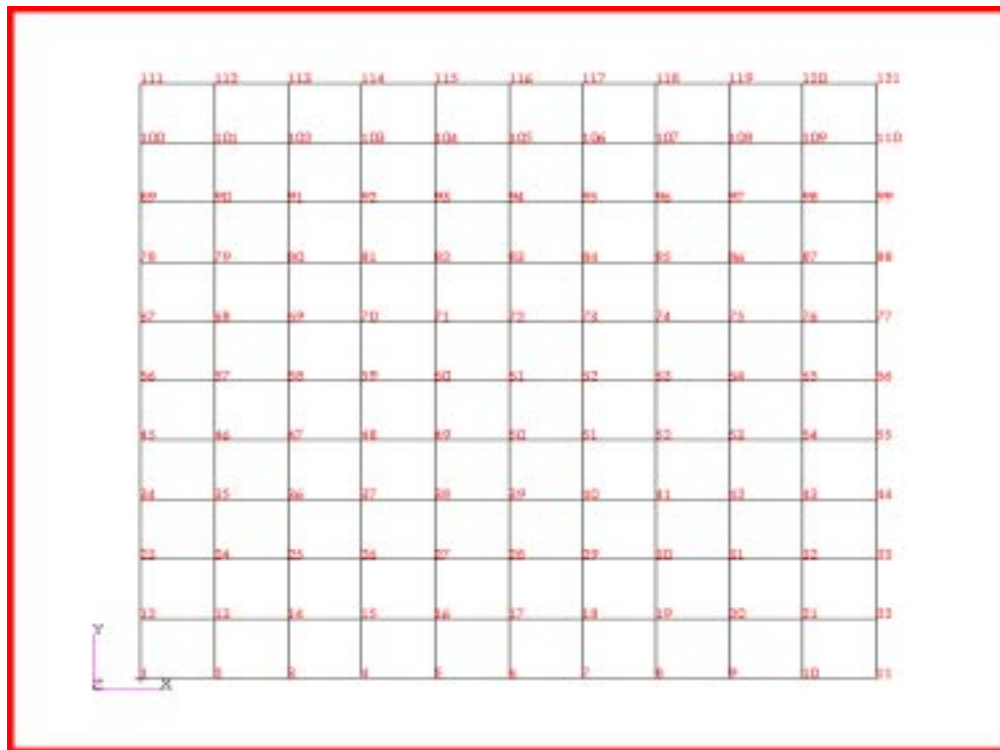

- Apply element properties to the **Quad4**'s defining them as shell elements having a *Material Name* (MID) of **1** and a thickness of **0.01m**.

Apply element properties

Select the **Properties Applications** radio button. Set the *Action*, *Dimension*, and *Type* to **Create/2D/Shell**. Enter *Property Set Name* **Prop1**. Select the *Input Properties...* box. Click in the *Material Name* box and enter **1**. Enter **0.01** in the *Shell Corner Thickness* list box. Select **OK** to close the form. Click in the *Select Members* box and select Surface 1 in the viewport. Select **Add** then **Apply** in the Element Properties form to complete the element property definition.

◆ Properties	
Create/2D/Shell	
Property Set Name	Prop1
Input Properties...	
Material Name	1
Shell Corner Thickness	0.01
OK	
Select Members	<select Surface 1 in the viewport>
Add	
Apply	

- Create 2 time dependent microfunctions using **Fields** and **Create/Non Spatial/General**.

Create micro-functions

Microfunctions are created in the *Fields* form using the *Action/Object/Method* **Create/Non Spatial/General**. After selecting **Input Data**. The General Field Input Data form will show the complete list of microfunctions in the *Select Function Term:* list box.

Figure 1 contains the data required for entry into the various microfunction forms. The entries and selection below will guide you through the process of creating the microfunctions. An image of each completed microfunction form is included to facilitate microfunction entry.

◆ Fields	
Create/Non Spatial/General	
Field Name	Tsine

Input Data...

Select Function Term	mfid_sine_wave
Micro Function ID	11
P1 Value	15.0
P2 Value	0.034907
P3 Value	4.71239
P4 Value	115.0

OK

OK

Apply

The Micro Function form should appear as shown below.

Micro Function: Sine Wave

Define Micro Function
Option 3
Sine Wave
 $F(X) = P1 * SIN(P2 * X + P3) + P4$

Micro Function ID (MFID)	Micro Function Option
11	3
Micro Function Description	
Independent Variable Type	<input type="checkbox"/> Reciprocal Micro Function
Time	

P1 Value	P2 Value
15	0.034907
P3 Value	P4 Value
4.712389	115.0

OK

Defaults

Cancel

Field Name	Tflip_flop
Input Data...	
Select Function Term	mfid_flip_flop
Micro Function ID	121
P1 Value	60.0
P2 Value	180.0
P3 Value	150.0
P4 Value	100.0
OK	
OK	
Apply	

The Micro Function form should appear as shown below.

Micro Function: Flip Flop Function

Define Micro Function
 Option 15
 Flip Flop Function
 If $P1 \leq X < P2$, Then $F(X) = P3$
 Else $F(X) = P4$

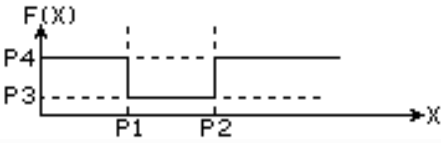

Microfunction ID (MFID) 121	Microfunction Option 15
Microfunction Description <div style="border: 1px solid gray; height: 20px;"></div>	
Independent Variable Type Time	<input type="checkbox"/> Reciprocal Microfunction

P1 Value 60.0	P2 Value 180.0
P3 Value 150.0	P4 Value 100.0

Apply boundary conditions

- Define 4 temperature boundary condition in Loads/BCs, 1 fixed nodal temperature in the lower left corner of the plate and 3 variable nodal temperatures on the remaining corners.

Begin applying boundary conditions. Select the **Loads/BCs Applications** radio button. Create a fixed **100°C** nodal boundary temperature named **T1**. In the Input Data form define the fixed temperature. In the Select Applications Region form pick **Node 1** located in the lower left corner of the plate.

◆ Loads/BCs	
Create/Temperature/Nodal	
Option:	Fixed
New Set Name	T1
Input Data...	
Fixed Temperature	100.0
OK	
Select Application Region...	
Geometry Filter	◆ FEM
Select Nodes	<select Node 1>
Add	
OK	
Apply	

Create a variable boundary temperature named **T11** with *Template Id 2* in the Input Data form. In the Select Applications Region form pick **Node 11** located in the lower right corner of the plate.

◆ Loads/BCs	
Create/Temperature/Nodal	
Option:	Template
New Set Name	T11
Input Data...	
Template ID	2
OK	
Select Application Region...	

Select Nodes

<select Node 11>

Add

OK

Apply

Repeat these steps for *New Set Name* **T121** with *Template ID* **3** on **Node 121**.

New Set Name

Input Data...

Template ID

OK

Select Application Region...

Select Nodes

<select Node 121>

Add

OK

Apply

Create the last nodal LBC using the new *Time Table option* which provides for creating the LBC entirely from the LBC form.

◆ **Loads/BCs**

Create/Temperature/Nodal

Option:

New Set Name

Input Data...

Name - Temperature Table

Description - Temperature Table

Time Input Value

Temperature Input Value

Repeat the Time and Temperature Input Values for the following pairs.

	Time	Temperature
2	30.0	125.0
3	60.0	160.0
4	120.0	160.0
5	210.0	100.0
6	360.0	100.0

OK

Select Application Region...

Select Nodes

<select Node 111>

Add

OK

Apply

With boundary conditions applied the model should appear as shown below

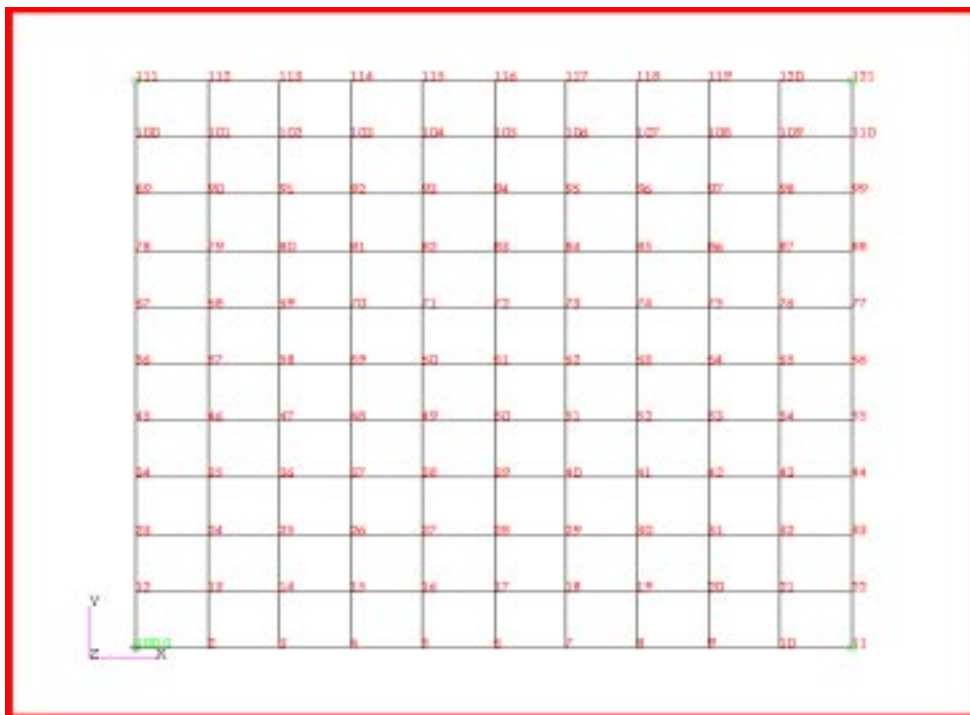

- Use the new **Analysis/Build Template** to create the MACRO definitions in the template.dat.apnd file.

Beginning with MSC.Patran THERMAL V8, the template.dat.apnd file can be created from within the MSC.Patran interface. The ANALYSIS/BUILD TEMPLATE forms allow creating and editing all of the required templates.

Use the following chart to help you define the MACRO functions for the temperature boundary conditions assigned to Nodes 11 and 121.

Create
template.dat.
apnd file

Table 1:

TID#	Node 1	Node 2	scale_factor	mfid#
2	0	0	1	11
3	0	0	1	121

Note: Nodes 1 and 2 are set to zero since the argument is time.

◆ Analysis

Build Template

Create Template File...

Create/MACRO/Data Entry

MACRO ID

MFID's

Apply

A Template Entries form will appear, close it.

Cancel

MACRO ID

MFID's

Apply

Write File...

In the File Option form, **template.dat.apnd** should be the default name in the *File Name* input box.

OK

Cancel

Cancel

Shown below is the final form of the **template.dat.apnd** file created for this exercise.

MACRO 2 1 0 0 1.0

11

MACRO 3 1 0 0 1.0

121

8. Prepare and submit the model for analysis.

Select the **Analysis Applications radio button** to prepare the analysis. Select the parameter forms reviewing and changing the settings as shown below. The analysis is submitted by selecting **Apply** in the Analysis form.

◆ Analysis

Analyze/Full Model/Full Run

Solution Type...

Select Thermal Solution

◆ 1, Transient Run

OK

Solution Parameters...

Calculation Temperature Scale

◆ Celsius

Run Control Parameters...

Stop Time

360.0

Initial Temperature =

100.0

OK

OK

Output Requests...

Units Scale for Output Temperatures

◆ Celsius

Prepare and run analysis

Print Interval Controls...

Initial Print Interval

OK

OK

Apply

9. Read the results files using **Utilities** and plot results for several time steps. Do not delete the database from your directory since it will be used in a future exercise.

Read and plot results

From within MSC.Patran the only indication that the analysis has successfully finished is the existence of **nrX.nrf.01** ("x" will range from 1-12) results files in a subdirectory one level below your working directory.

P3 was initiated from a working directory which contained the exercise_010.db database. Applying the analysis created a new subdirectory with the same name as the *Job Name*, exercise_10/. By using **Read Result** in the Analysis form and Selecting **Results File...** you can filter down to the *Job Name* subdirectory and check for the existence of a results file

Utilities provides a results reader under **Thermal** which facilitates reading the results of transient runs. If you do not have Shareware installed or is unavailable then skip to the instructions below which tell you how to read the results from the Analysis form.

Utilities

Thermal

Thermal Results Reader...

Disclaimer

OK

Directories

Filter

All your **nr.nrf.01** files should appear in the *Selected Files* list box. Edit the end of the path and file in the *Selected File* box to end in nr*.

Selected File

All the files will be read into the database. Since the analysis does not involve convection template ID's, the results template that is used in reading the files detects that there are no such entries and creates a warning message for each occurrence. This warning is irrelevant to this analysis. When the warning messages cease. Click **OK** in the Warning form.

Select **Close** to exit the **Utilities**.

Warning

[OPTIONAL METHOD follows. Use only if necessary]

If for whatever reason **Utilities** are unavailable you can use the standard MSC.Patran method of reading the results files. However, a Global Variable for Time will not be created in the Result Cases. This will adversely affect the animation subsequently created in Exercise 19.

◆ Analysis

Directories

Available Files

Files

Once you have selected a *Results Template* you can repeat the **Select Results File...** step and hit **Apply** on the Read Results form without again selecting a template.

Available Files

nr1.nrf.01

OK

Apply

Repeat these steps for each **nr#.nrf.01** file until all results are read.

[END OPTIONAL METHOD]

After results are read in by either method, plot the results. To plot the results use the **Results Application radio button**. Select results for t=150s.

◆ Results

Create/Quick Plot

Select Result Cases

TIME: 1.500000000D+02 S...

Select Fringe Result

Temperature,

Select the *Fringe Attributes* icon.



Display:

Element Edges

Label Style...

Label Format:

Fixed

Significant figures

4 <use slider bar>

OK

Apply

The posted results are for t=150s. The model should now appear as shown on the front panel of this exercise. Feel free to post results from other times to verify your results.

Do not delete the database when you finish this exercise it will be used in a future exercise. In that exercise we will animate the results to display the model's behavior through time.

10. Quit MSC.Patran

To stop MSC.Patran select **File** on the *Menu Bar* and select **Quit** from the drop-down menu.

Quit
MSC.Patran

