

---

**LESSON 14**

*Hertz Contact Problem*

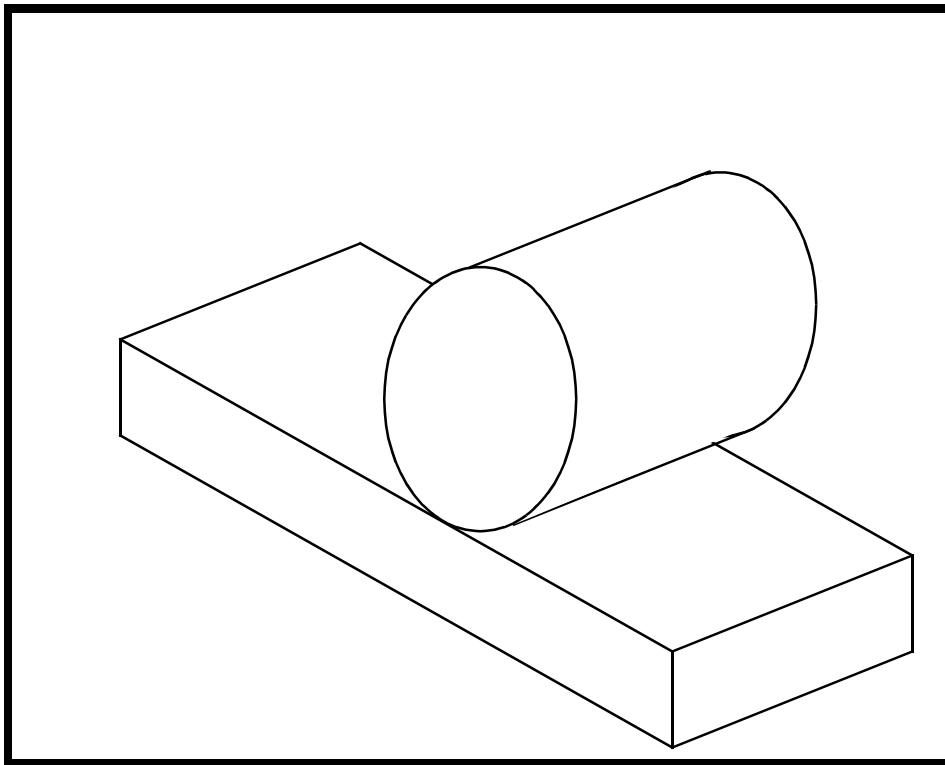

**Objectives:**

- Use of contact pair approach.
- Post-processing of the results.



## Model Description:

In this example problem, a steel cylinder with a radius of 5" is pressed against a 2" deep aluminum base. The problem is linear except the contact condition at the base which is modeled using the contact pair approach. The problem is similar to the Hertz contact problem. (see Timoskenko and Goodier, 1951)

In this problem you will create the geometry. Then you will proceed to mesh, load and analyze the problem. The steel material properties have an Elastic Modulus of 30E6 and a Poisson's ratio of 0.30 and the aluminum properties have an Elastic Modulus of 10E6 and a Poisson's ratio of 0.33. The contact and force application will be modeled, where the cylinder and base plate will come into contact, and a load of 100,000 lb/ inch depth will be added to create the hertz contact condition.

## Suggested Exercise Steps:

- Create a new database and name it **hertz.db**.
- Create the geometry for the cylinder and the base plate.
- Specify material and element properties.
- Specify boundary conditions for symmetry, base and contact confirmation. Also specify loadings for the cylinder.
- Analyze the model and inspect the contact stresses.

---

## Exercise Procedure:

1. Open a new database. Name it **hertz**.

### File/New ...

Database Name:

hertz.db

OK

Change the *New Analysis Preference* form to **MSC.Marc**.

Analysis Code:

MSC.Marc

OK

2. Create the geometry for the cylinder and the base plate.

First create a group that contains the cylinder and name it **cylinder**

### Group/Create...

New Group Name:

cylinder

■ **Make Current**

Group Contents:

Add Entity Selection

Apply

Cancel

■ **Geometry**

Action:

Create

Object:

Curve

Method:

XYZ

Vector Coordinates List:

<5, 0, 0>

Origin Coordinates List:

[0, 0, 0]

Apply

Action:

Create

Object:

Surface

Method:

Revolve

<i>Axis:</i>	<input type="text" value="Coord 0.3"/>
<i>Total Angle:</i>	<input type="text" value="-90"/>
<i>Offset Angle:</i>	<input type="text" value="0.0"/>
<i>Curve List:</i>	<input type="text" value="Curve 1"/>
<input type="button" value="Apply"/>	

Repeat procedure to create a 180 degree arc with two surfaces.

<i>Total Angle:</i>	<input type="text" value="-90"/>
<i>Offset Angle:</i>	<input type="text" value="-90"/>
<i>Curve List:</i>	<input type="text" value="Curve 1"/>
<input type="button" value="Apply"/>	

Now create a group for the base plate.

**Group/Create...**

<i>New Group Name:</i>	<input type="text" value="plate"/>
<input checked="" type="checkbox"/> <b>Make Current</b>	
<i>Group Contents:</i>	<input type="text" value="Add Entity Selection"/>
<input type="button" value="Apply"/>	
<input type="button" value="Cancel"/>	

**Geometry**

<i>Action:</i>	<input type="text" value="Create"/>
<i>Object:</i>	<input type="text" value="Surface"/>
<i>Method:</i>	<input type="text" value="XYZ"/>
<i>Vector Coordinates List:</i>	<input type="text" value="&lt;16, -2, 0&gt;"/>
<i>Origin Coordinates List:</i>	<input type="text" value="[-8, -5.1, 0]"/>
<input type="button" value="Apply"/>	

3. Post cylinder geometry.

---

Post only the geometry for the cylinder.

**Group/Post...**

Select Groups to Post:

cylinder

Apply

Cancel

4. Create mesh seeds for the cylinder.

◆ **Elements**

Action:

Create

Object:

Mesh Seed

Method:

One Way Bias

Number:

22

L2/L1:

-5

Select the curved edge on the bottom right of the cylinder

Curve List:

bottom right curve  
(see Figure 14.1)

Repeat the above steps with the bottom left curve setting **L2/L1 = 5** and **Number = 22**.

Repeat the above steps for the vertical centerline with **L2/L1 = -2** and **Number = 22**.

Figure 14.1 - Mesh seed locations for cylinder

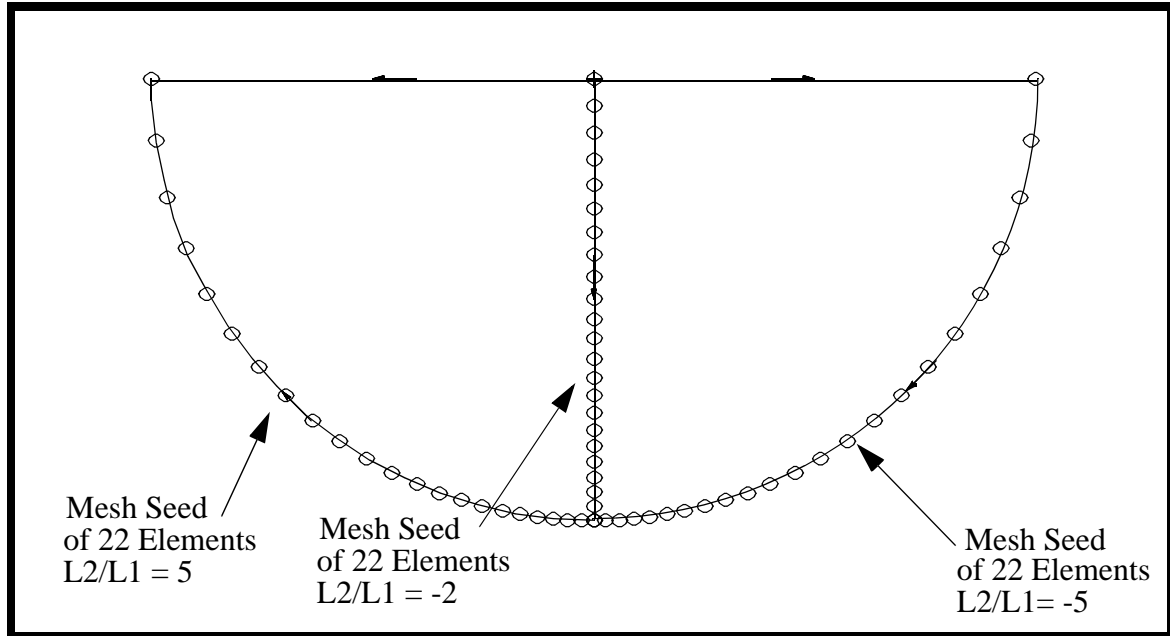

5. Mesh the surface with **Quad4** elements.

*Action:*

**Create**

*Object:*

**Mesh**

*Type:*

**Surface**

*Element Topology:*

**Quad4**

*Surface List:*

all posted surfaces  
(Surface 1 & 2)

**Apply**

Your model should now look like the one shown in Figure 14.2:

**Figure 14.2 - Meshed surface representing cylinder**

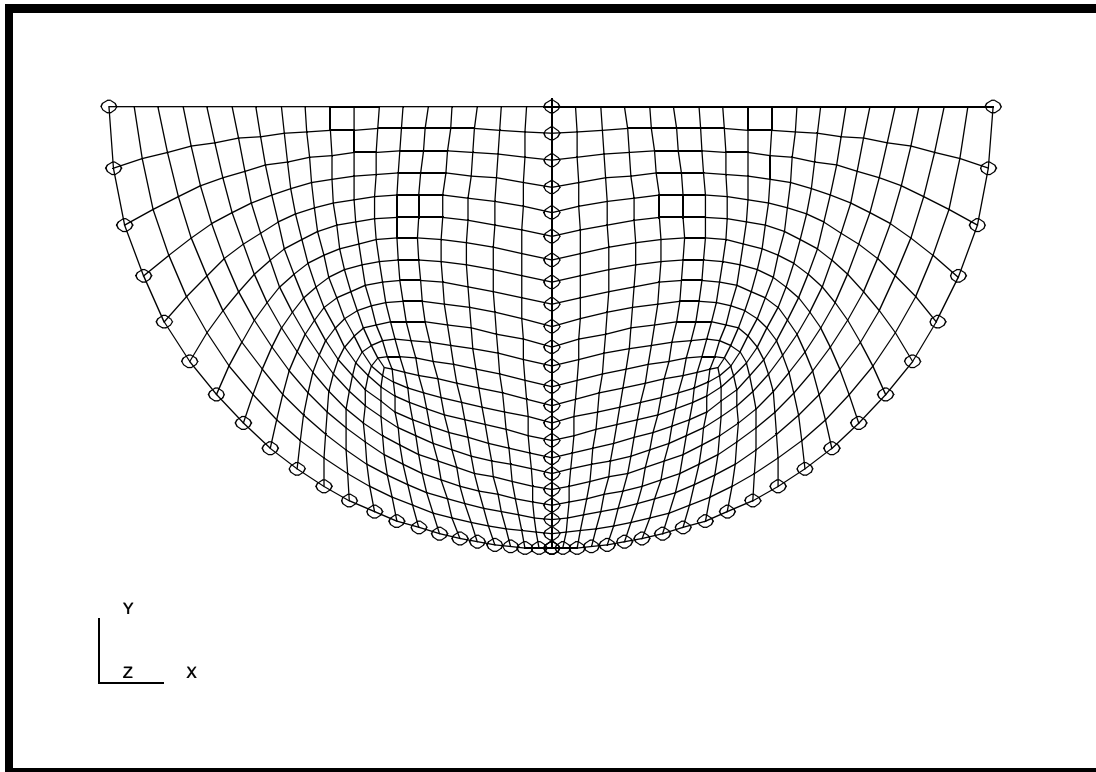

6. Post only the base plate geometry.

**Group/Post...**

Select Groups to Post:

plate

Apply

Cancel

7. Create mesh seeds for the plate.

First seed the top edge of the plate surface.

■ **Elements**

Action:

Create

Object:

Mesh Seed

Method:

Two Way Bias

Number:

44

L2/L1:

-5

*Curve List:*

Then seed the side of the plate.

*Action:*

*Object:*

*Method:*

*Number:*

*L2/L1:*

*Curve List:*

**Figure 14.3 - Mesh seed locations for plate**

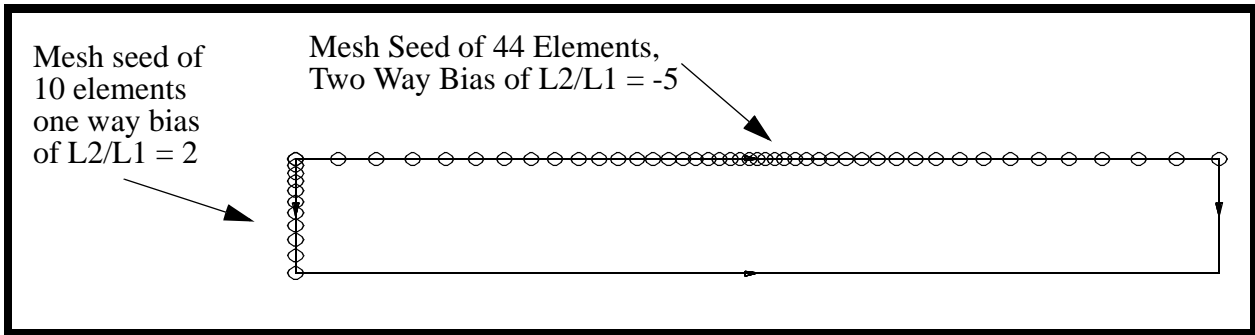

8. Mesh the plate surface with **Quad4** elements.

*Action:*

*Object:*

*Type:*

*Element Topology:*

*Surface List:*

Your model should now look like the one in Figure 14.4:

**Figure 14.4 - Meshed surface representing plate**

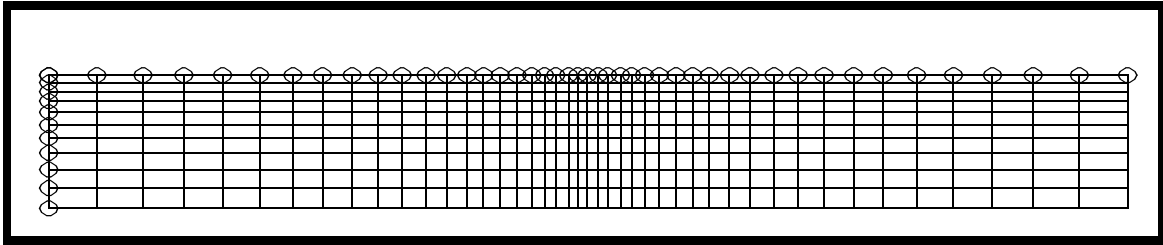

9. Create a new group **fem**.

This group will have all the finite elements for the entire model in it.

**Group/Create...**

*New Group Name:*

**fem**

■ **Make Current**

■ **Unpost All Other Groups**

*Group Contents:*

**Add All FEM**

**Apply**

**Cancel**

10. Equivalence the mesh.

*Action:*

**Equivalence**

*Object:*

**All**

*Method:*

**Tolerance Cube**

**Apply**

11. Verify element normals.

Since this is a 2-D plane strain model, the normals will need to be pointing in the positive **Z** direction. To assist you in reversing element normals, we will display the element normals right on the elements.

*Action:*

**Verify**

*Object:*

**Element**

*Test:*

**Normals**

● **Draw Normal Vectors**

**Apply**

You will need to turn the model to see that the vectors are in the positive direction.

To quickly turn your model, select the following toolbar icon.

**Iso 1 View**

Also, it is helpful to change the model to the **Hidden Line** render style, using the following toolbar icon.

**Hidden Line**

Your model should look like the figure shown in Figure 14.5:

**Figure 14.5 - Directions of elements' normals**

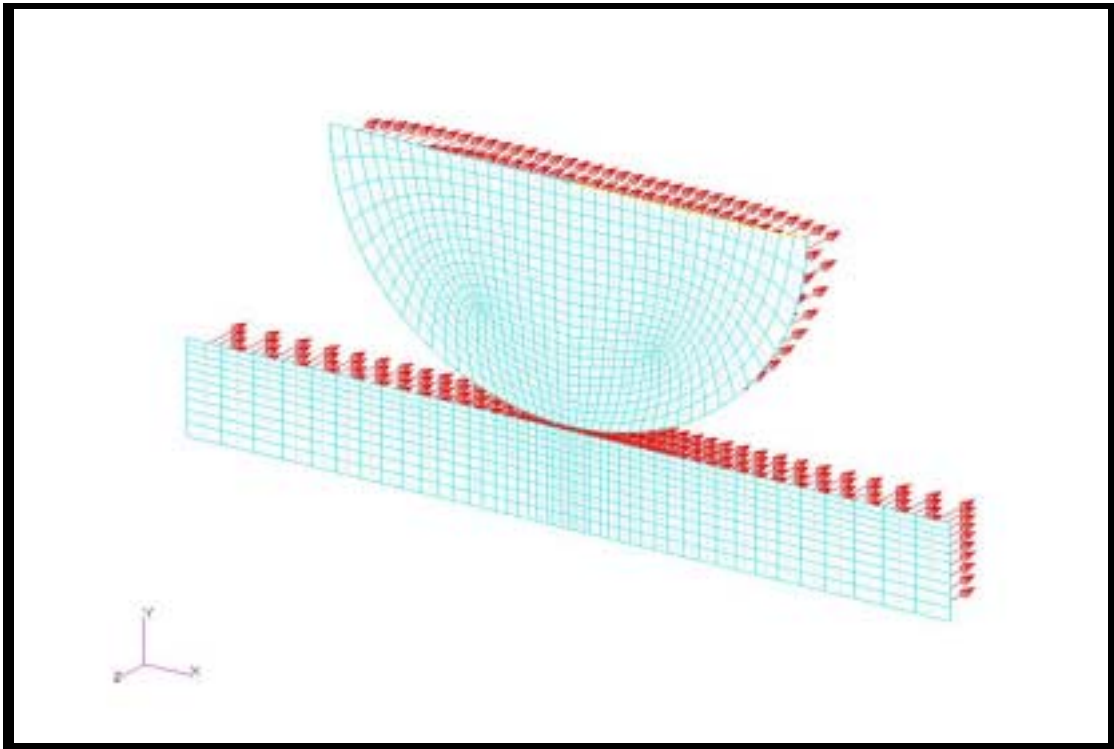

---

You will notice that the plate and cylinder elements are pointing in the **negative Z** direction. You will have to reverse them. First return to the original view by selecting the front view toolbar icon and change the model back to wireframe by picking the wireframe icon:



**Front View**



**Wire Frame**

Now first post only the elements on the cylinder.

### Group/Post ...

*Group:*

**cylinder**

**Apply**

**Cancel**

### ■ Elements

*Action:*

**Modify**

*Object:*

**Element**

*Test:*

**Reverse**

*Element List:*

Select all of the cylinder elements

**Apply**

Repeat the process for the plate by first posting the group **plate**, then reversing all the plate elements as well.

Reset the graphics display by selecting the Reset Graphics icon.



**Reset Graphics**

12. Create the steel and aluminum materials. The Steel has a Young's 30E6, and Poisson's Ratio 0.30. The Aluminum has a Young's 10E6, and Poisson's Ratio 0.33

### ■ Materials

*Action:*

**Create**

<i>Object:</i>	<input type="text" value="Isotropic"/>
<i>Method:</i>	<input type="text" value="Manual Input"/>
<i>Material Name:</i>	<input type="text" value="steel"/>
<input type="button" value="Input Properties..."/>	
<i>Constitutive Model:</i>	<input type="text" value="Elastic"/>
<i>Elastic Modulus:</i>	<input type="text" value="30E6"/>
<i>Poisson's Ratio:</i>	<input type="text" value="0.30"/>
<input type="button" value="OK"/>	
<input type="button" value="Apply"/>	

Repeat the above step for to create an aluminum material. Change the *Material Name* to be **aluminum**. Change the *Elastic Modulus* to be **10E6** and the *Poisson's Ratio* to be **0.33**.

13. Create a new group named **all**.

This group will contain all the geometries and the finite elements for the entire model in it.

<b>Group/Create...</b>	
<i>New Group Name:</i>	<input type="text" value="all"/>
<input checked="" type="checkbox"/> <b>Make Current</b>	
<input checked="" type="checkbox"/> <b>Unpost All Other Groups</b>	
<i>Group Contents:</i>	<input type="text" value="Add All Entities"/>
<input type="button" value="Apply"/>	
<input type="button" value="Cancel"/>	

14. Create the element properties **cylinder** and **plate**.

<input checked="" type="checkbox"/> <b>Properties</b>	
<i>Action:</i>	<input type="text" value="Create"/>
<i>Dimension:</i>	<input type="text" value="2D"/>
<i>Type:</i>	<input type="text" value="2D Solid"/>

<i>Property Set Name:</i>	<input type="text" value="cylinder"/>
<i>Options:</i>	<input type="text" value="Plain Strain"/>
	<input type="text" value="Standard Formulation"/>
<input type="button" value="Input Properties..."/>	
<i>Material Name:</i>	<input type="text" value="steel"/>
<i>Thickness:</i>	<input type="text" value="1.0"/>
<input type="button" value="OK"/>	
<i>Select Members:</i>	<input type="text" value="see Figure 14.6"/>
<input type="button" value="Add"/>	
<input type="button" value="Apply"/>	

Repeat the same process with a new *Property Set Name* of **plate**. The *Input Properties* are the same except the material will be **aluminum**. Enter **Surface 3** (shown in Figure 14.6) in the *Select Members* list box.

**Figure 14.6 - Elements to be assigned properties**

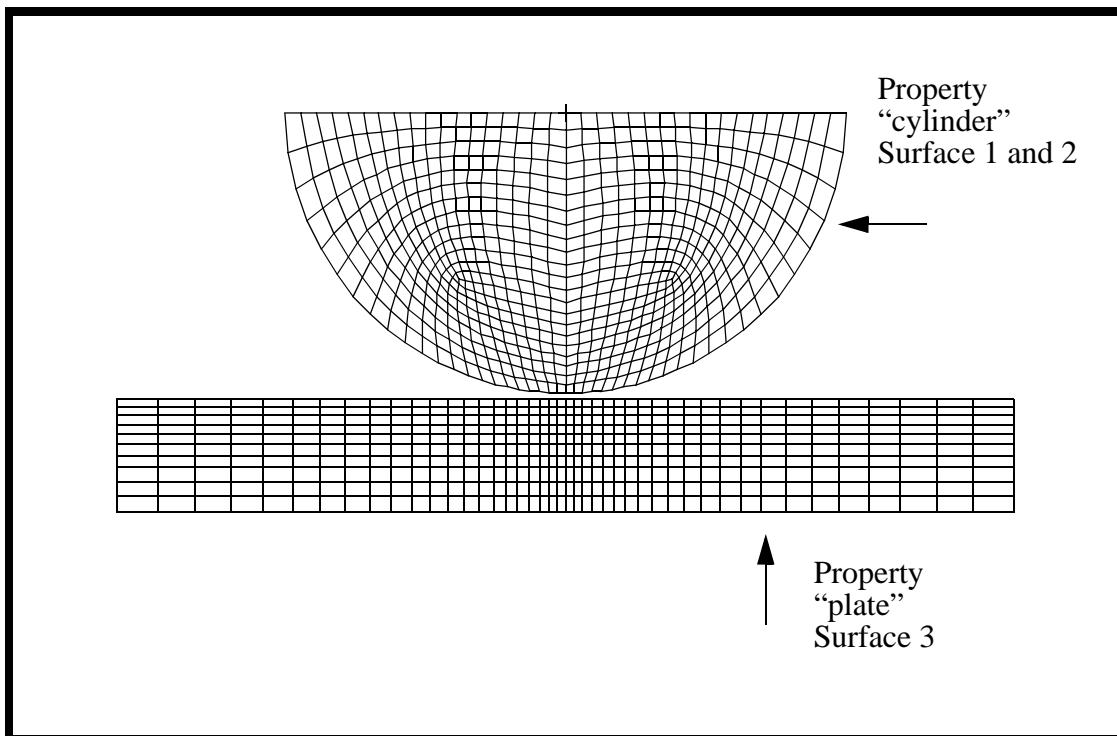

15. Fix the base in the X-direction.

■ **Loads/BCs**

Action:

Object:

Type:

New Set Name:

Translations  $\langle T1, T2, T3 \rangle$ :

Rotations  $\langle R1, R2, R3 \rangle$ :

Geometry Filter:  **FEM**

Select Nodes:

16. Fix the base in the Y direction.

Action:

Object:

Type:

New Set Name:

Translations  $\langle T1, T2, T3 \rangle$ :

Rotations  $\langle R1, R2, R3 \rangle$ :

Geometry Filter:

● Geometry

Select Geometric Entities:

see Figure 14.7

Click in the *Select Geometric Entities* databox and select the curve on the bottom edge of model as shown in Figure 14.7:

First, you will want to click on the curve icon:



Figure 14.7 - Fixed base of plate.

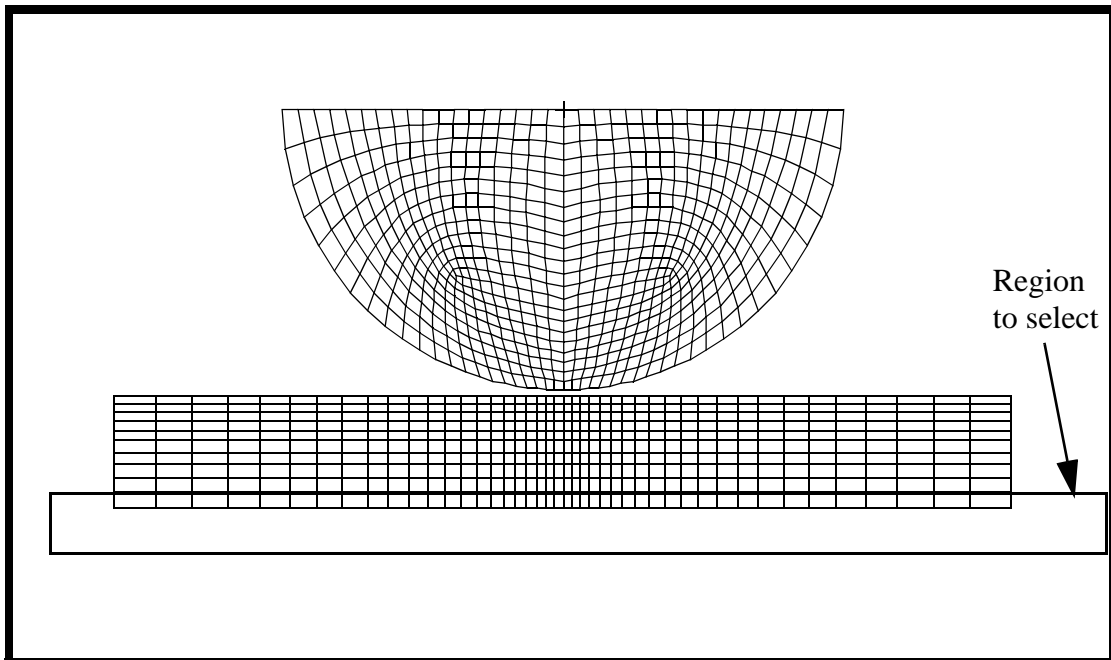

Add

OK

Apply

17. In this step, you are going to create a displacement set that will be used to close the gap between the cylinder and plate and insure contact. Apply a displacement in the Y direction along the top surface of -0.105. Note that

since the contact area between the cylinder and the base is small, it is assumed that the vertical displacements along the diameters of the steel ball are uniform.

<i>Action:</i>	<input type="text" value="Create"/>
<i>Object:</i>	<input type="text" value="Displacement"/>
<i>Type:</i>	<input type="text" value="Nodal"/>
<i>New Set Name:</i>	<input type="text" value="fixed_cyl_1"/>
<input type="button" value="Input Data..."/>	
<i>Translations &lt;T1,T2,T3&gt;:</i>	<input type="text" value="&lt; 0, , &gt;"/>
<i>Rotations &lt;R1,R2,R3&gt;:</i>	<input type="text" value="&lt; , , &gt;"/>
<input type="button" value="OK"/>	
<input type="button" value="Select Application Region..."/>	
<i>Geometry Filter:</i>	<input checked="" type="radio"/> <b>FEM</b>
<i>Select Nodes:</i>	<input type="text" value="see Figure 14.8 to select Node 326 327"/>

Click in the *Select Nodes* databox and select the two nodes shown in Figure 14.8:

**Figure 14.8 - Selected nodes to apply close\_gap to**

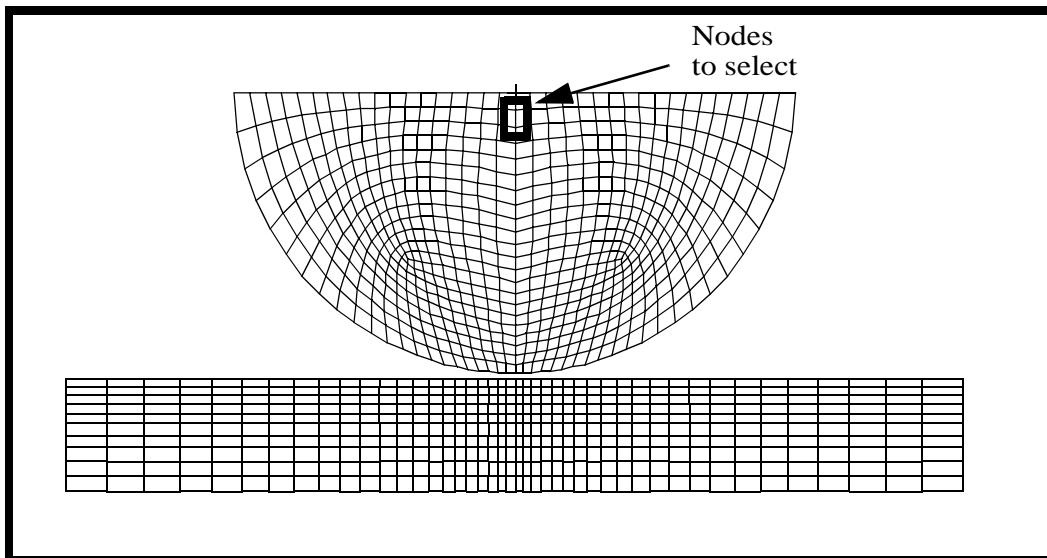

**Add**

**OK**

**Apply**

18. Create contact bodies for the cylinder and base plate.

<i>Action:</i>	<b>Create</b>
<i>Object:</i>	<b>Contact</b>
<i>Type:</i>	<b>Element Uniform</b>
<i>Option:</i>	<b>Deformable Body</b>
<i>Analysis Type:</i>	<b>Structural</b>
<i>New Set Name:</i>	<b>cylinder_contact</b>
<i>Target Element Type:</i>	<b>● 2D</b>
<b>Select Application Region...</b>	

**Figure 14.9 - Contact body definition**

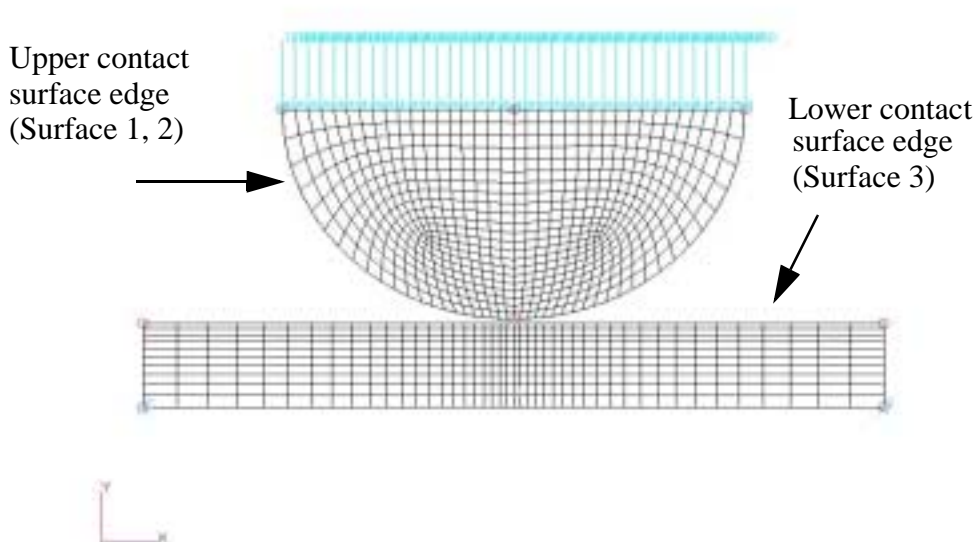

*Geometry Filter:*

**● Geometry**

*Select Surfaces:*

**select all surfaces on cylinder**

*Action:**Object:**Type:**Option:**Analysis Type:**New Set Name:**Geometry Filter:* **Geometry***Select Surfaces:*

19. The final Load and Boundary Condition will be the applied pressure at the top of the cylinder. We will simulate a load of 100,000 lb per unit depth across the entire cylinder. The applied edge pressure will be simply the load per unit depth divided by the diameter, or  $100,000/10.0 = 10,000$  psi pressure.

*Action:**Object:**Type:**New Set Name:**Target Element Type:**Edge Pressure:*

**Select Application Region...**

Geometry Filter:  FEM

Select 2D Elements or Edges:

Click on the element edge icon. Then,



**Edge of Element**

select the top edge of the model as shown in Figure 14.10:

**Figure 14.10 - Region to apply pressure to**

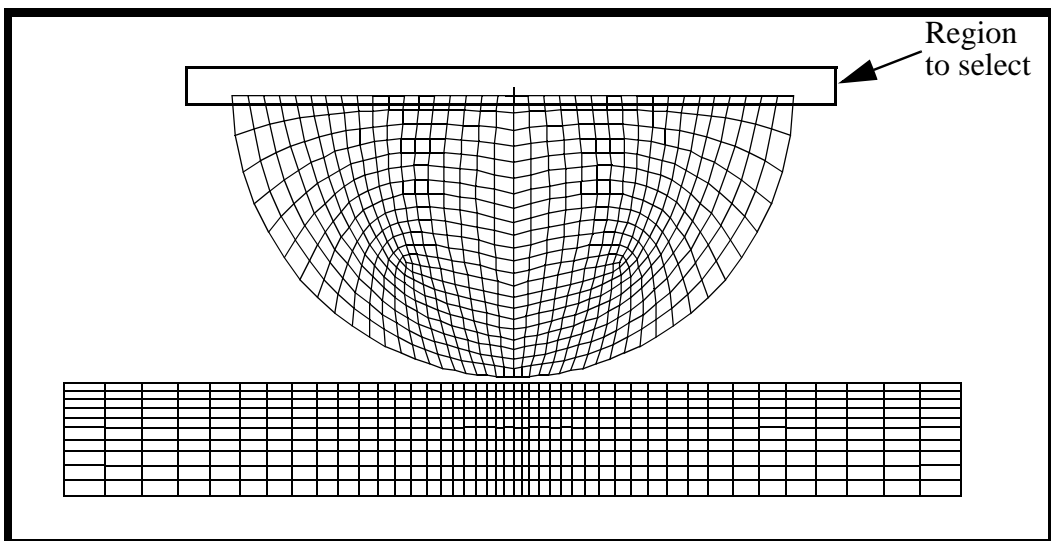

**Add**

**OK**

**Apply**

20. Now create the analysis step using the default analysis parameters and output requests.

**■ Analysis**

Action:

**Analyze**

Object:

**Entire Model**

Method:

**Full Run**

*Job Name:*

*Job Step Name:*

*Solution Type:*

Non-Positive Definite

21. Select the steps and submit the job for analysis. Make sure that the Default Static Step is not selected.

*Selected Job Steps:*

22. Monitor the analysis by monitoring the **.sts**, **.log**, or **.out** files. Also, the **Monitor** option is readily available.

*Action:*

*Object:*

After the job has finished, a successful completion will result with: Job ends with exit number: 3004. These files can be viewed during or after a job has completed. Once the job is finished, read the results.

■ **Analysis**

*Action:*

---

<i>Object:</i>	<input type="text" value="Result Entities"/>
<i>Method:</i>	<input type="text" value="Attach"/>
<input type="button" value="Select Results File..."/>	
<i>Selected Results File:</i>	<input type="text" value="hertz.t16"/>
<input type="button" value="OK"/>	
<input type="button" value="Apply"/>	

When PATRAN opens again the results will be incorporated into the database.

23. Post the group **fem**.

<b>Group/Post...</b>	
<i>Select Groups to Post:</i>	<input type="text" value="fem"/>
<input type="button" value="Apply"/>	
<input type="button" value="Cancel"/>	

24. Make fringe plots of Von Mises,  $\sigma_{yy}$  and  $\sigma_{xy}$ .

<b>■ Results</b>	
<i>Action:</i>	<input type="text" value="Create"/>
<i>Object:</i>	<input type="text" value="Quick Plot"/>
<i>Select Results Cases:</i>	<input type="text" value="select the last result case"/>
<i>Select Fringe Result:</i>	<input type="text" value="Stress, Global System"/>
<i>Quantity:</i>	<input type="text" value="Von Mises"/>
<input type="button" value="Apply"/>	

Your model should appear as shown in Figure 14.11:

Figure 14.11 - Stress plot of results

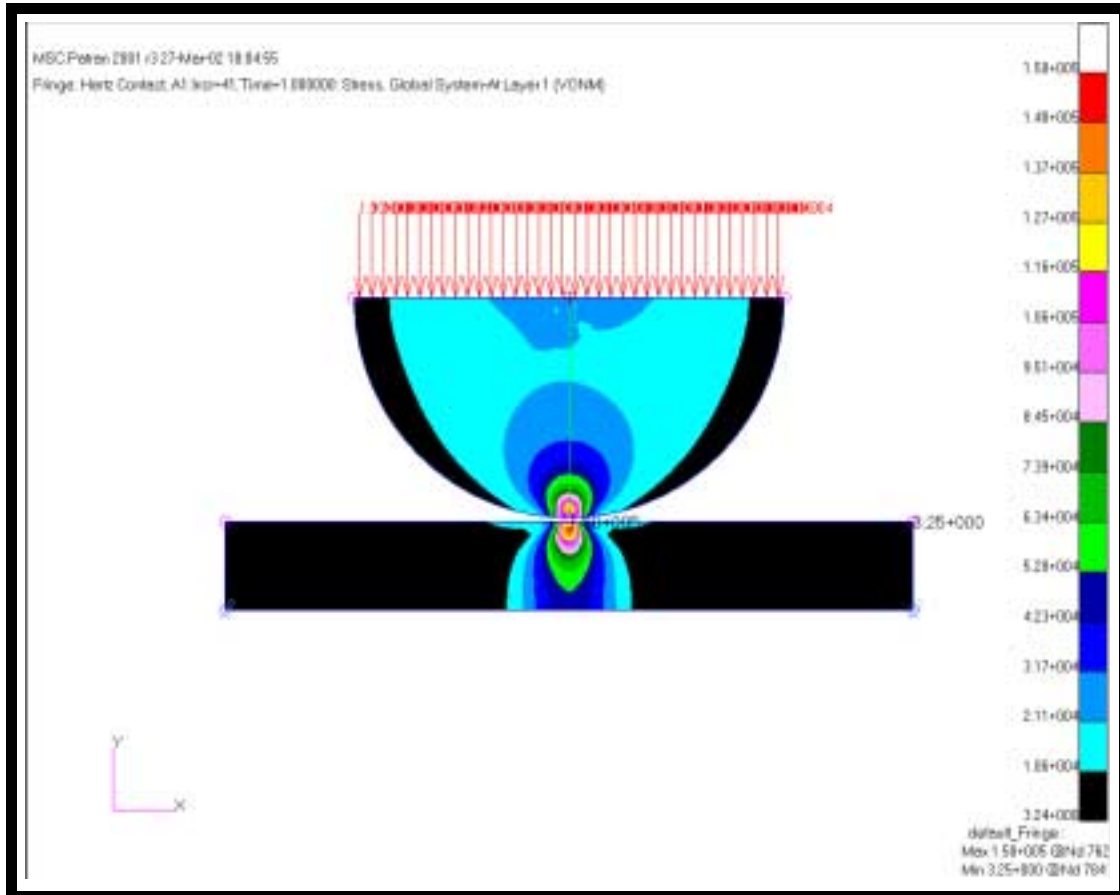

Clear the viewport using the following icon in the top menu bar.



**Reset Graphics**

Now create the  $\sigma_{yy}$  plot.

Quantity:

**Y-Component**

**Apply**

Clear the viewport using the following icon in the top menu bar.



**Reset Graphics**

---

Finally, use the above procedure to create a  $\sigma_{xy}$  plot to see the shear stresses. Make sure clean up the viewport using the Reset Graphics Icon.

25. Make a deformed plot with von Mises stresses plotted.

Before we make the deformed plot, we need to change the scale factor of the result to 1.0 so that the plot will represent the actual deformation. In the Results form select the **Deform Attributes** icon.



**Show Undeformed**

Go back to the **Selects Results** form



*Select Result Cases:*

select last load case

*Select Fringe Result:*

**Stress, Global System**

*Result Type:*

**von Mises**

*Select Deformation Result:*

**Displacement, Translation**

**Apply**

Notice that the two bodies are in contact, and that there is even a slight deformation of both the plate and cylinder. To get a better view, zoom in on the contact zone by using the **View Corners** icon.



**View Corners**

Your model should now appear as shown in Figure 14.12:

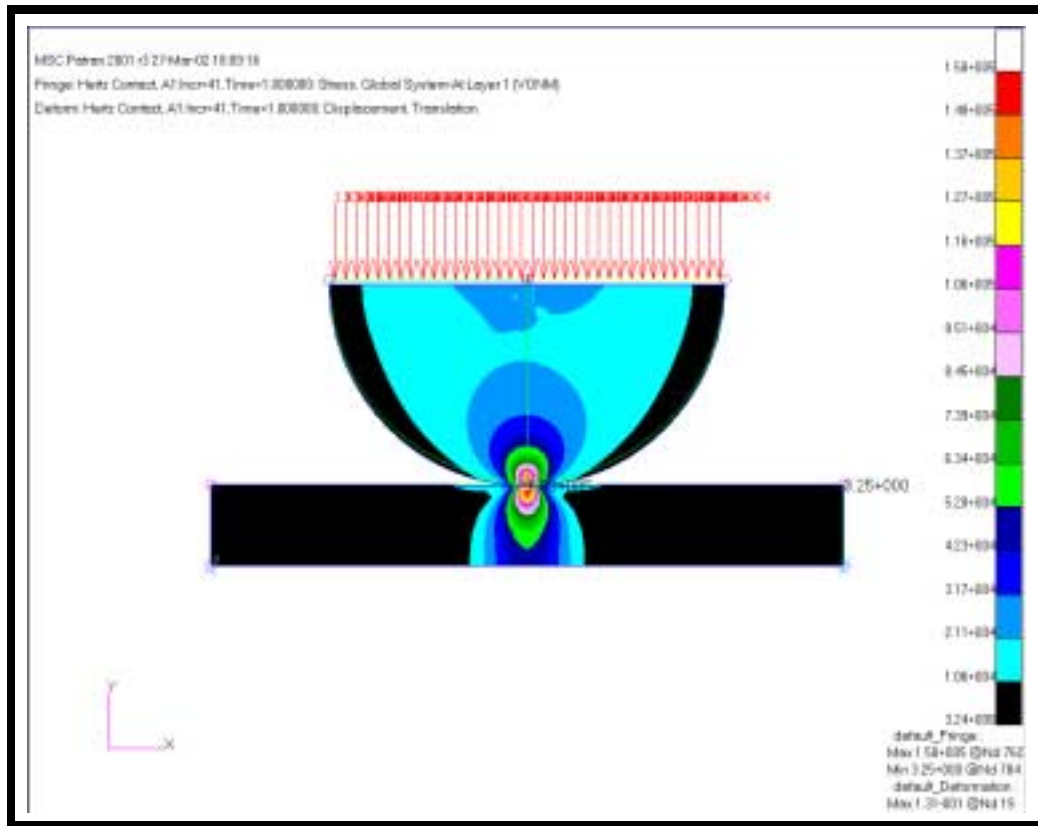
**Figure 14.12 - Zoomed in plot of stress and contact verification****26. Theoretical Comparison**

From the 6th Edition of Roarks's Formulas for Stress and Strain (by Warren C. Young, 1989, pg 651) we can derive the contact patch,  $b$ , and the maximum compressive stress

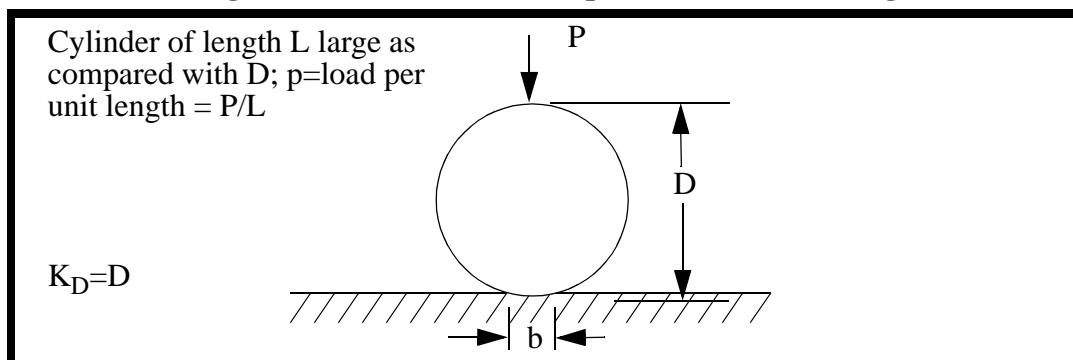
**Figure 14.13 - Theoretical representation of loading**

---

The contact width for a full model is given by

$$b = 1.60 \sqrt{p K_D C_E}$$

where

$$C_E = \frac{1 - \nu^2}{E_1} + \frac{1 - \nu^2}{E_2}$$

and the maximum stress is given by

$$\text{Max}\sigma_c = 0.798 \sqrt{\frac{P}{K_D C_E}}$$

For our solution,  $C_E$ , is equal to

$$C_E = \frac{1 - (0.3)^2}{30 \times 10^6} + \frac{1 - (0.33)^2}{10 \times 10^6} = 1.1944 \times 10^{-7}$$

The contact area for a half model is equal to

$$\frac{b}{2} = 0.80 \sqrt{100,000(10)1.1944 \times 10^{-7}} = 0.276$$

The Maximum compressive stress is given by

$$\text{Max}\sigma_c = 0.798 \sqrt{\frac{100,000}{(10)1.1944 \times 10^{-7}}} = 230,900$$

We can compare the maximum Y compressive stress values to a summary listing of the maximum stresses output for the cylinder and base plate from text report.

27. Generate a text report of the Y compressive stresses..

*Action:*

**Create**

*Object:*

**Report**

*Method:*

**Preview**

*Select Results Cases:*

**select last increment,  
Time = 2.0**

*Select Report Result:***Stress, Global System**Select the **Display Attributes** icon:**Sorting Options ...***Sort Order:*● **Ascending***Sort Data By:***Y Component****OK****Apply**

The results will be printed to the output window. If you scroll to the top of the list output by the Text Reporter, you will see the most severely loaded element. Use that information to fill out the table below.

**Table 1: Maximum Compressive Stress**

	Theoretical	AFEA	% Diff
<b>Max <math>\sigma_c</math></b>	<b>230,900</b>		

Close the database and quit PATRAN.

This concludes this exercise.

